

Electric Switch Mechanisms

Installation and Operating Manual



Series
B, C, D, F,
O, Q, S, U, W,
and X
with
Aluminum,
Carbon Steel,
or
Cast Iron
Housings

Read this Manual Before Installing

This manual provides information on Electric Switch Mechanisms. It is important that all instructions are read carefully and followed in sequence. Detailed instructions are included in the Installation section of this manual.

Conventions Used in this Manual

Certain conventions are used in this manual to convey specific types of information. General technical material, support data, and safety information are presented in narrative form. The following styles are used for notes, cautions, and warnings.

NOTES

Notes contain information that augments or clarifies an operating step. Notes do not normally contain actions. They follow the procedural steps to which they refer.

Cautions

Cautions alert the technician to special conditions that could injure personnel, damage equipment, or reduce a component's mechanical integrity. Cautions are also used to alert the technician to unsafe practices or the need for special protective equipment or specific materials. In this manual, a caution indicates a potentially hazardous situation which, if not avoided, may result in minor or moderate injury.

WARNINGS

Warnings identify potentially dangerous situations or serious hazards. In this manual, a warning indicates an imminently hazardous situation which, if not avoided, could result in serious injury or death.

WARNING! Explosion hazard. Do not connect or disconnect equipment unless power has been switched off or the area is known to be non-hazardous.

Low Voltage Directive

For use in Installation Category II, Pollution Degree 2. If equipment is used in a manner not specified by manufacturer, protection provided by equipment may be impaired.

Notice of Copyright and Limitations

Magnetrol & Magnetrol logotype are registered trademarks of Magnetrol International. Copyright © 2011 Magnetrol International. All rights reserved.

Performance specifications are effective with date of issue and are subject to change without notice.

Magnetrol reserves the right to make changes to the products described in this manual at any time without notice. Magnetrol makes no warranty with respect to the accuracy of the information in this manual.

Warranty

All Magnetrol mechanical level and flow controls are warranted free of defects in materials or workmanship for five full years from the date of original factory shipment.

If returned within the warranty period; and, upon factory inspection of the control, the cause of the claim is determined to be covered under the warranty; then, Magnetrol will repair or replace the control at no cost to the purchaser (or owner) other than transportation.

Magnetrol shall not be liable for misapplication, labor claims, direct or consequential damage or expense arising from the installation or use of equipment. There are no other warranties expressed or implied, except special written warranties covering some Magnetrol products.

Quality Assurance

The quality assurance system in place at Magnetrol guarantees the highest level of quality throughout the company. Magnetrol is committed to providing full customer satisfaction both in quality products and quality service.

The Magnetrol quality assurance system is registered to ISO 9001 affirming its commitment to known international quality standards providing the strongest assurance of product/service quality available.





Electric Switch Mechanisms

Table of Contents

1.0 Reference Information	4	4.0 Preventative Maintenance	13
1.1 Principle of Operation	4	4.1 Inspect Switch Mechanisms.....	13
1.2 Operating Cycle.....	4	5.0 Switch Specifications	14
1.3 Description	5	6.0 Replacement Switch Mechanisms	15
1.3.1 Dry contact switches B, C, D, O, Q, S and U ...	5	6.0.1 Magnet strength	15
1.3.2 Hermetically sealed switches F, W and X.....	5	6.1 Yellow Dot Magnet Replacement Mechanisms.....	15
2.0 Installation	6	6.1.1 Series B, C, D, F, O, Q, S, U, W and X.....	15
2.1 Replacing Switch Mechanism.....	6	6.2 Red Dot Magnet Replacement Mechanisms.....	16
2.2 Replacing Dry Contact Switches	7	6.2.1 Series B, C, F, U, W and X	16
2.2.1 Series B, C, D, F, O, Q, S, U, W and X.....	7	7.0 Switch Housing Replacement Assemblies	17
2.3 Vibration Service Adjustment	8	7.0.1 Aluminum housings	17
3.0 Wiring	9	7.0.2 Cast iron housings.....	18
3.1 SPDT Terminal Connections	9	7.0.3 Carbon steel housings.....	18
3.1.1 Single float with one switch or		7.1 Replacement Housing Kits.....	19
single stage displacer	9	7.1.1 Referred by eighth, ninth and tenth digit	19
3.1.2 Single float with two switches or		7.1.2 Referred by description	19
dual stage displacer.....	9	7.1.3 ATEX.....	19
3.1.3 Single float with three switches or		7.2 Replacement Gaskets and Hardware	20
three stage displacer.....	10	8.0 Manual Reset Option	20
3.2 DPDT Terminal Connections.....	11	8.1 Parts Breakdown and Identification.....	20
3.2.1 Single float with one switch or		8.2 Field Installation Instructions.....	21
single stage displacer.....	11	9.0 Switch and Housing Model Codes	22
3.2.2 Single float with two switches or		9.1 Type 4, 4X, 7, 9 and Group B Enclosure Codes	22
dual stage displacer.....	11	9.2 ATEX Enclosure Codes.....	31
3.2.3 Three stage displacer	12		

1.0 Reference Information

1.1 Principle of Operation

Figures 1 & 2 illustrate the simple, reliable operating principle of a float level switch. Switching action is obtained through the use of a magnetic sleeve (4) and a float (3), displacer or flow sensing element and a switching mechanism (2). These two basic component assemblies are separated by a non-magnetic, pressure tight enclosing tube (5). The switch (2) and magnet (1) are assembled to a mechanism with a swinging arm which operates on precision stainless steel pivots.

1.2 Operating Cycle

As level of a liquid in a vessel rises (Figure 1), the float rides on the liquid surface moving the magnetic sleeve upward in the enclosing tube and into the field of the switch mechanism magnet. As a result, the magnet is drawn in tightly to the enclosing tube moving the switch adjusting screw and allowing the activating arm of the snap switch to move, making or breaking the electrical circuit. As the liquid level recedes (Figure 2), the float and magnetic sleeve moves downward until the switch magnet releases and is drawn outward, away from the enclosing tube by a tension spring. This in turn allows the activating arm of the snap switch to move, thus reversing switch action.

Switch mechanisms may include a single switch or multiple switches, depending on operational requirements and switching action desired.

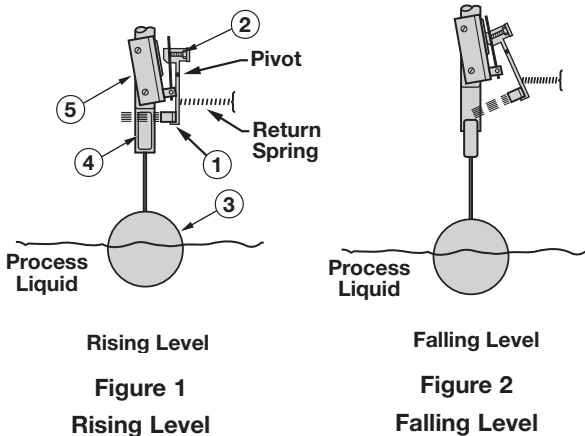

1.3 Description

Magnetrol level controls are available with a range of different switch mechanisms—each designed for specific service conditions. A brief description of the individual switch mechanisms and their applications are given below.

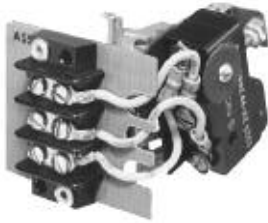

Figure 3
Series B, C, D, O and Q Dry Contact Switches



Figure 4
Series S Snap Switch



Figure 5
Series F Hermetically Sealed Switch

1.3.1 Dry Contact Switches B, C, D, O, Q, S and U

- **Series B** switches are general purpose with a maximum liquid temperature rating of +250° F (+121° C), see Figure 3.
- **Series C** switches are general purpose with a maximum liquid temperature rating of +450° F (+232° C), see Figure 3.
- **Series D** switches are designed for DC current applications with a maximum liquid temperature rating of +250° F (+121° C), see Figure 3.
- **Series O** switches are general purpose with a maximum liquid temperature rating of +300° F (+149° C), used only in model C10 and C15 units, see Figure 3.
- **Series Q** switches are general purpose with a maximum liquid temperature rating of +250° F (+121° C), used only in model C10 and C15 units, see Figure 3.
- **Series S** switches are general purpose with a maximum liquid temperature rating of +550° F (+288° C), or designed for DC current applications with a maximum liquid temperature of +250° F (+121° C), used only in model B40 units, see Figure 4.
- **Series U** switches have gold alloy contacts and are suitable for applications with a maximum liquid temperature of +250° F (+121° C).

1.3.2 Hermetically Sealed Switches F, W and X

Hermetically sealed switches are for use in special applications where hermetically sealed contacts are required.

- **Series F** switches are well suited for use in process temperatures up to +750° F (+399° C), see Figure 5.
- **Series W** switches are suitable for applications with a maximum liquid temperature of +450° F (+232° C).
- **Series X** switches have gold-plated contacts and are suitable for applications with a maximum liquid temperature of +450° F (+232° C).

NOTE: See bulletin 42-694 for series HS & H1 hermetically sealed switches.

2.0 Installation

2.1 Replacing Switch Mechanism

Caution: Before attempting to remove a switch mechanism, be certain to pull disconnect switch or otherwise assure that electrical circuit through control is de-energized.

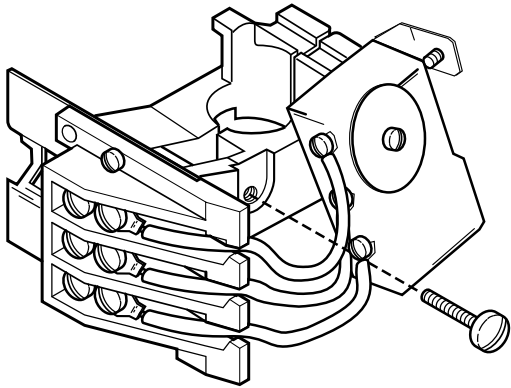

Figure 6
Mounting Screw

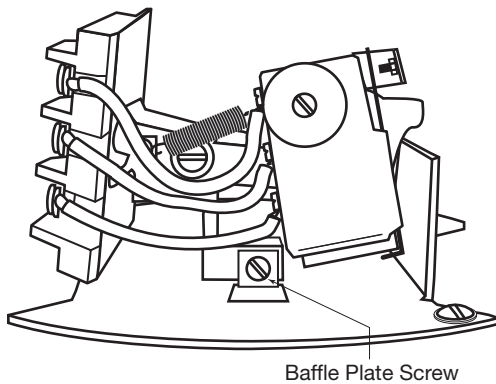

Figure 7
Baffle Plate Screw

1. Disconnect wiring from supply side of terminal block on switch mechanism. Note and record lead wire terminal locations.
2. Loosen screw in split mounting clamp until mechanism slides freely on enclosing tube, refer to Figure 6.
3. Remove small round head screw securing lower switch mechanism to baffle plate, refer to Figure 7.
4. Slide switch mechanism off of enclosing tube. If mechanism is to be reused, ensure that it is placed on a clean surface, free of metallic particles that may be attracted to the switch magnet.
5. Loosen mounting screw so that switch frame will fit over e-tube. Install switch mechanism by sliding it over the enclosing tube. Slide mechanism down until the bottom of the frame and terminal block are resting on the baffle plate. The baffle plate should be resting on the hub of the housing base.
6. Install and tighten baffle plate screw so that the switch mechanism may not be separated from the baffle plate. Tighten the mechanism mounting screw so that the mechanism is firmly clamped to the enclosing tube.
7. Swing magnet assembly in and out by hand, checking carefully for any signs of binding.
8. Reattached supply-side wiring to the terminal block and check switch function by varying liquid level in the vessel.

2.2 Replacing Dry Contact Switches

2.2.1 Series B, C, D, F, O, Q, S, U, W and X

1. Disconnect control from power supply.
2. Disconnect switch leads from terminal block. Note and record terminal connections of switch to be replaced.
3. Remove two mounting screws holding existing switch, refer to Figure 8.
4. Remove existing switch and install replacement switch in the same position, tightening mounting screws securely.

NOTE: For proper operation of the replacement switch, it must actuate in the middle portion of the pivoted magnet's swing.

5. Check switch action and adjust as follows:
 - a. Slowly rotate the pivoted magnet by hand, back and forth through its angle of swing, listening closely for the actuating click of the switch in each direction.
 - b. Check to see if there is equal overtravel of magnet in its swing after the switch click in either direction.
 - c. If switch actuation is not correct, change adjustment of actuating screw using a $\frac{1}{16}$ " hexagon key wrench, refer to Figure 8.

NOTE: If a single switch is being replaced on a DPDT mechanism, lever of second switch must be depressed and held to allow for the audible adjustment of new switch, as described above.

- d. With new switch in adjustment, release lever of second switch and perform fine-tuning of both switches to provide simultaneous actuation (clicks).
6. Reconnect power supply and test switch action by varying liquid level in the vessel or by "gently blowing down" float chamber.

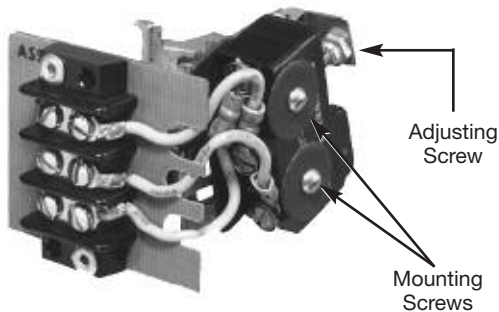

Figure 8
Dry Contact Switch Mechanism

2.3 Vibration Service Adjustment

Level controls are frequently used in applications where vibration is encountered, such as on scrubbers or compressors. Switch mechanisms may require repositioning to prevent unwanted magnet movement. This position is usually best at right angles to the direction of vibration. The direction of vibration may be determined by the arrangement of connections to the vessel or the vessels mounting method. Accordingly, the vibration will tend to be in one direction only.

Upon determining the vibration direction, switch mechanism(s) may be rotated from an incorrect position (as shown in Figure 9, illustration is shown as looking at a control from above), to a correct position as follows:

Caution: Before attempting to remove a switch mechanism, be certain to pull disconnect switch or otherwise assure that electrical circuit through control is de-energized.

1. Disconnect control from power supply.
2. Loosen screw in split mounting clamp until mechanism turns freely on enclosing tube, refer to Figure 6 on page 6.
3. Rotate entire mechanism and bottom baffle plate together to the correct position.

Caution: Be certain power supply wires retain some slack at new position. Do not pull wires taut.

NOTE: Amount of rotation required will vary with each installation and may not be as much as shown in illustration.

4. Check action of switch magnet at new position. When magnet vibrates from side to side, instead of front to back, correct position has been attained.
5. Tighten clamp screw on switch mechanism.
6. Reconnect power supply, and test switch action under operating conditions.

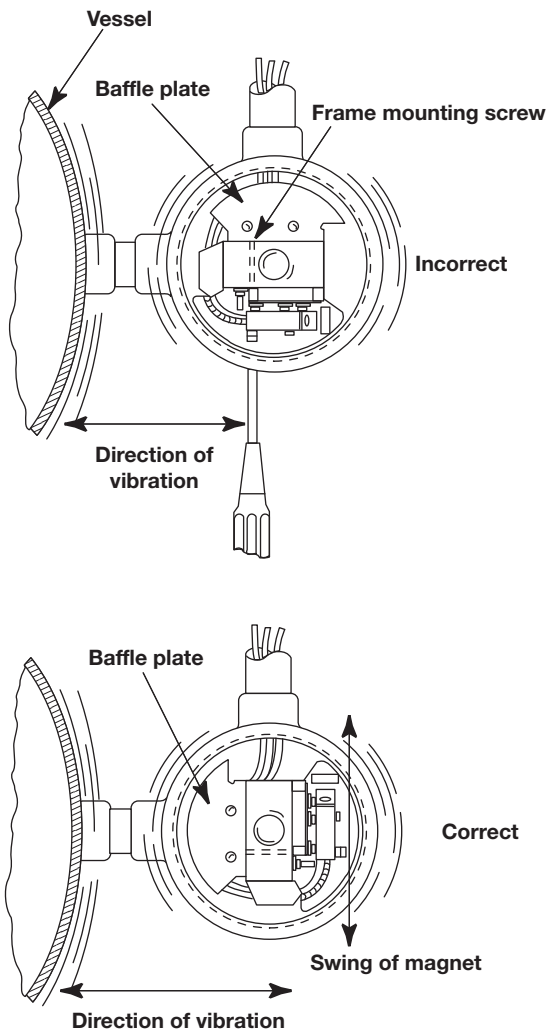

Figure 9
Rotation of Switch
Mechanism in Vibration

3.0 Wiring

Circuits shown are for direct-acting level switches and are reversed in side mounting float-in-tank models, which utilize a reversing float pivot.

NOTE: See bulletin 42-694 for wiring diagrams for “HS” Series hermetically sealed switches.

3.1 SPDT Terminal Connections

3.1.1 Single float with one switch or single stage displacer

1. Rising level closes contacts 5 & 6, see Figure 10.
2. Falling level closes contacts 4 & 5.
3. Wiring Diagram is reversed (high level actuation becomes low level actuation, etc.) when this switch mechanism is used on side mounted float switches employing a reversing pivot (Models B40, T52, T62, T63, etc.).

3.1.2 Single float with two switches or dual stage displacer

1. Rising level closes contacts 5 & 6 and 2 & 3, see Figure 11.
2. Falling level closes contacts 4 & 5 and 1 & 2.
3. Wiring diagram is reversed (high level actuation becomes low level actuation, etc.) when this switch mechanism is used on side mounted float switches employing a reversing pivot (Models B40, T52, T62, T63, etc.).
4. On units with tandem floats, the top float operates the bottom mechanism while the bottom float actuates the top mechanism.

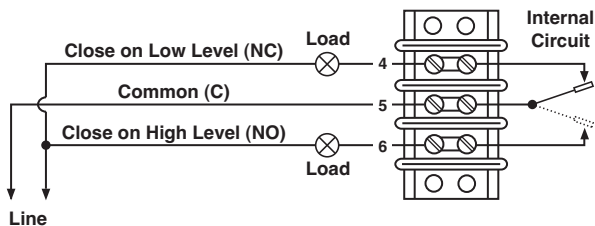

Figure 10
Single Float with One Switch
or Single Stage Displacer

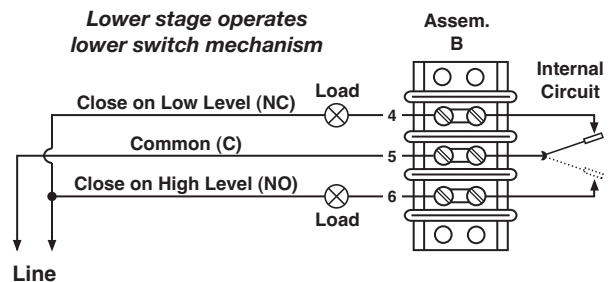
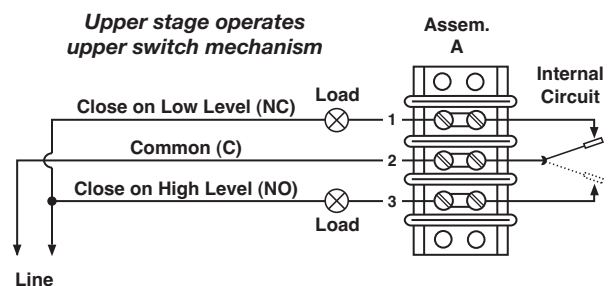

Figure 11
Single Float with Two Switches
or Dual Stage Displacer

3.1.3 Single float with three switches or three stage displacer:

1. Rising level closes contacts 5 & 6 and 2 & 3, see Figure 12.
2. Falling level closes contacts 4 & 5 and 1 & 2.
3. Unit is shipped with switches positioned for proper function. Do not change switch spacing.

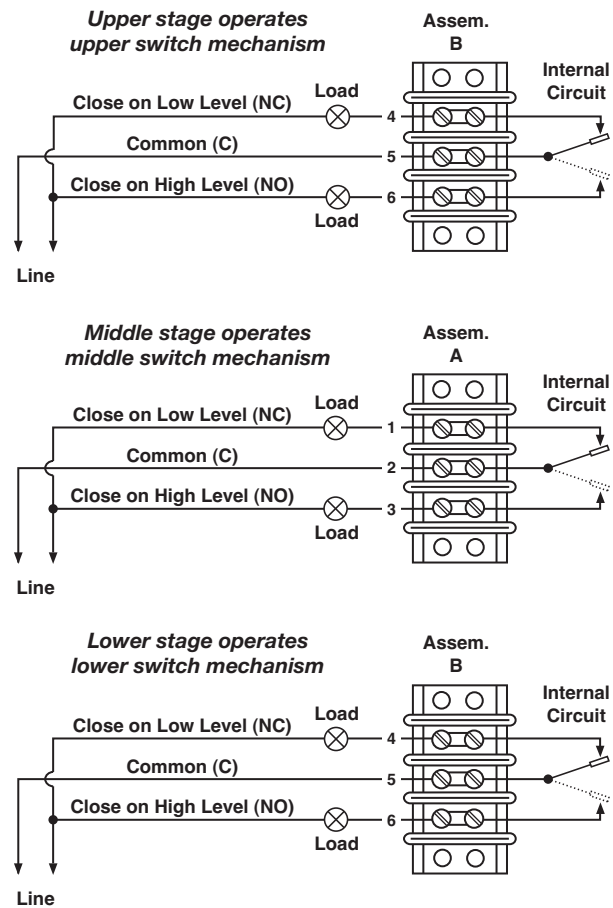

Figure 12
Single Float with Three Switches
or Three Stage Displacer

3.2 DPDT Terminal Connections

3.2.1 Single float with one switch or single stage displacer

1. Rising level closes contacts 5 & 6 and 2 & 3, see Figure 13.
2. Falling level closes contacts 4 & 5 and 1 & 2.
3. Double pole action is obtained by simultaneous operation of the right and left side single pole double throw switches.
4. Wiring diagram is reversed (close on high becomes close on low, etc.) when this switch mechanism is used on side mounted float switches employing a reversing pivot. (Models B40, T52, T62, T63, etc.)

3.2.2 Single float with two switches or dual stage displacer

1. Rising level closes contacts 5 & 6 and 2 & 3, see Figure 14.
2. Falling level closes contacts 4 & 5 and 1 & 2.
3. Double pole action is obtained by simultaneous operation of the right and left side single pole switches.
4. Wiring diagram is reversed (close on high becomes close on low, etc.) when this switch mechanism is used on side mounted float switches employing a reversing pivot. (Models B40, T52, T62, T63, etc.)
5. On units with tandem floats, the top float operates the bottom mechanism while the bottom float actuates the top mechanism.

Lower stage operates lower switch mechanism

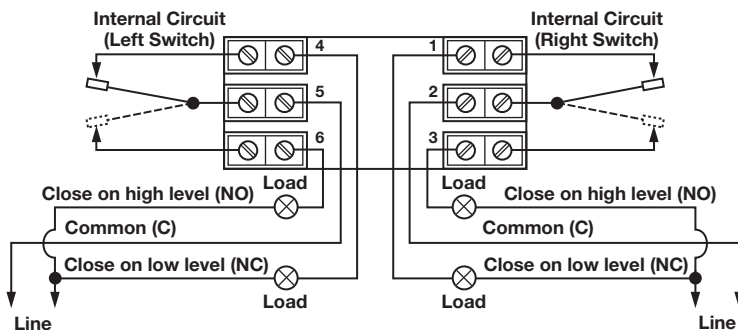

Upper stage operates upper switch mechanism

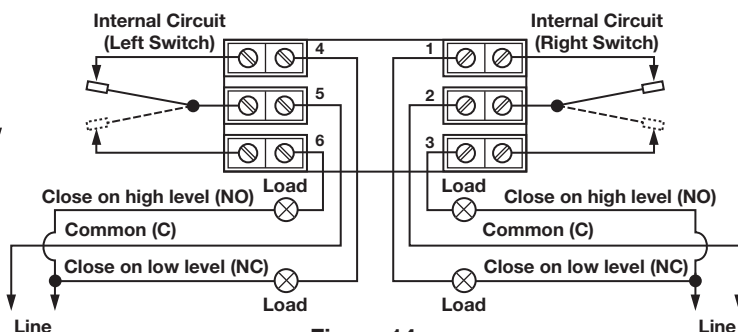

Figure 14
Single Float with Two Switches or Dual Stage Displacer

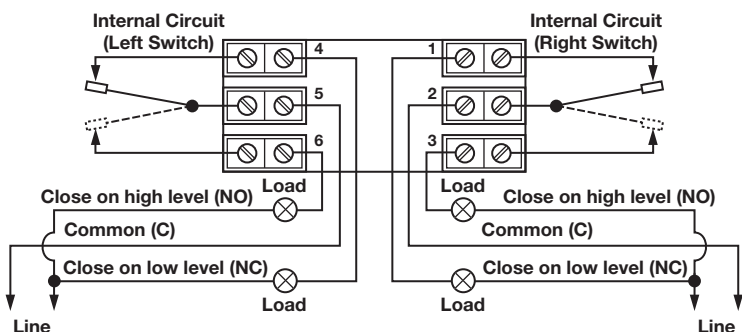

Figure 13
Single Float with One Switch
or Single Stage Displacer

3.2.3 Three Stage Displacer

1. Rising level closes contacts 5 & 6 and 2 & 3, see Figure 15.
2. Falling level closes contacts 4 & 5 and 1 & 2.
3. Double pole action is obtained by simultaneous operation of the right and left side single pole switches.

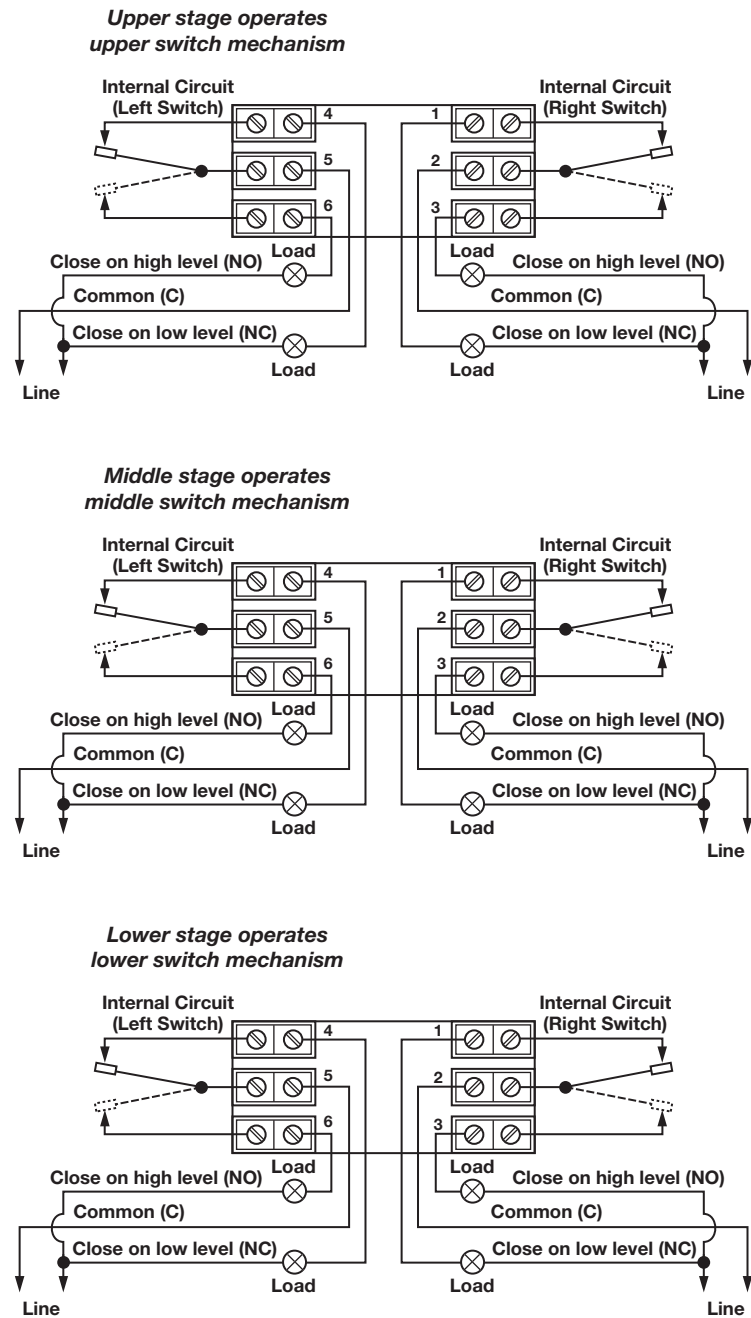

Figure 15
Three Stage Displacer

4.0 Preventative Maintenance

Inspect switch mechanisms, terminals and connections regularly. Proof test interval to be determined by application requirements (required reliability, operating conditions, site requirements, etc.).

4.1 Inspect Switch Mechanisms, Terminals and Connections

1. Dry contact switches should be inspected for excessive wear on actuating lever or misalignment of adjustment screw at point of contact between screw and lever. Such wear can cause false switch actuating levels.
2. DO NOT operate your control with defective or mal-adjusted switch mechanisms.
3. Level controls may sometimes be exposed to excessive heat or moisture. Under such conditions, insulation on electrical wiring may become brittle, eventually breaking or peeling away. The resulting “bare” wires can cause short circuits.

NOTE: Check wiring carefully and replace at the first sign of brittle insulation.

4. Vibration may sometimes cause terminal screws to loosen. Check all terminal connections to be certain that screws are tight.

NOTE: Spare switches should be kept on hand at all times.

5.0 Switch Specifications

SWITCH SERIES	SWITCH TYPE	PROCESS TEMP. RANGE ^① ° F (° C)	LOAD	RATING					
				Volts AC			Volts DC		
				120	240	480	24	120	240
B	Snap	-40 to +250 (-40 to +121)	Non-Inductive Amp Inductive Amp Horsepower	15.00 15.00 ¼	15.00 15.00 ¼	15.00 15.00 —	6.00 5.00 —	0.50 0.05 —	0.25 0.03 —
C	Snap	-40 to +450 (-40 to +232)	Non-Inductive Amp Inductive Amp Horsepower	15.00 15.00 ⅓	15.00 15.00 ¼	15.00 15.00 —	10.00 5.00 —	1.00 0.50 —	0.50 — —
D	Snap	-40 to +250 (-40 to +121)	Non-Inductive Amp Inductive Amp Horsepower	10.00 3.80 ⅓	— — —	— — —	10.00 — —	10.00 2.20 ⅓	1.50 min. — — 3.00 max.
F (followed by letter)	Hermetic	-50 to +750 (-46 to +399)	Resistive Amp Inductive Amp	2.50 2.50	— —	— —	4.00 ② 2.00 ②	0.30 0.10	— —
F (followed by number)	Hermetic	-50 to +250 (-46 to +121)	Resistive Amp Inductive Amp	1.00 1.00	— —	— —	15.00 ② 10.00 ②	— —	— —
O	Snap	-40 to +450 (-40 to +232)	Non-Inductive Amp Inductive Amp Horsepower	15.00 15.00 ⅓	15.00 15.00 ¼	15.00 15.00 —	— — —	1.00 — —	0.50 — —
Q	Snap	-40 to +250 (-40 to +121)	Non-Inductive Amp Inductive Amp Horsepower	15.00 15.00 ⅓	15.00 15.00 ¼	15.00 15.00 —	6.00 5.00 —	0.50 0.05 —	0.25 0.30 —
SA SD SK SN	Snap	-40 to +550 (-40 to +288)	Non-Inductive Amp Inductive Amp Horsepower	15.00 15.00 ⅓	15.00 15.00 ¼	15.00 15.00 —	— — —	1.00 0.50 —	0.50 — —
SB SE SL SO	Snap	-40 to +250 (-40 to +121)	Non-Inductive Amp Inductive Amp Horsepower	10.00 3.80 ⅓	— — —	— — —	10.00 — —	10.00 2.20 ⅓	1.50 min. — — 3.00 max.
(X) B (x=gold contacts)	Snap Gold Contacts	-40 to +250 (-40 to +121)	Non-inductive Inductive	1.00 1.00	— —	— —	— —	— —	— —
(X) F (x=gold contacts)	Hermetic Snap Gold Contacts	-50 to +750 (-46 to +399)	Non-inductive Inductive	— —	— —	— —	1.00 0.25	— —	— —
(X) HS (x=gold contacts)	Hermetic Snap Gold Contacts	-50 to +550 (-46 to +288) ③	Non-inductive Inductive	1.00 —	— —	— —	2.00 1.00	— —	— —
U	Snap Gold Contacts	-40 to +250 (-40 to +121)	Non-inductive Amp Inductive Amp Horsepower	1.00 — —	— — —	— — —	— — —	1.00 1.00 —	— — —
W	Hermetic Snap	-50 to +450 (-46 to +232)	Non-inductive Amp Inductive Amp Horsepower	1.00 — —	1.00 0.80 —	— — —	3.00 ② — —	0.50 — —	— — —
X	Hermetic Snap Gold Contacts	-50 to +450 (-46 to +232)	Non-inductive Amp Inductive Amp Horsepower	0.50 0.15 —	0.50 — —	— — —	0.50 — —	0.50 — —	0.50 — —

① Process temperatures based on +100° F (+38° C) ambient temperature.

② 28 VDC

③ On steam applications, temperature down-rated to +400° F (+204° C) at +100° F (+38° C) ambient.

6.0 Replacement Switch Mechanisms

6.0.1 Magnet strength

Switch mechanisms are provided with different strength magnets as determined by the characteristics of the level switch. A red, red/yellow or yellow dot is visible on each magnet. When ordering replacement switch mechanisms, be certain to determine the color dot on the magnet. For these types of switches, the tenth digit of the model number identifies the magnet used on the control. The correct magnet dot color may be chosen by finding the tenth digit of your model number at the top of the chart. Any model numbers preceded with an “X” are specially modified controls. Contact the factory for replacement part numbers.

6.1 Yellow Dot Magnet Replacement Mechanisms

6.1.1 Series B, C, D, F, O, Q, S, U, W & X – Yellow

Switch Series	Contacts	Quantity	8th & 9th Digit	10th Digit			Switch Only
				E, F, Y, M, W, Q, B, S, K			
				Bottom Mech	Middle Mech	Top Mech	
B	SPDT	1	BA, BK	089-7401-104	N/A	N/A	089-7101-020
		2	BB, BL		089-7401-103		
		3	BC, BM				
	DPDT	1	BD, BN	089-7401-122	N/A	N/A	
		2	BE, BO			089-7401-122	
C	SPDT	1	CA, CK	089-7401-110	N/A	N/A	089-7101-022
		2	CB, CL		089-7401-109		
		3	CC, CM				
	DPDT	1	CD, CN	089-7401-125	N/A		
		2	CE, CO			089-7401-125	
D	SPDT	1	DA, DK	089-7401-106	N/A	N/A	089-7101-024
		2	DB, DL		089-7401-105		
		3	DC, DM				
	DPDT	1	DD, DM	089-7401-123	N/A	N/A	
		2	DE, DO			089-7401-123	
F	SPDT	1	FA, FK	089-7401-095	N/A	N/A	089-7101-041
		2	FB, FL			089-7401-096	
	DPDT	1	FD, FN	089-7401-098	N/A	N/A	
		2	FE, FO			089-7401-098	
O	SPDT	3	OC, OM	089-7401-110	089-7401-109	089-7401-110	089-7101-022
	DPDT	3	OE, OK	089-7401-125	089-7401-125	089-7401-125	
Q	SPDT	3	QC, QM	089-7401-104	089-7401-103	089-7401-104	089-7101-020
	DPDT	3	QE, QK	089-7401-122	089-7401-122	089-7401-122	
S	SPDT	1	SA, SK	089-7401-126	N/A		089-7101-022
	DPDT	1	SD, SN	089-7401-128			
S (DC volt)	SPDT	1	SB, SL	089-7401-129	N/A		089-7101-024
	DPDT	1	SE, SO	089-7401-127			

Continued on next page.

6.1.1 Series B, C, D, F, O, Q, S, U, W & X – Yellow (cont.)

Switch Series	Contacts	Quantity	8th & 9th Digits	10th Digit			Switch Only
				E, F, Y, M, W, Q, B, S, K			
				Bottom Mech	Middle Mech	Top Mech	
U	SPDT	1	UA, UK, UU	047-5534-001	N/A	N/A	037-4630-001
		2	UB, UL, UV	047-5534-001	047-5535-001	N/A	
		3	UC, UM, UW	047-5534-001	047-5535-001	047-5534-001	
	DPDT	1	UD, UN, UX	047-6520-001	N/A	N/A	
		2	UE, UO, UY	047-6520-001	047-6520-001	N/A	
W	SPDT	1	WA, WK, WU	089-7410-004	N/A	N/A	037-9101-001
		2	WB, WL, WV	089-7410-004	089-7410-003	N/A	
		3	WC, WM, WW	089-7410-004	089-7410-003	089-7410-004	
	DPDT	1	WD, WN, WX	089-7410-005	N/A	N/A	
		2	WE, WO, WY	089-7410-005	089-7410-005	N/A	
X	SPDT	1	XA, XK, XU	089-7412-004	N/A	N/A	037-9102-001
		2	XB, XL, XV	089-7412-004	089-7412-003	N/A	
		3	XC, XM, XW	089-7412-004	089-7412-003	089-7412-004	
	DPDT	1	XD, XN, XX	089-7412-005	N/A	N/A	
		2	XE, XO, XY, X4	089-7412-005	089-7412-005	N/A	

6.2 Red Dot Magnet Replacement Mechanisms

6.2.1 Series B, C, F, U, W & X – Red, Red/Yellow

Switch Series	Contacts	Quantity	8th & 9th Digits	10th Digit			Switch Only
				G, H, R, D, V, P, A, T, J			
				Bottom Mech	Middle Mech	Top Mech	
B	SPDT	1	BA, BK	089-7401-102	N/A	N/A	089-7101-020
		2	BB, BL		089-7401-101		
		3	BC, BM			089-7401-102	
	DPDT	1	BD, BN	089-7401-121	N/A	N/A	
		2	BE, BO		089-7401-121		
C	SPDT	1	CA, CK	089-7401-108	N/A	N/A	089-7101-022
		2	CB, CL		089-7401-107		
		3	CC, CM			089-7401-108	
	DPDT	1	CD, CN	089-7401-124	N/A	N/A	
		2	CE, CO		089-7401-124		
F	SPDT	1	FA, FK	089-7401-093	N/A	N/A	089-7101-041
		2	FB, FL			089-7401-094	
	DPDT	1	FD, FN	089-7401-097		N/A	
		2	FE, FO			089-7401-097	
U	SPDT	1	UA, UK, UU	047-5533-001	N/A	N/A	037-4630-001
		2	UB, UL, UV	047-5533-001	047-5536-001	N/A	
		3	UC, UM, UW	047-5533-001	047-5536-001	047-5533-001	
	DPDT	1	UD, UN, UX	047-6519-001	N/A	N/A	
		2	UE, UO, UY	047-6519-001	047-6519-001	N/A	

Continued on next page.

6.2.1 Series B, C, F, U, W & X – Red, Red/Yellow (cont.)

Switch Series	Contacts	Quantity	8th & 9th Digits	10th Digit			Switch Only
				G, H, R, D, V, P, A, T, J			
				Bottom Mech	Middle Mech	Top Mech	
W	SPDT	1	WA, WK, WU	089-7410-002	N/A	N/A	089-7411-001
		2	WB, WL, WV	089-7410-002	089-7410-001	N/A	
		3	WC, WM, WW	089-7410-002	089-7410-001	089-7410-002	
	DPDT	1	N/A	N/A			
		2	N/A	N/A			
X	SPDT	1	XA, XK, XU	089-7412-002	N/A	N/A	089-7413-001
		2	XB, XL, XV	089-7412-002	089-7412-001	N/A	
		3	XC, XM, XW	089-7412-002	089-7412-001	089-7412-002	
	DPDT	1	N/A	N/A			
		2	N/A	N/A			

7.0 Switch Housing Replacement Assemblies

When ordering replacement parts for an existing Magnetrol instrument, please specify:

1. Model and serial numbers of control.
2. Description and part number of replacement kit.

The proper replacement switch housing kit and parts can be determined by the last three characters of the model number. In section 6.1.1 on page 18, locate the eighth and ninth digits of your model number at the left side of the chart. Follow the appropriate row across the page while locating the tenth digit of your model number at the top of the chart. In section 6.1.2 on page 18, the chart lists the replacement housing kits according to description.

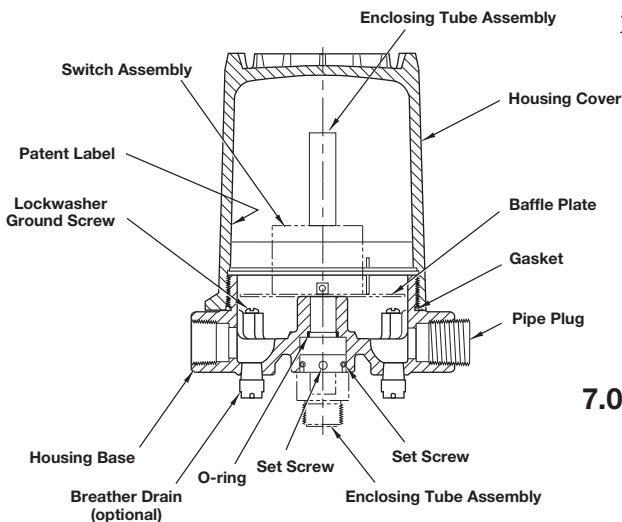

Figure 16
Aluminum Housing Assembly

7.0.1 Aluminum Housings

Die cast aluminum TYPE 4X housing replacements are available for general purpose or weatherproof installations. Explosion proof TYPE 4X/7/9 and Class I, Div 1, Group B housing replacements are available for hazardous atmosphere locations. Die cast aluminum housings are finished with a baked-on polyester powder coat paint.

NOTE: Consult your local representative on applications to meet other codes or approvals not covered in this bulletin.

7.0.2 Cast Iron Housings

Cast Iron TYPE 7/9 housing replacements are available for hazardous atmosphere locations. Both Class I, Div. 1, Groups C & D and Group B versions are available. The grey iron cover and base are finished with a baked-on polyester powder coat paint.

NOTE: Consult your local representative on applications to meet NEMA and other codes not covered in this bulletin.

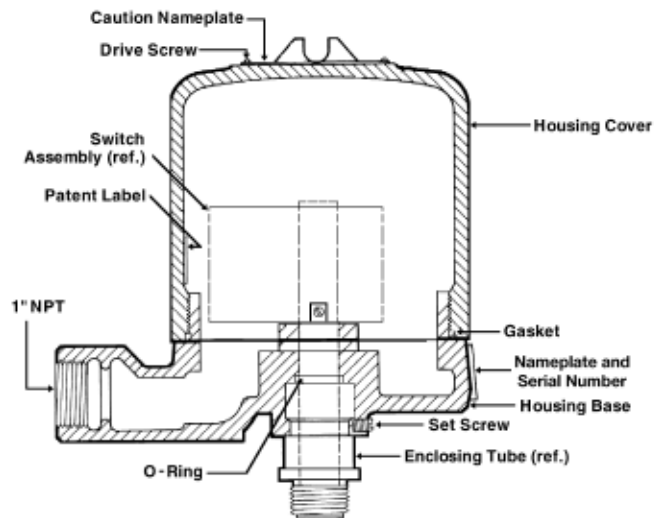

Figure 17
Cast Iron Housing Assembly

7.0.3 Carbon Steel Housings

Carbon steel TYPE 4X switch housings are available for general purpose and weatherproof installations. The housing base is cast from aluminum while the cover is made from cold rolled steel. The housings are finished with a baked-on polyester powder coat paint.

NOTE: Consult your local representative on applications to meet other codes or approvals not covered in this bulletin.

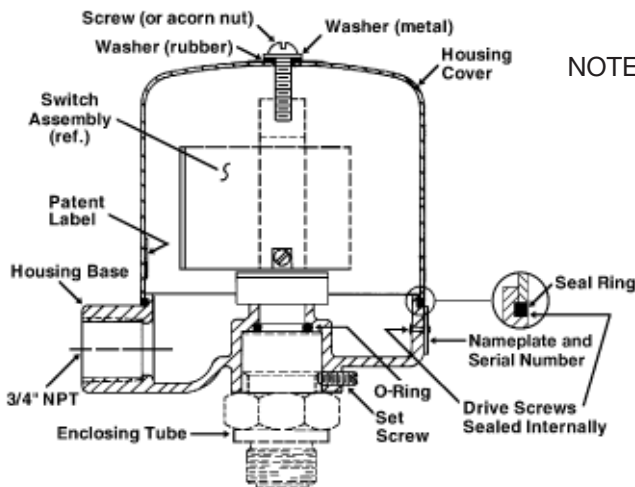

Figure 18
Carbon Steel Housing Assembly

7.1 Replacement Housing Kits ①

7.1.1 Referenced by eighth, ninth and tenth digit

Eighth Digit	Ninth Digit	Tenth Digit						
		E, G, Y, R	P, Q	S, T	F, H, D, M	A, B	J, K, G	V, W
B, C, D, F, G, H, I, S	A, B, C, D, E	089-6509-003②	089-6582-023	N/A	089-6510-003②	089-6582-024	N/A	N/A
	K, L, M, N, O	089-6582-002	089-6582-023	089-6582-032	089-6582-005	089-6582-024	089-6582-033	089-6582-008
	U, V, W, X, Y	089-6582-003	089-6582-028	N/A	089-6582-006	089-6582-029	N/A	N/A
O, Q	A, B, C, D, E	N/A	N/A		089-6528-003	089-6582-025		
	K, L, M, N, O			089-6578-001	089-6582-025			

① Housing kits include o-rings and hardware. Baffle plate not included.

② Cover kit only. Housing base must be ordered separately by P/N 089-6505-003.

7.1.2 Referenced by description

Cover Height	Housing Material	TYPE 1	TYPE 4X	TYPE 4X/7/9	TYPE 7/9	Group B	TYPE 4X/7/9 with drain	TYPE 7/9 with drain
Short	CS cover, aluminum base	089-6511-003②	089-6509-003②	N/A	N/A	N/A		N/A
	Cast aluminum	N/A	089-6582-023	089-6582-023		089-6582-032	089-6582-028	
	Cast Iron		N/A		089-6582-002	N/A		089-6582-003
Tall	CS cover, aluminum base	089-6512-003②	089-6510-003②	N/A	N/A	N/A		N/A
	Cast aluminum	N/A	089-6582-024	089-6582-024		089-6582-033	089-6582-029	
	Cast Iron		N/A		089-6582-005	089-6582-008	N/A	089-6582-006
X-Tall	CS cover, aluminum base	N/A	089-6528-003	N/A	N/A	N/A	N/A	N/A
	Cast aluminum		089-6582-025	089-6582-025				
	Cast Iron		N/A		089-6578-001			

Lexan Cover Kit	089-6522-001②
-----------------	---------------

7.1.3 ATEX Housing Replacements

Housing Material	Part Description	Short		Tall	
		XP	IS	XP	IS
Cast Alum	Cover	089-6582-035	089-6582-036	089-6582-037	089-6582-038
	Base w/ 1" NPT conduit entry	089-6582-041	089-6582-043	089-6582-041	089-6582-043
	Base w/ M20 × 1.5 conduit entry	089-6582-040	089-6582-042	089-6582-040	089-6582-042
Cast Iron	Cover	C/F			
	Base w/ ¾" NPT conduit entry				
	Base w/ M20 × 1.5 conduit entry				

7.2 Replacement Gaskets and Hardware

Housing Material	Enclosure Type	9th Digit	10th Digit	3/4" O-ring	Cover Gasket	Baffle Plate ^③	Cover Hardware
CS cover, aluminum base	Type 4, 4X	A, B, C, D, E	D, E, F, H, R, Y, M, G	12-2201-116	12-1318-001	36-5303-001	089-6508-001
Cast Iron	Type 7/9, 4X/7/9	K, L, M, N, O	D, R, Y, M		12-2201-249	36-5303-001	N/A
Cast Iron	Group B	K, L, M, N, O	V, W		12-2201-222	05-6603-135	
Cast Aluminum	Type 4X	A, B, C, D, E	A, B, P, Q		12-2201-253	05-6657-001	
	Type 4X/7/9, 7/9	K, L, M, N, O	A, B, P, Q				
	Group B	K, L, M, N, O	J, K, S, T				
	ATEX XP	A, B, C, D, E, F, G	C, 9				
	ATEX IS	A, B, C, D, E	S, T				
Cast Iron	ATEX XP	U, V, W, Y, 7	5, 7	N/A	12-1301-005	36-5303-001	

③ For models with manual reset options, see page 23 for parts.

8.0 Manual Reset Option

8.1 Parts Breakdown and Identification

Part No. 089-6507-001, on Boiler Controls Equipped with Manual Reset (*denotes included in kit)

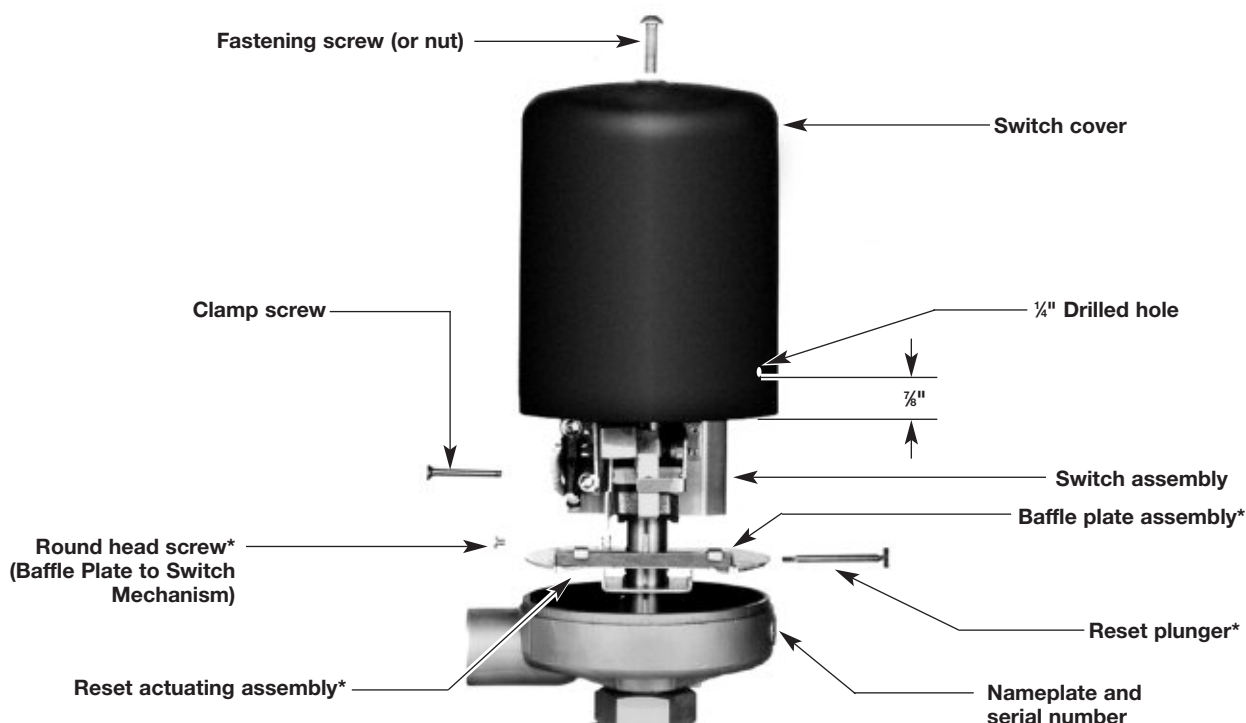

Figure 19

8.2 Field Installation Instructions

Caution: Before attempting work on any level control, be certain to pull disconnect switch or otherwise assure that electrical circuit through control is de-energized.

1. Remove switch cover by loosening fastening screw (or nut).
2. Drill a $\frac{1}{4}$ " diameter hole in cover at $\frac{7}{8}$ " up from bottom edge, as shown.
3. Disconnect wiring from supply side of terminal strip on switch mechanisms.

NOTE: Measure location of switch mechanism(s) on enclosing tube and record for reference use during reassembly. (Measure from top of enclosing tube to top of mounting clamp on switch mechanism[s]).

4. Loosen screw in split mounting clamp of switch mechanism(s) until assembly moves freely on enclosing tube.
5. Remove small round head screw securing baffle plate to switch mechanism.
6. Carefully lift off switch mechanism(s) and baffle plate. Place on a clean surface, free of any metal particles that may be attracted onto the magnet(s).
7. Install a new baffle plate assembly, with manual reset mechanism, and carefully replace switch mechanism(s) in reverse of steps 3 through 6 above.
8. Replace switch cover, lining up drilled hole with hole in reset actuating mechanism. Do not tighten cover fastening screw (or nut) at this point.
9. Thread reset plunger into actuating mechanism through drilled hole in switch cover and thumb tighten securely. Reposition switch cover as necessary to be certain it does not bind reset plunger.
10. Tighten fastening screw (or nut) on switch cover and check action of plunger to see that it moves freely.
11. Vary level in float chamber to test operation of manual reset mechanism.

NOTE: Boiler level controls should not start firing equipment when boiler water level has returned to normal (safe point) until reset plunger has been manually depressed. If control starts firing equipment, magnet stop arm on switch mechanism must be bent out on switch frame $\frac{1}{2}$ " allowing magnet to swing further from enclosing tube arm and into the field of the reset magnet.

Caution: If it is necessary to reposition manual reset plunger, entire switch mechanism(s) must be loosened and rotated on enclosing tube to desired position (refer to step 4). **Do not** attempt to position plunger by twisting switch cover or damage to switch mechanism(s) will result.

9.0 Switch and Housing Model Codes

The following charts identify the switch and housing model codes used with the buoyancy products. The eighth, ninth and tenth digit combinations may be used to identify the type and number of switches, number of contacts, switch magnet strength as well as housing type, size and options. The switch and housing codes in **bold** are currently valid and available in combination with various buoyancy products. The unbolded codes are no longer valid and should be replaced by the appropriate valid code. Mercury switches are no longer available. All mercury switch mechanisms should be replaced by dry contact mechanisms with the appropriate process temperature rating. See switch specifications, page 13.

example model number:

□ □ □ - □ □ □ □ - **B** **K** **A**

9.1 Type 4, 4X, 7, 9 and Group B Enclosure Codes

Switch Type	Housing Height & Options	Switch Contacts	Set Points	Magnet Dot Color	Type 4 Carbon Steel	Type 4X Carbon Steel	Type 7/9 Cast Iron	Type 4X Cast Alum 1" NPT	Type 4X Cast Alum M20 x 1.5	Type 4X/7/9 Cast Alum	Group B Cast Iron	Type 4X/7/9 Group B Cast Alum
Mercury	Short	SPDT	1	Yellow	AAE	AAZ	AKY	AAQ	A2Q	AKQ	—	AKS
				Red	AAG	AAR	AKR	AAP	A2P	AKP	—	AKT
				Yellow	AAF	AAM	AKM	AAB	A2B	AKB	AKW	AKK
				Red	AAH	AAD	AKD	AAA	A2A	AKA	AKV	AKJ
				Yellow	ABF	ABM	ALM	ABB	A4B	ALB	ALW	ALK
				Red	ABH	ABD	ALD	ABA	A4A	ALA	ALV	ALJ
	Tall	SPDT	2	Yellow	ACF	ACM	AMM	ACB	A6B	AMB	AMW	AMK
				Red	ACH	ACD	AMD	ACA	A6A	AMA	AMV	AMJ
				Yellow	ADE	ADY	ANY	ADQ	A8Q	ANQ	—	ANS
				Red	ADG	ADR	ANR	ADP	A8P	ANP	—	ANT
				Yellow	ADF	ADM	ANM	ADB	A8B	ANB	ANW	ANK
				Red	ADH	ADD	AND	ADA	A8A	ANA	ANV	ANJ
	Short	DPDT	1	Yellow	AEF	AEM	AOM	AEB	A1B	AOB	AOW	AOK
				Red	AEH	AED	AOD	AEA	A1A	AOA	AOV	AOJ
				Yellow	—	—	AUY	—	—	AUQ	—	—
				Red	—	—	AUR	—	—	AUP	—	—
				Yellow	—	—	AUM	—	—	AUB	—	—
				Red	—	—	AUD	—	—	AUA	—	—
	Tall	DPDT	2	Yellow	—	—	AVM	—	—	AVB	—	—
				Red	—	—	AVD	—	—	AVA	—	—
				Yellow	—	—	AWM	—	—	AWB	—	—
				Red	—	—	AWD	—	—	AWA	—	—
				Yellow	—	—	AXY	—	—	AXQ	—	—
				Red	—	—	AXR	—	—	AXP	—	—
	Short w/ Drain	SPDT	1	Yellow	—	—	AXM	—	—	AXB	—	—
				Red	—	—	AXD	—	—	AXA	—	—
				Yellow	—	—	AYM	—	—	AYB	—	—
				Red	—	—	AYD	—	—	AYA	—	—
				Yellow	AFE	AFY	APY	AFQ	—	APQ	—	—
				Red	AFG	AFR	APR	AFP	—	APP	—	—
	Tall w/ Drain	SPDT	2	Yellow	AFF	AFM	APM	AFB	—	APB	—	—
				Red	AFH	AFD	APD	AFA	—	APA	—	—
				Yellow	AGF	AGM	AQM	AGB	—	AQB	—	—
				Red	AGH	AGD	AQD	AGA	—	AQA	—	—
				Yellow	AHF	AHM	ARM	AHB	—	ARB	—	—
				Red	AHH	AHD	ARD	AHA	—	ARA	—	—
	Short w/ Heater	DPDT	1	Yellow	AIE	AIY	ASY	AIQ	—	ASQ	—	—
				Red	AIG	AIR	ASR	AIP	—	ASP	—	—
				Yellow	AIF	AIM	ASM	AIB	—	ASB	—	—
				Red	AIH	AID	ASD	AIA	—	ASA	—	—
				Yellow	AJF	AJM	ATM	AJB	—	ATB	—	—
				Red	AJH	AJD	ATD	AJA	—	ATA	—	—

The switch and housing codes in bold are currently valid and available. Those not in bold are no longer valid.

9.1 Type 4, 4X, 7, 9 and Group B Enclosure Codes

Switch Type	Housing Height & Options	Switch Contacts	Set Points	Magnet Dot Color	Type 4 Carbon Steel	Type 4X Carbon Steel	Type 7/9 Cast Iron	Type 4X Cast Alum 1" NPT	Type 4X Cast Alum M20 x 1.5	Type 4X/7/9 Cast Alum	Group B Cast Iron	Type 4X/7/9 Group B Cast Alum
Dry Contact	Short	SPDT	1	Yellow	BAE	BAY	BKY	BAQ	B2Q	BKQ	—	BKS
				Red	BAG	BAR	BKR	BAP	B2P	BKP	—	BKT
				Yellow	BAF	BAM	BKM	BAB	B2B	BKB	BKW	BKK
			2	Red	BAH	BAD	BKD	BAA	B2A	BKA	BKV	BKJ
				Yellow	BBF	BBM	BLM	BBB	B4B	BLB	BLW	BLK
				Red	BBH	BBD	BLD	BBA	B4A	BLA	BLV	BLJ
	3	Yellow	BCF	BCM	BMM	BCB	B6B	BMB	BMW	BMK		
		Red	BCH	BCD	BMD	BCA	B6A	BMA	BMV	BMJ		
		Yellow	BDE	BDY	BNY	BDQ	B8Q	BNQ	—	BNS		
	Tall	DPDT	1	Red	BDG	BDR	BNR	BDP	B8P	BNP	—	BNT
				Yellow	BDF	BDM	BNM	BDB	B8B	BNB	BNW	BNK
				Red	BDH	BDD	BND	BDA	B8A	BNA	BNV	BNJ
			2	Yellow	BEF	BEM	BOM	BEB	B1B	BOB	BOW	BOK
				Red	BEH	BED	BOD	BEA	B1A	BOA	BOV	BOJ
				Yellow	—	—	BUY	—	—	BUQ	—	—
	Short w/ Drain	SPDT	1	Red	—	—	BUR	—	—	BUP	—	—
				Yellow	—	—	BUM	—	—	BUB	—	—
				Red	—	—	BUD	—	—	BUA	—	—
			2	Yellow	—	—	BVM	—	—	BVB	—	—
				Red	—	—	BVD	—	—	BVA	—	—
				Yellow	—	—	BWM	—	—	BWB	—	—
	Tall w/ Drain	DPDT	1	Red	—	—	BXR	—	—	BXP	—	—
				Yellow	—	—	BXM	—	—	BXB	—	—
				Red	—	—	BXD	—	—	BXA	—	—
			2	Yellow	—	—	BYM	—	—	BYB	—	—
				Red	—	—	BYD	—	—	BYA	—	—
				Yellow	BFE	BFY	BPY	BFQ	—	BPQ	—	—
	Short w/ Heater	SPDT	1	Red	BFG	BFR	BPR	BFP	—	BPP	—	—
				Yellow	BFF	BFM	BPM	BFB	—	BPB	—	—
				Red	BFH	BFD	BPD	BFA	—	BPA	—	—
			2	Yellow	BGF	BGM	BQM	BGB	—	BQB	—	—
				Red	BGH	BGD	BQD	BGA	—	BQA	—	—
				Yellow	BHF	BHM	BRM	BHB	—	BRB	—	—
	Tall w/ Heater	DPDT	1	Red	BHH	BHD	BRD	BHA	—	BRA	—	—
				Yellow	BIE	BIY	BSY	BIQ	—	BSQ	—	—
				Red	BIG	BIR	BSR	BIP	—	BSP	—	—
			2	Yellow	BIF	BIM	BSM	BIB	—	BSB	—	—
				Red	BIH	BID	BSD	BIA	—	BSA	—	—
				Yellow	BJF	BJM	BTM	BJB	—	BTB	—	—
	Short	SPDT	1	Red	BJH	BJD	BTD	BJA	—	BTA	—	—
				Yellow	CAE	CAY	CKY	CAQ	C2Q	CKQ	—	CKS
				Red	CAG	CAR	CKR	CAP	C2P	CKP	—	CKT
			2	Yellow	CAF	CAM	CKM	CAB	C2B	CKB	CKW	CKK
				Red	CAH	CAD	CKD	CAA	C2A	CKA	CKV	CKJ
				Yellow	CBF	CBM	CLM	CBB	C4B	CLB	CLW	CLK
	Tall	DPDT	1	Red	CBH	CBD	CLD	CBA	C4A	CLA	CLV	CLJ
				Yellow	CCF	CCM	CMM	CCB	C6B	CMB	CMW	CMK
				Red	CCH	CCD	CMD	CCA	C6A	CMA	CMV	CMJ
			2	Yellow	CDE	CDY	CNY	CDQ	C8Q	CNQ	—	CNS
				Red	CDG	CDR	CNR	CDP	C8P	CNP	—	CNT
				Yellow	CDF	CDM	CNM	CDB	C8B	CNB	CNW	CNK
	Short	DPDT	1	Red	CDH	CDD	CND	CDA	C8A	CNA	CNV	CNJ
				Yellow	CEF	CEM	COM	CEB	C1B	COB	COW	COK
	Tall	DPDT	2	Red	CEH	CED	COD	CEA	C1A	COA	COV	COJ

The switch and housing codes in bold are currently valid and available. Those not in bold are no longer valid.

9.1 Type 4, 4X, 7, 9 and Group B Enclosure Codes

Switch Type	Housing Height & Options	Switch Contacts	Set Points	Magnet Dot Color	Type 4 Carbon Steel	Type 4X Carbon Steel	Type 7/9 Cast Iron	Type 4X Cast Alum 1" NPT	Type 4X Cast Alum M20 x 1.5	Type 4X/7/9 Cast Alum	Group B Cast Iron	Type 4X/7/9 Group B Cast Alum	
Dry Contact	Short w/ Drain	SPDT	1	Yellow	—	—	CUY	—	—	CUQ	—	—	
				Red	—	—	CUR	—	—	CUP	—	—	
				Yellow	—	—	CUM	—	—	CUB	—	—	
			Tall w/ Drain	2	Red	—	—	CUD	—	—	CUA	—	—
					Yellow	—	—	CVM	—	—	CVB	—	—
					Red	—	—	CVD	—	—	CVA	—	—
	Short w/ Drain	DPDT	1	Yellow	—	—	CXY	—	—	CXQ	—	—	
				Red	—	—	CXR	—	—	CXP	—	—	
				Yellow	—	—	CXM	—	—	CXB	—	—	
			Tall w/ Drain	2	Red	—	—	CXD	—	—	CXA	—	—
					Yellow	—	—	CYM	—	—	CYB	—	—
					Red	—	—	CYD	—	—	CYA	—	—
	Short w/ Heater	SPDT	1	Yellow	CFE	CFY	CPY	CFQ	—	CPQ	—	—	
				Red	CFG	CFR	CPR	CFP	—	CPP	—	—	
				Yellow	CFF	CFM	CPM	CFB	—	CPB	—	—	
			Tall w/ Heater	2	Red	CFH	CFD	CPD	CFA	—	CPA	—	—
					Yellow	CGF	CGM	CQM	CGB	—	CQB	—	—
					Red	CGH	CGD	CQD	CGA	—	CQA	—	—
	Short w/ Heater	DPDT	1	Yellow	CHF	CHM	CRM	CHB	—	CRB	—	—	
				Red	CHH	CHD	CRD	CHA	—	CRA	—	—	
				Yellow	CIE	CIY	CSY	CIQ	—	CSQ	—	—	
			Tall w/ Heater	2	Red	CIG	CIR	CSR	CIP	—	CSP	—	—
					Yellow	CIF	CIM	CSM	CIB	—	CSB	—	—
					Red	CIH	CID	CSD	CIA	—	CSA	—	—
DC Voltage Dry Contact	Short	SPDT	1	Yellow	DAE	DAY	DKY	DAQ	D2Q	DKQ	—	DKS	
				Yellow	DAF	DAM	DKM	DAB	D2B	DKB	DKW	DKK	
				Yellow	DBF	DBM	DLM	DBB	D4B	DLB	DLW	DLK	
	Tall	2	Yellow	DCF	DCM	DMM	DCB	D6B	DMB	DMW	DMK		
			Yellow	DDE	DDY	DNY	DDQ	D8Q	DNQ	—	DNS		
			Yellow	DDF	DDM	DNM	DDB	D8B	DNB	DNW	DNK		
Short w/ Drain	DPDT	1	Yellow	DEF	DEM	DOM	DEB	D1B	DOB	DOW	DOK		
			Yellow	—	—	DUY	—	—	DUQ	—	—		
			Yellow	—	—	DUM	—	—	DUB	—	—		
Tall w/ Drain	2	Yellow	—	—	DVM	—	—	DVB	—	—			
		Yellow	—	—	DWM	—	—	DWB	—	—			
		Yellow	—	—	DXY	—	—	DXQ	—	—			
Short w/ Heater	SPDT	1	Yellow	—	—	DXM	—	—	DXB	—	—		
			Yellow	—	—	DYM	—	—	DYB	—	—		
			Yellow	DFE	DFY	DPY	DFQ	—	DPQ	—	—		
Tall w/ Heater	2	Yellow	DFG	DGM	DQM	DGB	—	DQB	—	—			
		Yellow	DGF	DGM	DQM	DGB	—	DQB	—	—			
		Yellow	DHF	DHM	DRM	DHB	—	DRB	—	—			
Short w/ Heater	DPDT	1	Yellow	DIE	DIY	DSY	DIQ	—	DSQ	—	—		
			Yellow	DIF	DIM	DSM	DIB	—	DSB	—	—		
			Yellow	DJF	DJM	DTM	DJB	—	DTB	—	—		

The switch and housing codes in bold are currently valid and available. Those not in bold are no longer valid.

9.1 Type 4, 4X, 7, 9 and Group B Enclosure Codes

Switch Type	Housing Height & Options	Switch Contacts	Set Points	Magnet Dot Color	Type 4 Carbon Steel	Type 4X Carbon Steel	Type 7/9 Cast Iron	Type 4X Cast Alum 1" NPT	Type 4X Cast Alum M20 x 1.5	Type 4X/7/9 Cast Alum	Group B Cast Iron	Type 4X/7/9 Group B Cast Alum	
Vibration Resistant Mercury	Short	SPDT	1	Yellow	EAE	EAY	EKY	EAQ	—	EKQ	—	EKS	
				Red	EAG	EAR	EKR	EAP	—	EKP	—	EKT	
				Yellow	EAF	EAM	EKM	EAB	—	EKB	EKW	EKK	
				Red	EAH	EAD	EKD	EAA	—	EKA	EKV	EKJ	
				Yellow	EBF	EBM	ELM	EBB	—	ELB	ELW	ELK	
				Red	EBH	EBD	ELD	EBA	—	ELA	ELV	ELJ	
	Tall	SPDT	2	Yellow	ECF	ECM	EMM	ECB	—	EMB	EMW	EMK	
				Red	ECH	ECD	EMD	ECA	—	EMA	EMV	EMJ	
				Yellow	EDE	EDY	ENY	EDQ	—	ENQ	—	ENS	
				Red	EDG	EDR	ENR	EDP	—	ENP	—	ENT	
				Yellow	EDF	EDM	ENM	EDB	—	ENB	ENW	ENK	
				Red	EDH	EDD	END	EDA	—	ENA	ENV	ENJ	
	Short	DPDT	1	Yellow	EEF	EEM	EOM	EEB	—	EOB	EOW	EOK	
				Red	EEH	EED	EOD	EEA	—	EOA	EOV	EOJ	
				Yellow	—	—	EUY	—	—	EUQ	—	—	
				Red	—	—	EUR	—	—	EUP	—	—	
				Yellow	—	—	EUM	—	—	EUB	—	—	
				Red	—	—	EUD	—	—	EUA	—	—	
	Tall	DPDT	2	Yellow	—	—	EVM	—	—	EVB	—	—	
				Red	—	—	EVD	—	—	EVA	—	—	
				Yellow	—	—	EWM	—	—	EWB	—	—	
				Red	—	—	EWD	—	—	EWA	—	—	
				Yellow	—	—	EXY	—	—	EXQ	—	—	
				Red	—	—	EXR	—	—	EXP	—	—	
	Short w/ Drain	SPDT	1	Yellow	—	—	EUM	—	—	EUB	—	—	
				Red	—	—	EUD	—	—	EUA	—	—	
				Yellow	—	—	EVM	—	—	EVB	—	—	
				Red	—	—	EVD	—	—	EVA	—	—	
				Yellow	—	—	EWM	—	—	EWB	—	—	
				Red	—	—	EWD	—	—	EWA	—	—	
	Tall w/ Drain	SPDT	2	Yellow	—	—	EVM	—	—	EVB	—	—	
				Red	—	—	EVD	—	—	EVA	—	—	
				Yellow	—	—	EWM	—	—	EWB	—	—	
				Red	—	—	EWD	—	—	EWA	—	—	
				Yellow	—	—	EXM	—	—	EXB	—	—	
				Red	—	—	EXD	—	—	EXA	—	—	
	Short w/ Heater	DPDT	1	Yellow	—	—	EYM	—	—	EYB	—	—	
				Red	—	—	EYD	—	—	EYA	—	—	
				Yellow	—	—	EYM	—	—	EYB	—	—	
				Red	—	—	EYD	—	—	EYA	—	—	
				Yellow	—	—	EYM	—	—	EYB	—	—	
				Red	—	—	EYD	—	—	EYA	—	—	
	Tall w/ Heater	DPDT	2	Yellow	—	—	EYM	—	—	EYB	—	—	
				Red	—	—	EYD	—	—	EYA	—	—	
				Yellow	—	—	EYM	—	—	EYB	—	—	
				Red	—	—	EYD	—	—	EYA	—	—	
				Yellow	—	—	EYM	—	—	EYB	—	—	
				Red	—	—	EYD	—	—	EYA	—	—	
Short w/ Heater	SPDT	1	Yellow	—	—	EYD	—	—	EYA	—	—		
			Red	—	—	EYD	—	—	EYA	—	—		
			Yellow	—	—	EYD	—	—	EYA	—	—		
			Red	—	—	EYD	—	—	EYA	—	—		
			Yellow	—	—	EYD	—	—	EYA	—	—		
			Red	—	—	EYD	—	—	EYA	—	—		
		Tall w/ Heater	SPDT	2	Yellow	—	—	EYD	—	—	EYA	—	—
					Red	—	—	EYD	—	—	EYA	—	—
					Yellow	—	—	EYD	—	—	EYA	—	—
					Red	—	—	EYD	—	—	EYA	—	—
					Yellow	—	—	EYD	—	—	EYA	—	—
					Red	—	—	EYD	—	—	EYA	—	—
Short w/ Heater	DPDT	1	Yellow	—	—	EYD	—	—	EYA	—	—		
			Red	—	—	EYD	—	—	EYA	—	—		
			Yellow	—	—	EYD	—	—	EYA	—	—		
			Red	—	—	EYD	—	—	EYA	—	—		
			Yellow	—	—	EYD	—	—	EYA	—	—		
			Red	—	—	EYD	—	—	EYA	—	—		
Tall w/ Heater	DPDT	2	Yellow	—	—	EYD	—	—	EYA	—	—		
			Red	—	—	EYD	—	—	EYA	—	—		
			Yellow	—	—	EYD	—	—	EYA	—	—		
			Red	—	—	EYD	—	—	EYA	—	—		
			Yellow	—	—	EYD	—	—	EYA	—	—		
			Red	—	—	EYD	—	—	EYA	—	—		
Herm. Sealed Dry Contact	Short	SPDT	1	Yellow	FAE	FAY	FKY	FAQ	F2Q	FKQ	—	FKS	
				Red	FAG	FAR	FKR	FAP	F2P	FKP	—	FKT	
				Yellow	FAF	FAM	FKM	FAB	FCB	FKB	FKW	FKK	
				Red	FAH	FAD	FKD	FAA	FCA	FKA	FKV	FKJ	
				Yellow	FBF	FBM	FLM	FBB	FFB	FLB	FLW	FLK	
				Red	FBH	FBD	FLD	FBA	FFA	FLA	FLV	FLJ	
	Tall	SPDT	2	Yellow	FDE	FDY	FNY	FDQ	F8Q	FNQ	—	FNS	
				Red	FDG	FDR	FNR	FDP	F8P	FNP	—	FNT	
				Yellow	FDH	FDM	FNM	FDB	FGB	FNB	FNW	FNK	
				Red	FDI	FDN	FNN	FDA	FGB	FNA	FNV	FNJ	
				Yellow	FEF	FEM	FOM	FEB	FHB	FOB	FOV	FOK	
				Red	FEH	FED	FOD	FEA	FHA	FOA	FOV	FOJ	

The switch and housing codes in bold are currently valid and available. Those not in bold are no longer valid.

9.1 Type 4, 4X, 7, 9 and Group B Enclosure Codes

Switch Type	Housing Height & Options	Switch Contacts	Set Points	Magnet Dot Color	Type 4 Carbon Steel	Type 4X Carbon Steel	Type 7/9 Cast Iron	Type 4X Cast Alum 1" NPT	Type 4X Cast Alum M20 x 1.5	Type 4X/7/9 Cast Alum	Group B Cast Iron	Type 4X/7/9 Group B Cast Alum
Dual Magnet Dry Contact	Tall	SPDT	1	Yellow	GAF	GAM	GKM	—	—	—	GKW	—
				Red	GAH	GAD	GKD	—	—	—	GKV	—
		DPDT		Yellow	GDF	GDM	GNM	—	—	—	GNW	—
				Red	GDH	GDD	GND	—	—	—	GNV	—
	Tall w/ Drain	SPDT		Yellow	—	—	GUM	—	—	—	—	—
				Red	—	—	GUD	—	—	—	—	—
		DPDT		Yellow	—	—	GXM	—	—	—	—	—
				Red	—	—	GXD	—	—	—	—	—
Dual Magnet Dry Contact	Tall	SPDT	1	Yellow	HAF	HAM	HKM	—	—	—	HKW	—
				Red	HAH	HAD	HKD	—	—	—	HKV	—
		DPDT		Yellow	HDF	HDM	HNM	—	—	—	HNW	—
				Red	HDH	HDD	HND	—	—	—	HNV	—
	Tall w/ Drain	SPDT		Yellow	—	—	HUM	—	—	—	—	—
				Red	—	—	HUD	—	—	—	—	—
		DPDT		Yellow	—	—	HXM	—	—	—	—	—
				Red	—	—	HXD	—	—	—	—	—
DC Voltage Dual Magnet Dry Contact	Tall	SPDT	1	Yellow	IAF	IAM	IKM	—	—	—	IKW	—
				Red	IAH	IAD	IKD	—	—	—	IKV	—
		DPDT		Yellow	IDF	IDM	INM	—	—	—	INW	—
				Red	IDH	IDD	IND	—	—	—	INV	—
	Tall w/ Drain	SPDT		Yellow	—	—	IUM	—	—	—	—	—
				Red	—	—	IUD	—	—	—	—	—
		DPDT		Yellow	—	—	IXM	—	—	—	—	—
				Red	—	—	IXD	—	—	—	—	—
High Temp Mercury for B40	Tall	SPDT	1	Yellow	LAF	LAM	LKM	LAB	L2B	LKB	LKW	LKK
		DPDT			LDF	LDM	LNM	LDB	L8B	LNB	LNW	LNK
		SPDT			LBF	LBM	LLM	LBB	—	LLB	LLW	LLK
		DPDT			LEF	LEM	LOM	LEB	—	LOB	LOW	LOK
High Temp Mercury with Manual Reset* *All Housing on manual reset switches Type/NEMA 1 only.	Short	SPDT	1	Yellow	MAE	MAY	—	—	—	—	—	—
				Red	MAG	MAR	—	—	—	—	—	—
				Yellow	MAF	MAM	—	—	—	—	—	—
				Red	MAH	MAD	—	—	—	—	—	—
	Tall		Yellow	MBF	MBM	—	—	—	—	—	—	
			Red	MBH	MBD	—	—	—	—	—	—	
			R/B	—	MBE	—	—	—	—	—	—	
			Yellow	MCF	MCM	—	—	—	—	—	—	
	Short	DPDT	1	Yellow	MDE	MDY	—	—	—	—	—	—
				Red	MDG	MDR	—	—	—	—	—	
				Yellow	MDF	MDM	—	—	—	—	—	
			Tall	Red	MDH	MDD	—	—	—	—	—	
				Yellow	MEF	MEM	—	—	—	—	—	
				Red	MEH	MED	—	—	—	—	—	
Mercury for C10/C15	X-Tall	SPDT	3	Yellow	NCF	NCM	NMM	NCB	—	NMB	NMI	NMN
		DPDT			NEF	NEM	NKM	NEB	—	NKB	NKI	NKN
	X-Tall w/ Heater	SPDT			NHF	NHM	NRM	NHB	—	NRB	—	
		DPDT			NJF	NJM	NLM	NJB	—	NLB	—	
	X-Tall w/ Drain	SPDT			—	—	NWM	—	—	NWB	—	
		DPDT			—	—	NNM	—	—	NNB	—	
Dry Contact for C10/C15	X-Tall	SPDT	3	Yellow	OCF	OCM	OMM	OCB	—	OMB	OMI	OMN
		DPDT			OEF	OEM	OKM	OEB	—	OKB	OKI	OKN
	X-Tall w/ Heater	SPDT			OHF	OHM	ORM	OHB	—	ORB	—	
		DPDT			OJF	OJM	OLM	OJB	—	OLB	—	
	X-Tall w/ Drain	SPDT			—	—	OWM	—	—	OWB	—	
		DPDT			—	—	ONM	—	—	ONB	—	

The switch and housing codes in bold are currently valid and available. Those not in bold are no longer valid.

9.1 Type 4, 4X, 7, 9 and Group B Enclosure Codes

Switch Type	Housing Height & Options	Switch Contacts	Set Points	Magnet Dot Color	Type 4 Carbon Steel	Type 4X Carbon Steel	Type 7/9 Cast Iron	Type 4X Cast Alum 1" NPT	Type 4X Cast Alum M20 x 1.5	Type 4X/7/9 Cast Alum	Group B Cast Iron	Type 4X/7/9 Group B Cast Alum			
Dry Contact for C10/C15	X-Tall	SPDT	3	Yellow	QCF	QCM	QMM	QCB	—	QMB	QMI	QMN			
		DPDT			QEF	QEM	QKM	QEB	—	QKB	QKI	QKN			
	X-Tall w/ Heater	SPDT			QHF	QHM	QRM	QHB	—	QRB	—	—			
		DPDT			QJF	QJM	QLM	QJB	—	QLB	—	—			
	X-Tall w/ Drain	SPDT			—	—	QWM	—	—	QWB	—	—			
		DPDT			—	—	QNM	—	—	QNB	—	—			
Dry Contact for B40	Tall	SPDT	1	Yellow	SAF	SAM	SKM	SAB	S2B	SKB	SKW	SKK			
DC Dry Contact for B40		DPDT			SDF	SDM	SNM	SDB	S8B	SNB	SNW	SNK			
		SPDT			SBF	SBM	SLM	SBB	S2R	SLB	SLW	SLK			
		DPDT			SEF	SEM	SOM	SEB	S8R	SOB	SOW	SOK			
Vibration Resistant Mercury For C10/C15	X-Tall	SPDT	3	Yellow	TCF	TCM	TMM	TCB	—	TMB	TMI	TMN			
		DPDT			TEF	TEM	TKM	TEB	—	TKB	TKI	TKN			
	X-Tall w/ Heater	SPDT			THF	THM	TRM	THB	—	TRB	—	—			
		DPDT			TJF	TJM	TLM	TJB	—	TLB	—	—			
	X-Tall w/ Drain	SPDT			—	—	TWM	—	—	TWB	—	—			
		DPDT			—	—	TNM	—	—	TNB	—	—			
Dry Contact w/Gold Alloy Contacts	Short	SPDT	1	Yellow	UAE	UAY	UKY	UAQ	U2Q	UKQ	—	—			
				Red	UAG	UAR	UKR	UAP	U2P	UKP	—	—			
				Yellow	UAF	UAM	UKM	UAB	U2B	UKB	UKW	—			
				Red	UAH	UAD	UKD	UAA	U2A	UKA	—	—			
				Tall	2	Yellow	UBF	UBM	ULM	UBB	U4B	ULB	ULW	—	
						Red	UBH	UBD	ULD	UBA	U4A	ULA	—	—	
	Tall	3	Yellow	UCF	UCM	UMM	UCB	U6B	UMB	UMW	—				
			Red	UCH	UCD	UMD	UCA	U6A	UMA	—	—				
			Short	DPDT	1	Yellow	UDE	UDY	UNY	UDQ	U8Q	UNQ	—	—	
						Red	UDG	UDR	UNR	UDP	U8P	UNP	—	—	
			Tall			2	Yellow	UDF	UDM	UNM	UDB	U8B	UNB	UNW	—
							Red	UDH	UDD	UND	UDA	U8A	UNA	—	—
	Tall w/ Drain	SPDT	1			Yellow	UEF	UEM	UOM	UEB	U1B	UOB	UOW	—	
						Red	UEH	UED	UOD	UEA	U1A	UOA	—	—	
				Short w/ Drain	2	Yellow	—	—	—	—	—	UUQ	—	—	
						Red	—	—	—	—	—	—	—	—	
				Tall w/ Drain		3	Yellow	—	—	UUM	—	—	UUB	—	—
							Red	—	—	UUD	—	—	—	—	—
	2	Yellow	—			—	UVM	—	—	UVB	—	—			
		Red	—			—	UVD	—	—	—	—	—			
	Tall w/ Drain	DPDT	1	Yellow	—	—	UWM	—	—	UWB	—	—			
				Red	—	—	UWD	—	—	—	—	—			
				2	Yellow	—	—	—	—	—	UXQ	—	—		
					Red	—	—	—	—	—	—	—	—		
Tall w/ Drain				2	Yellow	—	—	UXM	—	—	UXB	—	—		
					Red	—	—	UXD	—	—	—	—	—		
Hermetically Sealed Dry Contact	Short	SPDT	1	Yellow	WAE	WAY	WKY	WAQ	W2Q	WKQ	—	WKS			
				Red	WAG	WAR	WKR	WAP	W2P	WKP	—	WKT			
				Yellow	WAF	WAM	WKM	WAB	W2B	WKB	WKW	WKK			
				Red	WAH	WAD	WKD	WAA	W2A	WKA	—	—			
				Tall	2	Yellow	WBF	WBM	WLM	WBB	W4B	WLB	WLW	WLK	
						Red	WBH	WBD	WLD	WBA	W4A	WLA	—	—	
	Tall	3	Yellow	WCF	WCM	WMM	WCB	W6B	WMB	WMW	WMK				
			Red	WCH	WCD	WMD	WCA	W6A	WMA	—	—				
			Short	DPDT	1	Yellow	WDE	WDY	WNY	WDQ	W8Q	WNQ	—	WNS	
						Yellow	WDF	WDM	WNM	WDB	W8B	WNB	WNW	WNK	
			Tall			2	Yellow	WFE	WEM	WOM	WEB	W1B	WOB	WOW	WOK

The switch and housing codes in bold are currently valid and available. Those not in bold are no longer valid.

9.1 Type 4, 4X, 7, 9 and Group B Enclosure Codes

Switch Type	Housing Height & Options	Switch Contacts	Set Points	Magnet Dot Color	Type 4 Carbon Steel	Type 4X Carbon Steel	Type 7/9 Cast Iron	Type 4X Cast Alum 1" NPT	Type 4X Cast Alum M20 x 1.5	Type 4X/7/9 Cast Alum	Group B Cast Iron	Type 4X/7/9 Group B Cast Alum		
Hermetically Sealed Dry Contact	Short w/ Drain	SPDT	1	Yellow	—	—	—	—	—	WUQ	—	—		
				Red	—	—	—	—	—	WUP	—	—		
				Yellow	—	—	WUM	—	—	WUB	—	—		
				Red	—	—	WUD	—	—	WUA	—	—		
				Yellow	—	—	WVM	—	—	WVB	—	—		
				Red	—	—	WVD	—	—	WVA	—	—		
	Tall w/ Drain	SPDT	2	Yellow	—	—	WWM	—	—	WWB	—	—		
				Red	—	—	WWD	—	—	WWA	—	—		
				Yellow	—	—	WWM	—	—	WWB	—	—		
				Red	—	—	WWD	—	—	WWA	—	—		
				Yellow	—	—	WWM	—	—	WWB	—	—		
				Red	—	—	WWD	—	—	WWA	—	—		
Short w/ Drain	DPDT	1	Yellow	—	—	—	—	—	WXQ	—	—			
				—	—	WXM	—	—	WXB	—	—			
Tall w/ Drain	DPDT	2	Yellow	—	—	WYM	—	—	—	—	—			
				—	—	—	—	—	—	—	—			
Hermetically Sealed Dry Contact w/Gold	Short	SPDT	1	Yellow	XAE	XAY	XKY	XAQ	X2Q	XKQ	—	XKS		
				Red	XAG	XAR	XKR	XAP	X2P	XKP	—	XKT		
				Yellow	XAF	XAM	XKM	XAB	X2B	XKB	XKW	XKK		
				Red	XAH	XAD	XKD	XAA	X2A	XKA	—	—		
				Yellow	XBH	XBD	XLD	XBA	X4A	XLA	—	—		
				Red	XBF	XBM	XLM	XBB	X4B	XLB	XLW	XLK		
	Tall	SPDT	2	Yellow	XCF	XCM	XMM	XCB	X6B	XMB	XMW	XMK		
				Red	XCH	XCD	XMD	XCA	X6A	XMA	—	—		
				Yellow	XCF	XCM	XMM	XCB	X6B	XMB	XMW	XMK		
				Red	XCH	XCD	XMD	XCA	X6A	XMA	—	—		
				Yellow	XCF	XCM	XMM	XCB	X6B	XMB	XMW	XMK		
				Red	XCH	XCD	XMD	XCA	X6A	XMA	—	—		
	Short	DPDT	1	Yellow	XDE	XDY	XNY	XDQ	X8Q	XNQ	—	XNS		
					XDF	XDM	XNM	XDB	X8B	XNB	XNW	XNK		
	Tall	DPDT	2	Yellow	XEF	XEM	XOM	XEB	X1B	XOB	XOW	XOK		
					—	—	—	—	—	—	—	—		
	Short w/ Drain	SPDT	1	Yellow	—	—	—	—	—	XUQ	—	—		
				Red	—	—	—	—	—	XUP	—	—		
				Yellow	—	—	XUM	—	—	XUB	—	—		
				Red	—	—	XUD	—	—	XUA	—	—		
				Yellow	—	—	XVM	—	—	XVB	—	—		
				Red	—	—	XVD	—	—	XVA	—	—		
		Tall w/ Drain	SPDT	2	Yellow	—	—	XWM	—	—	XWB	—	—	
					Red	—	—	XWD	—	—	XWA	—	—	
Yellow					—	—	XWM	—	—	XWB	—	—		
Red					—	—	XWD	—	—	XWA	—	—		
Yellow					—	—	XWM	—	—	XWB	—	—		
Red					—	—	XWD	—	—	XWA	—	—		
Short w/ Drain	DPDT	1	Yellow	—	—	—	—	—	XXQ	—	—			
				—	—	XXM	—	—	XXB	—	—			
Tall w/ Drain	DPDT	2	Yellow	—	—	XYM	—	—	X4B	—	—			
				—	—	—	—	—	—	—	—			
High Temp Vibration Resistant Mercury	Short	SPDT	1	Yellow	2AE	2AY	2KY	2AQ	22Q	2KQ	—	2KS		
				Red	2AG	2AR	2KR	2AP	22P	2KP	—	2KT		
				Yellow	2AF	2AM	2KM	2AB	22B	2KB	2KW	2KK		
				Red	2AH	2AD	2KD	2AA	22A	2KA	2KV	2KJ		
				Yellow	2BF	2BM	2LM	2BB	24B	2LB	2LW	2LK		
				Red	2BH	2BD	2LD	2BA	24A	2LA	2LV	2LJ		
			Tall	SPDT	2	R/B	—	—	—	2BE	24E	2LE	—	2LG
						Yellow	2CF	2CM	2MM	2CB	26B	2MB	2MW	2MK
						Red	2CH	2CD	2MD	2CA	26A	2MA	2MV	2MJ
						R/B/B	—	—	—	2CE	26E	2ME	—	2MG
						Yellow	2CF	2CM	2MM	2CB	26B	2MB	2MW	2MK
						Red	2CH	2CD	2MD	2CA	26A	2MA	2MV	2MJ
	Short	DPDT	1	Yellow	2DE	2DY	2NY	2DQ	28Q	2NQ	—	2NS		
				Red	2DG	2DR	2NR	2DP	28P	2NP	—	2NT		
				Yellow	2DF	2DM	2NM	2DB	28B	2NB	2NW	2NK		
				Red	2DH	2DD	2ND	2DA	28A	2NA	2NV	2NJ		
				Yellow	2DF	2DM	2NM	2DB	28B	2NB	2NW	2NK		
				Red	2DH	2DD	2ND	2DA	28A	2NA	2NV	2NJ		
			Tall	DPDT	2	Yellow	2EF	2EM	2OM	2EB	21B	20B	20W	20K
						Red	2EH	2ED	2OD	2EA	21A	20A	20V	20J
						Yellow	2EF	2EM	2OM	2EB	21B	20B	20W	20K
						Red	2EH	2ED	2OD	2EA	21A	20A	20V	20J
						Yellow	2EF	2EM	2OM	2EB	21B	20B	20W	20K
						Red	2EH	2ED	2OD	2EA	21A	20A	20V	20J

The switch and housing codes in bold are currently valid and available. Those not in bold are no longer valid.

9.1 Type 4, 4X, 7, 9 and Group B Enclosure Codes

Switch Type	Housing Height & Options	Switch Contacts	Set Points	Magnet Dot Color	Type 4 Carbon Steel	Type 4X Carbon Steel	Type 7/9 Cast Iron	Type 4X Cast Alum 1" NPT	Type 4X Cast Alum M20 x 1.5	Type 4X/7/9 Cast Alum	Group B Cast Iron	Type 4X/7/9 Group B Cast Alum
High Temp Vibration Resistant Mercury	Short w/ Drain	SPDT	1	Yellow	—	—	2UY	—	—	2UQ	—	—
				Red	—	—	2UR	—	—	2UP	—	—
	Yellow			—	—	2UM	—	—	2UB	—	—	
	Tall w/ Drain		2	Red	—	—	2UD	—	—	2UA	—	—
				Yellow	—	—	2VM	—	—	2VB	—	—
				Red	—	—	2VD	—	—	2VA	—	—
	3	R/B	—	—	—	—	—	2VE	—	—		
		Yellow	—	—	2WM	—	—	2WB	—	—		
		Red	—	—	2WD	—	—	2WA	—	—		
	R/B/B	—	—	—	—	—	2WE	—	—			
	Short w/ Drain	DPDT	1	Yellow	—	—	2XY	—	—	2XQ	—	—
				Red	—	—	2XR	—	—	2XP	—	—
	Tall w/ Drain		2	Yellow	—	—	2XM	—	—	2XB	—	—
				Red	—	—	2XD	—	—	2XA	—	—
	3	Yellow	—	—	2YM	—	—	2YB	—	—		
		Red	—	—	2YD	—	—	2YA	—	—		
	Short w/ Heater	SPDT	1	Yellow	2FE	2FY	2PY	2FQ	—	2PQ	—	—
				Red	2FG	2FR	2PR	2FP	—	2PP	—	—
	Yellow			2FF	2FM	2PM	2FB	—	2PB	—	—	
	Tall w/ Heater		2	Red	2FH	2FD	2PD	2FA	—	2PA	—	—
				Yellow	2GF	2GM	2QM	2GB	—	2QB	—	—
				Red	2GH	2GD	2QD	2GA	—	2QA	—	—
	R/B	—	—	—	—	—	2QE	—	—			
	3	Yellow	2HF	2HM	2RM	2HB	—	2RB	—	—		
		Red	2HH	2HD	2RD	2HA	—	2RA	—	—		
	R/B/B	—	—	—	—	—	2RE	—	—			
	Short w/ Heater	DPDT	1	Yellow	2IE	2IY	2SY	2IQ	—	2SQ	—	—
				Red	2IG	2IR	2SR	2IP	—	2SP	—	—
	Tall w/ Heater		2	Yellow	2IF	2IM	2SM	2IB	—	2SB	—	—
				Red	2IH	2ID	2SD	2IA	—	2SA	—	—
3	Yellow	2JF	2JM	2TM	2JB	—	2TB	—	—			
	Red	2JH	2JD	2TD	2JA	—	2TA	—	—			
High Temp Mercury	Short	SPDT	1	Yellow	3AE	3AY	3KY	3AQ	32Q	3KQ	—	3KS
				Red	3AG	3AR	3KR	3AP	32P	3KP	—	3KT
	Yellow			3AF	3AM	3KM	3AB	32B	3KB	3KW	3KK	
	Tall		2	Red	3AH	3AD	3KD	3AA	32A	3KA	3KV	3KJ
				Yellow	3BF	3BM	3LM	3BB	34B	3LB	3LW	3LK
				Red	3BH	3BD	3LD	3BA	34A	3LA	3LV	3LJ
	R/B	—	—	—	3BE	34E	3LE	—	3LG			
	3	Yellow	3CF	3CM	3MM	3CB	36B	3MB	3MW	3MK		
		Red	3CH	3CD	3MD	3CA	36A	3MA	3MV	3MJ		
		R/B/B	—	—	—	3CE	36E	3ME	—	3MG		
	Short	DPDT	1	Yellow	3DE	3DY	3NY	3DQ	38Q	3NQ	—	3NS
				Red	3DG	3DR	3NR	3DP	38P	3NP	—	3NT
	Tall		2	Yellow	3DF	3DM	3NM	3DB	38B	3NB	3NW	3NK
				Red	3DH	3DD	3ND	3DA	38A	3NA	3NV	3NJ
	3	Yellow	3EF	3EM	3OM	3EB	31B	3OB	3OW	3OK		
		Red	3EH	3ED	3OD	3EA	31A	3OA	3OV	3OJ		

The switch and housing codes in bold are currently valid and available. Those not in bold are no longer valid.

9.1 Type 4, 4X, 7, 9 and Group B Enclosure Codes

Switch Type	Housing Height & Options	Switch Contacts	Set Points	Magnet Dot Color	Type 4 Carbon Steel	Type 4X Carbon Steel	Type 7/9 Cast Iron	Type 4X Cast Alum 1" NPT	Type 4X Cast Alum M20 x 1.5	Type 4X/7/9 Cast Alum	Group B Cast Iron	Type 4X/7/9 Group B Cast Alum		
High Temp Mercury	Short w/ Drain	SPDT	1	Yellow	—	—	3UY	—	—	3UQ	—	—		
				Red	—	—	3UR	—	—	3UP	—	—		
	Yellow			—	—	3UM	—	—	3UB	—	—			
	Tall w/ Drain		2	Red	—	—	3UD	—	—	3UA	—	—		
				Yellow	—	—	3VM	—	—	3VB	—	—		
				Red	—	—	3VD	—	—	3VA	—	—		
	Tall w/ Drain	3	R/B	—	—	—	—	—	3VE	—	—			
			Yellow	—	—	3WM	—	—	3WB	—	—			
			Red	—	—	3WD	—	—	3WA	—	—			
	Tall w/ Drain	3	R/B/B	—	—	—	—	—	3WE	—	—			
			Short w/ Drain	DPDT	1	Yellow	—	—	3XY	—	—	3XQ	—	—
						Red	—	—	3XR	—	—	3XP	—	—
	Yellow	—	—			3XM	—	—	3XB	—	—			
	Tall w/ Drain	2	Red		—	—	3XD	—	—	3XA	—	—		
			Yellow		—	—	3YM	—	—	3YB	—	—		
	Red		—		—	3YD	—	—	3YA	—	—			
	Short w/ Heater	SPDT	1	Yellow	3FE	3FY	3PY	3FQ	—	3PQ	—	—		
				Red	3FG	3FR	3PR	3FP	—	3PP	—	—		
	Yellow			3FF	3FM	3PM	3FB	—	3PB	—	—			
	Tall w/ Heater		2	Red	3FH	3FD	3PD	3FA	—	3PA	—	—		
				Yellow	3GF	3GM	3QM	3GB	—	3QB	—	—		
				Red	3GH	3GD	3QD	3GA	—	3QA	—	—		
	Tall w/ Heater	3	R/B	—	—	—	—	—	3QE	—	—			
			Yellow	3HF	3HM	3RM	3HB	—	3RB	—	—			
			Red	3HH	3HD	3RD	3HA	—	3RA	—	—			
	Tall w/ Heater	3	R/B/B	—	—	—	—	—	3RE	—	—			
			Short w/ Heater	DPDT	1	Yellow	3IE	3IY	3SY	3IQ	—	3SQ	—	—
						Red	3IG	3IR	3SR	3IP	—	3SP	—	—
	Yellow	3IF	3IM			3SM	3IB	—	3SB	—	—			
	Tall w/ Heater	2	Red		3IH	3ID	3SD	3IA	—	3SA	—	—		
Yellow			3JF		3JM	3TM	3JB	—	3TB	—	—			
Red	3JH		3JD		3TD	3JA	—	3TA	—	—				

The switch and housing codes in bold are currently valid and available. Those not in bold are no longer valid.

9.2 ATEX Enclosure Codes

Switch Type	Housing Height & Options	Switch Contacts	Set Points	Magnet Dot Color	ATEX XP Cast Iron 3/4" NPT	ATEX XP Cast Iron M20 × 1.5	ATEX XP Cast Alum 1" NPT	ATEX XP Cast Alum M20 × 1.5	ATEX IS Cast Alum 1" NPT	ATEX IS Cast Alum M20 × 1.5	
Mercury	Short	SPDT	1	Yellow	—	—	AA9	AH9	—	—	
				Red	—	—	AAC	AHC	—	—	
				Yellow	AU5	AK5	AC9	AK9	—	—	
			Tall	2	Red	AU7	AK7	ACC	AKC	—	—
					Yellow	AV5	AL5	AD9	AL9	—	—
					Red	AV7	AL7	ADC	ALC	—	—
	Tall	3	1	Yellow	A75	A65	AE9	AM9	—	—	
				Red	A77	A67	AEC	AMC	—	—	
			2	Yellow	—	—	AB9	AJ9	—	—	
				Red	—	—	ABC	AJC	—	—	
				Yellow	AW5	AD5	AF9	AN9	—	—	
				Red	AW7	AD7	AFC	ANC	—	—	
Short	DPDT	1	Yellow	AY5	A05	AG9	AP9	—	—		
			Red	AY7	A07	AGC	APC	—	—		
			Yellow	—	—	BB9	BJ9	—	—		
		Tall	2	Red	—	—	BBC	BJC	—	—	
				Yellow	BW5	BD5	BF9	BN9	—	—	
				Red	BW7	BD7	BFC	BNC	—	—	
Dry Contact	Short	SPDT	1	Yellow	—	—	BA9	BH9	—	—	
				Red	—	—	BAC	BHC	—	—	
				Yellow	BU5	BK5	BC9	BK9	—	—	
			Tall	2	Red	BU7	BK7	BCC	BKC	—	—
					Yellow	BV5	BL5	BD9	BL9	—	—
					Red	BV7	BL7	BDC	BLC	—	—
	Tall	3	1	Yellow	B75	B65	BE9	BM9	—	—	
				Red	B77	B67	BEC	BMC	—	—	
			2	Yellow	—	—	BB9	BJ9	—	—	
				Red	—	—	BBC	BJC	—	—	
				Yellow	BW5	BD5	BF9	BN9	—	—	
				Red	BW7	BD7	BFC	BNC	—	—	
Short	DPDT	1	Yellow	BY5	B05	BG9	BP9	—	—		
			Red	BY7	B07	BGC	BPC	—	—		
			Yellow	—	—	CA9	CH9	CAS	C2S		
		Tall	2	Red	—	—	CAC	CHC	CAL	C2L	
				Yellow	CU5	CK5	CC9	CK9	CAT	C2T	
				Red	CU7	CK7	CCC	CKC	CAX	C2X	
Tall	3	1	Yellow	CV5	CL5	CD9	CL9	CBT	C4T		
			Red	CV7	CL7	CDC	CLC	CBX	C4X		
		2	Yellow	C75	C65	CE9	CM9	—	—		
			Red	C77	C67	CEC	CMC	—	—		
			Yellow	—	—	CB9	CJ9	CDS	C8S		
			Red	—	—	CBC	CJC	CDL	C8L		
Short	DPDT	1	Yellow	CW5	CD5	CF9	CN9	CDT	C8T		
			Red	CW7	CD7	CFC	CNC	CDX	C8X		
			Yellow	CY5	C05	CG9	CP9	CET	C1T		
		Tall	2	Red	CY7	C07	CGC	CPC	CEX	C1X	
				Yellow	—	—	DA9	DH9	—	—	
				Red	DU5	DK5	DC9	DK9	—	—	
DC Voltage Dry Contact	Short	SPDT	1	Yellow	DV5	DL5	DD9	DL9	—	—	
				Red	D75	D65	DE9	DM9	—	—	
			Tall	2	Yellow	—	—	DB9	DJ9	—	—
	Yellow	DW5			DD5	DF9	DN9	—	—		
	Yellow	DY5			D05	DG9	DP9	—	—		
	Vibration Resistant Mercury	Short	SPDT	1	Yellow	—	—	EA9	EH9	—	—
Red					—	—	EAC	EHC	—	—	
Yellow					EU5	EK5	EC9	EK9	—	—	
Tall				2	Red	EU7	EK7	ECC	EKC	—	—
					Yellow	EV5	EL5	ED9	EL9	—	—
					Red	EV7	EL7	EDC	ELC	—	—
Tall		3	1	Yellow	E75	E65	EE9	EM9	—	—	
				Red	E77	E67	EEC	EMC	—	—	

The switch and housing codes in bold are currently valid and available. Those not in bold are no longer valid.

9.2 ATEX Enclosure Codes

Switch Type	Housing Height & Options	Switch Contacts	Set Points	Magnet Dot Color	ATEX XP Cast Iron 3/4" NPT	ATEX XP Cast Iron M20 × 1.5	ATEX XP Cast Alum 1" NPT	ATEX XP Cast Alum M20 × 1.5	ATEX IS Cast Alum 1" NPT	ATEX IS Cast Alum M20 × 1.5		
Vibration Resistant Mercury	Short	DPDT	1	Yellow	—	—	EB9	EJ9	—	—		
				Red	—	—	EBC	EJC	—	—		
				Yellow	EW5	ED5	EF9	EN9	—	—		
	Tall		2	Red	EW7	ED7	EFC	ENC	—	—		
				Yellow	EY5	E05	EG9	EP9	—	—		
				Red	EY7	E07	EGC	EPC	—	—		
Herm. Sealed Dry Contact	Short	SPDT	1	Yellow	—	—	FA9	FH9	—	—		
				Red	—	—	FAC	FHC	—	—		
				Yellow	FU5	FK5	FC9	FK9	—	—		
				Red	FU7	FK7	FCC	FKC	—	—		
				Tall	2	Yellow	FV5	FL5	FD9	FL9	—	—
						Red	FV7	FL7	FDC	FLC	—	—
	Yellow		—			—	—	—	—	—		
	Short		DPDT	1	Red	—	—	—	—	—	—	
					Yellow	—	—	FB9	FJ9	—	—	
					Red	—	—	FBC	FJC	—	—	
	Tall			2	Yellow	FW5	FD5	FF9	FN9	—	—	
					Red	FW7	FD7	FFC	FNC	—	—	
		Yellow			FY5	F05	FG9	FP9	—	—		
	Short	2	Red	FY7	F07	FGC	FPC	—	—			
			Tall	1	Yellow	—	—	LC9	LK9	—	—	
Red					—	—	LF9	LN9	—	—		
Yellow	—	—			LA9	LH9	—	—				
Red	—	—			LB9	LJ9	—	—				
High Temp Mercury for B40	Tall	SPDT	1	Yellow	—	—	SA9	SH9	—	—		
		DPDT			—	—	SB9	SJ9	—	—		
		SPDT			—	—	SC9	SK9	—	—		
		DPDT			—	—	SF9	SN9	—	—		
Dry Contact for B40 DC Dry Contact for B40	Tall	SPDT	1	Yellow	—	—	UA9	UH9	UAS	U2S		
		DPDT			—	—	UAC	UHC	UAL	U2L		
		SPDT			Yellow	UU5	UK5	UC9	UK9	UAT	U2T	
		DPDT			Red	UU7	UK7	UCC	UKC	UAX	U2X	
Dry Contact w/Gold Alloy Contacts	Short	SPDT	1	Yellow	—	—	UD9	UL9	UBT	U4T		
				Red	—	—	UDC	ULC	UBX	U4X		
				Yellow	UV5	UL5	UE9	UM9	UCT	ULT		
				Red	UV7	UL7	UEC	UMC	UCX	ULX		
				Tall	2	Yellow	U75	U65	UB9	UJ9	UDS	U8S
						Red	U77	U67	UBC	UJC	UDL	U8L
	Yellow		—			—	UF9	UN9	UDT	U8T		
	Red		—			—	UFC	UNC	UDX	U8X		
	Short		1			Yellow	UY5	U05	UG9	UP9	UET	U1T
						Red	UY7	U07	UGC	UPC	UEX	U1X
	Tall		2	Yellow	—	—	UGC	UPC	UEX	U1X		
				Red	—	—	UGC	UPC	UEX	U1X		

The switch and housing codes in bold are currently valid and available. Those not in bold are no longer valid.

9.2 ATEX Enclosure Codes

Switch Type	Housing Height & Options	Switch Contacts	Set Points	Magnet Dot Color	ATEX XP Cast Iron 3/4" NPT	ATEX XP Cast Iron M20 × 1.5	ATEX XP Cast Alum 1" NPT	ATEX XP Cast Alum M20 × 1.5	ATEX IS Cast Alum 1" NPT	ATEX IS Cast Alum M20 × 1.5	
Herm. Sealed Dry Contact	Short	SPDT	1	Yellow	—	—	WA9	WH9	WAS	W2S	
				Red	—	—	WAC	WHC	WAL	W2L	
				Yellow	WU5	WK5	WC9	WK9	WAT	W2T	
			Tall	2	Red	WU7	WK7	WCC	WKC	WAX	W2X
					Yellow	WV5	WL5	WD9	WL9	WBT	W4T
					Red	WV7	WL7	WDC	WLC	WBX	W4X
	Short	DPDT	1	Yellow	—	—	WB9	WJ9	WDS	W8S	
				Yellow	WW5	WD5	WF9	WN9	WDT	W8T	
	Tall	2	Yellow	WY5	WO5	WG9	WP9	WET	W1T		
			Red	W77	W67	WEC	WMC	—	—		
	Herm. Sealed Dry Contact w/ Gold	Short	SPDT	1	Yellow	—	—	XA9	XH9	XAS	X2S
					Red	—	—	XAC	XHC	XAL	X2L
Yellow					XU5	XK5	XC9	XK9	XAT	X2T	
Tall				2	Red	XU7	XK7	XCC	XKC	XAX	X2X
					Yellow	XV5	XL5	XD9	XL9	XBT	X4T
					Red	XV7	XL7	XDC	XLC	XBX	X4X
Short		DPDT	1	Yellow	—	—	XB9	XJ9	XDS	X8S	
				Yellow	XW5	XD5	XF9	XN9	XDT	X8T	
Tall		2	Yellow	XY5	XO5	XG9	XP9	XET	X1T		
			Red	X77	X67	XEC	XMC	—	—		
High Temp Vibration Resistant Mercury		Short	SPDT	1	Yellow	—	—	2A9	2H9	—	—
					Red	—	—	2AC	2HC	—	—
	Yellow				2U5	2K5	2C9	2K9	—	—	
	Tall			2	Red	2U7	2K7	2CC	2KC	—	—
					Yellow	2V5	2L5	2D9	2L9	—	—
					Red	—	—	2DC	2LC	—	—
	Short	DPDT	1	R/B	2V7	2L7	2DE	29E	—	—	
				Yellow	275	265	2E9	2M9	—	—	
				Red	—	—	2EC	2MC	—	—	
	Short	2	Yellow	277	267	2EE	28E	—	—		
			Red	—	—	2B9	2J9	—	—		
	Tall	1	Red	—	—	2BC	2JC	—	—		
Yellow			2W5	2D5	2F9	2N9	—	—			
Tall	2	Red	2W7	2D7	2FC	2NC	—	—			
		Yellow	2Y5	2O5	2G9	2P9	—	—			
Tall	2	Red	2Y7	2O7	2GC	2PC	—	—			
		Yellow	—	—	3A9	3H9	—	—			
High Temp Mercury	Short	SPDT	1	Red	—	—	3AC	3HC	—	—	
				Yellow	3U5	3K5	3C9	3K9	—	—	
				Red	3U7	3K7	3CC	3KC	—	—	
			Tall	2	Yellow	3V5	3L5	3D9	3L9	—	—
					Red	—	—	3DC	3LC	—	—
					R/B	3V7	3L7	3DE	39E	—	—
	Short	DPDT	1	Yellow	375	365	3E9	3M9	—	—	
				Red	—	—	3EC	3MC	—	—	
				R/B/B	377	367	3EE	38E	—	—	
	Short	2	Yellow	—	—	3B9	3J9	—	—		
			Red	—	—	3BC	3JC	—	—		
	Tall	1	Yellow	3W5	3D5	3F9	3N9	—	—		
Red			3W7	3D7	3FC	3NC	—	—			
Tall	2	Yellow	3Y5	3O5	3G9	3P9	—	—			
		Red	3Y7	3O7	3GC	3PC	—	—			

The switch and housing codes in bold are currently valid and available. Those not in bold are no longer valid.

NOTES

NOTES

Service Policy

Owners of Magnetrol may request the return of a control or any part of a control for complete rebuilding or replacement. They will be rebuilt or replaced promptly. Controls returned under our service policy must be returned by Prepaid transportation. Magnetrol will repair or replace the control at no cost to the purchaser (or owner) other than transportation if:

1. Returned within the warranty period; and
2. The factory inspection finds the cause of the claim to be covered under the warranty.

If the trouble is the result of conditions beyond our control; or, is NOT covered by the warranty, there will be charges for labor and the parts required to rebuild or replace the equipment.

In some cases it may be expedient to ship replacement parts; or, in extreme cases a complete new control, to replace the original equipment before it is returned. If this is desired, notify the factory of both the model and serial numbers of the control to be replaced. In such cases, credit for the materials returned will be determined on the basis of the applicability of our warranty.

No claims for misapplication, labor, direct or consequential damage will be allowed.

Return Material Procedure

So that we may efficiently process any materials that are returned, it is essential that a "Return Material Authorization" (RMA) number be obtained from the factory, prior to the material's return. This is available through your Magnetrol local representative or by contacting the factory. Please supply the following information:

1. Company Name
2. Description of Material
3. Serial Number
4. Reason for Return
5. Application

Any unit that was used in a process must be properly cleaned in accordance with OSHA standards, before it is returned to the factory.

A Material Safety Data Sheet (MSDS) must accompany material that was used in any media.

All shipments returned to the factory must be by prepaid transportation.

All replacements will be shipped F.O.B. factory.



5300 Belmont Road • Downers Grove, Illinois 60515-4499 • 630-969-4000 • Fax 630-969-9489 • www.magnetrol.com
145 Jardin Drive, Units 1 & 2 • Concord, Ontario Canada L4K 1X7 • 905-738-9600 • Fax 905-738-1306
Heikensstraat 6 • B 9240 Zele, Belgium • 052 45.11.11 • Fax 052 45.09.93
Regent Business Ctr., Jubilee Rd. • Burgess Hill, Sussex RH15 9TL U.K. • 01444-871313 • Fax 01444-871317

Copyright © 2011 Magnetrol International, Incorporated. All rights reserved. Printed in the USA.

BULLETIN: 42-683.15
EFFECTIVE: June 2011
SUPERSEDES: November 2010