



MAGNETROL
REGISTERED TO
ISO 9001
Your Assurance of
Quality and Service

Series G, H, and I Dry Contact Switch Mechanisms

Instruction Manual and Parts List

DESCRIPTION

These switch mechanisms use dry contact switches actuated by a dual magnet rocker arm assembly. Mechanisms are adaptable to most Magnetrol liquid level controls and flow switches. Units are available with a single SPDT switch or two SPDT switches arranged for DPDT operation.

MODEL NUMBER DESCRIPTION

Magnetrol liquid level controls are identified by a ten digit alphanumeric model numbering system. The last three digits of the model number describe the type of switch mechanism furnished.

MODEL NUMBER CONSTRUCTION

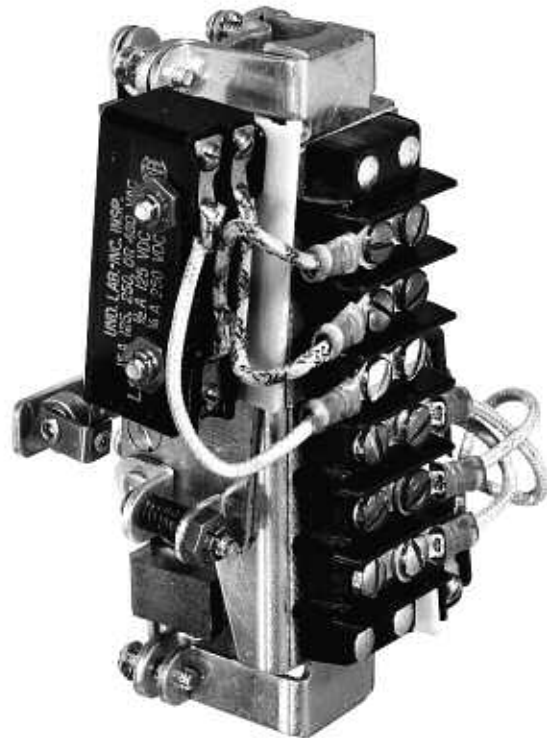
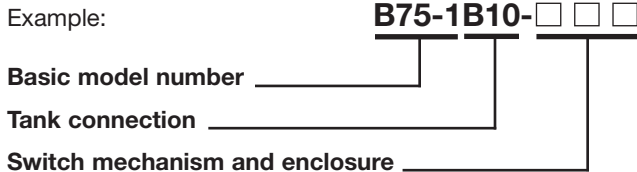

Switch Description	Max. Process Temp. ° F (° C)	One Contact Per Enclosure	Used with Material Code 1				Used with Material Code 2, 3, or 4			
			NEMA 4		NEMA 7/9		NEMA 4		NEMA 7/9	
			Polymer Coated	Polymer Coated	Group B Plymr Ctd	w/Drain Plymr Ctd	Polymer Coated	Polymer Coated	Group B Plymr Ctd	w/Drain Plymr Ctd
Series G Snap Switch	250° F (121° C)	SPDT	GAD	GKD	GKV	GUD	GAM	GKM	GKW	GUM
		DPDT	GDD	GND	GNV	GXD	GDM	GNM	GNW	GXM
Series H Snap Switch	400° F (204° C)	SPDT	HAD	HKD	HKV	HUD	HAM	HKM	HKW	HUM
		DPDT	HDD	HND	HNW	HXD	HDM	HNW	HNW	HXM
Series I Snap Switch	250° F (121° C)	SPDT	IAD	IKD	IKV	IUD	IAM	IKM	IKW	IUM
		DPDT	IDD	IND	INV	IXD	IDM	INM	INW	IXM

Operating principle

Diagrams "A" and "B" illustrate the simple and foolproof operating principle. Switching action is obtained through the use of a magnetic sleeve, actuated by a float (or flow sensing device) and a switching mechanism. These two basic component assemblies are separated by a nonmagnetic, pressure tight enclosing tube. A balanced dual magnet arm, operating on precision stainless steel pivots, actuates the switch.

Operating cycle

At "Normal Operating Level" of a liquid in a storage vessel (diagram "A"), the float moves the magnetic sleeve up within the field of the upper magnet, drawing it in tightly to the enclosing tube. In this position, the switch actuating arm depresses the switch arm "making" one circuit and "breaking" the other circuit of the SPDT switch. As liquid level recedes, the float pulls the magnetic sleeve downward until, at a pre-determined "low level", it releases the upper magnet and simultaneously enters the field of the lower magnet, drawing it in tightly to the enclosing tube. This causes the switch actuating arm to release the switch arm, reversing the switch action.

When liquid level returns to normal, the float once again moves the magnetic sleeve up the enclosing tube, causing the switch to assume its original position.

Switch mechanisms may include a single switch or multiple switches depending on operational requirements and switching action desired.

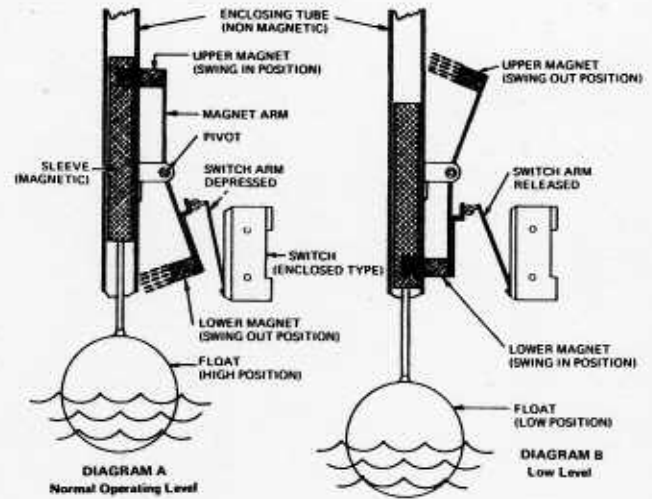
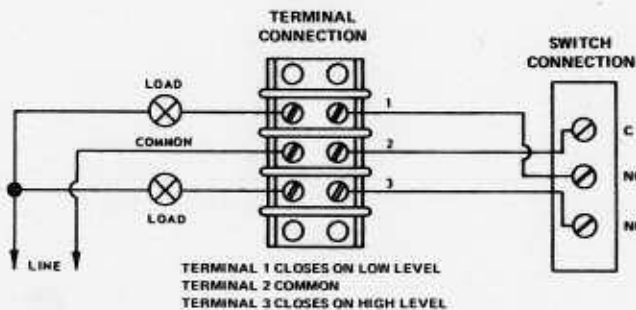

Figure 1

WIRING DIAGRAMS

SPDT MECHANISM Wiring Diagram



NOTE: When used on side mounted float-in-tank models, the wiring diagram is reversed. (Make on Low Level becomes Make on High Level, etc.)

Figure 2

DPDT MECHANISMS Wiring Diagram

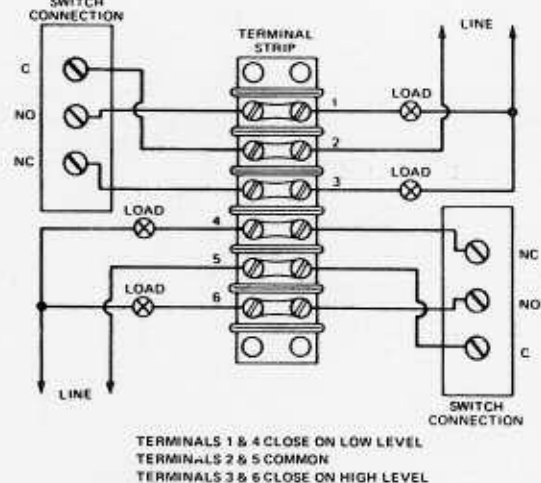

NOTE: When used on side mounted float-in-tank models, the wiring diagram is reversed. (Normally open "NO" becomes normally closed "NC", etc.)

Figure 3

SERVICE INSTRUCTIONS

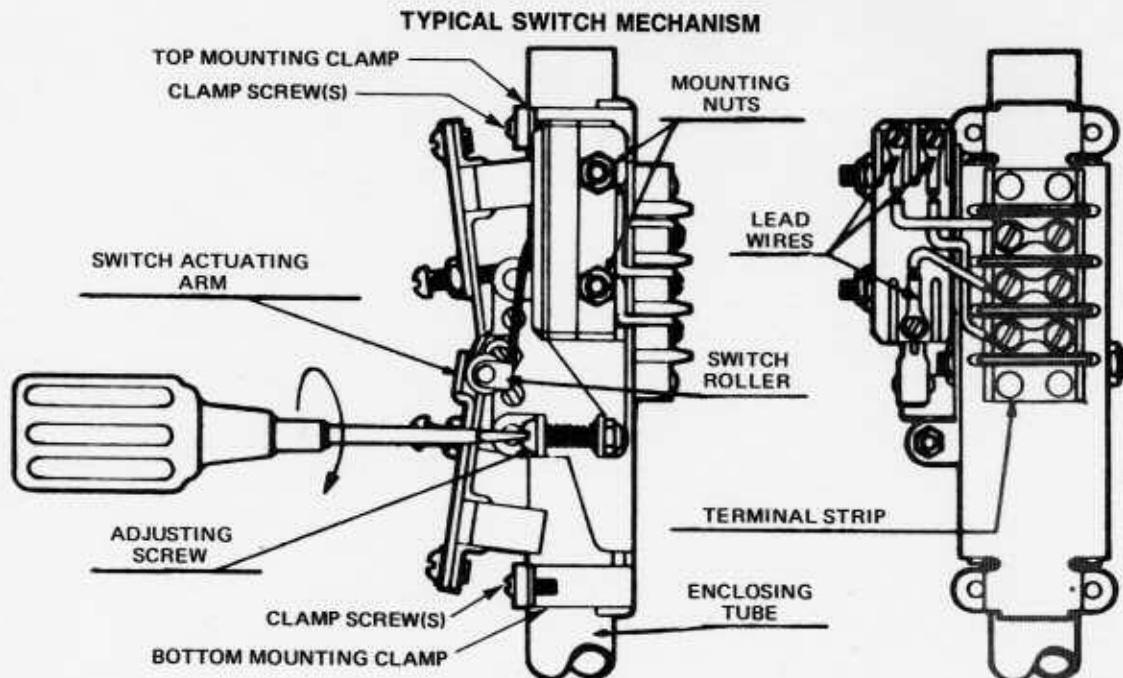

Figure 4

Removing the switch mechanism

All switch mechanisms can be easily removed from a control without disturbing piping connections or the rest of the control. Switch mechanisms are secured in the controls by means of upper and lower mounting clamps.

CAUTION: Before attempting to remove a switch mechanism, be certain to pull disconnect switch or otherwise assure that electrical circuit through control is deenergized.

1. Disconnect wiring from supply side of terminal block(s) on switch mechanism. Note and record lead wire terminal block locations.

NOTE: Measure location of switch mechanism on enclosing tube and record for reference use during reassembly. Measure from top of enclosing tube to top of upper mounting clamp.

2. Loosen screws in upper and lower mounting clamps until mechanism slides freely on enclosing tube.
3. Carefully lift off switch mechanism and place on clean surface, free of metal particles which may be attracted to switch magnets.
4. Replace switch mechanism in reverse of steps 1 through 3 above. Be certain that assembly has the correct end up to insure duplicating original switch action.

NOTE: All switch mechanisms have terminal identification numbers. These numbers should read from top to bottom when switch mechanism is correctly positioned on enclosing tube.

Replacing the switch

Dry contact switches are easily removed and replaced when damaged or broken.

1. Disconnect control from power supply.
2. Disconnect switch leads from terminal block(s) or, if replacement switch is not supplied with lead wires, disconnect leads from switch. Note and record terminal connections of switch being replaced.
3. Remove two mounting nuts holding existing switch.
4. Remove existing switch and install replacement switch in the same position, tightening mounting nuts securely.

CAUTION: Do not overtighten mounting nuts or damage to switch enclosure may occur.

NOTE: For proper operation of the replacement switch, it must actuate (or reset) in the middle portion of magnet arm swing.

5. Check switch action and adjust as follows:
 - A. Slowly rotate magnet arm by hand, back and forth through its full swing, listening closely for the actuating "click" of the switch in each direction.
 - B. Check to see if there is equal additional over-travel of the magnet arm in its swing after the switch "click" in either direction.
 - C. If switch actuation is not correct, change adjustment by turning adjusting screw.

NOTE: On double pole mechanisms, hold switch arm on second switch in depressed position to allow for audible adjustment of new switch only.

- D. With new switch in adjustment, release switch arm of second switch and perform "fine tuning" of both switches to provide simultaneous actuation (required DPDT switch mechanisms only).
6. Re-connect power supply and test switch action by varying liquid level in the vessel or by "blowing down" float chamber.

SWITCH HOUSINGS REPLACEMENT ASSEMBLIES

DESCRIPTION—CAST IRON HOUSINGS

Explosion proof housing replacement assemblies are designed for applications in hazardous atmospheric locations, as classified under types NEMA 7 and 9 of the National Electrical Code. Refer to Figure 5.

IMPORTANT — When ordering, please specify:

1. Model and serial number of control.
2. Name and part number of replacement kit.

NOTE: Consult your local representative on applications to meet NEMA and other codes not covered in this bulletin.

CAST IRON HOUSINGS REPLACEMENT ASSEMBLIES

Description	Replacement Kit Part Number
Explosion proof housing cover 6" (152 mm) and housing base, blue cover	89-6582-005
Explosion proof housing cover 6" (152 mm) and housing base with drain, blue cover	89-6582-006
Class I, Group B housing cover 6" (152 mm) and housing base without drain, blue cover	89-6582-008
Gasket	12-2201-249
O-Ring	12-2201-116

DESCRIPTION—CARBON STEEL HOUSINGS

Standard carbon steel housing replacement assemblies are designed for applications ranging from general purpose, indoor use, to non-hazardous installations requiring a dust/water/lint, fiber/oil tight enclosure. Refer to Figure 6.

- ① Includes assembly hardware kit 89-6508-001.
- ② Includes base assembly hardware.

CARBON STEEL HOUSINGS REPLACEMENT ASSEMBLIES

Description	Replacement Kit Part Number
Standard housing cover 6" (152 mm), NEMA 1 thru 5 & NEMA 12, blue cover	89-6510-003 ①
Housing base, NEMA 1 thru 5 & NEMA 12	89-6505-003 ②
Cover assembly hardware, NEMA 1 thru 5 & NEMA 12	89-6508-001

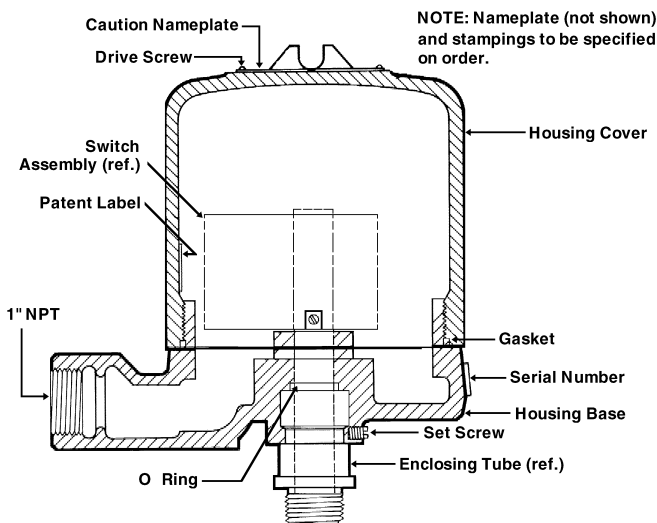

Cast Iron Housing Assembly
Figure 5

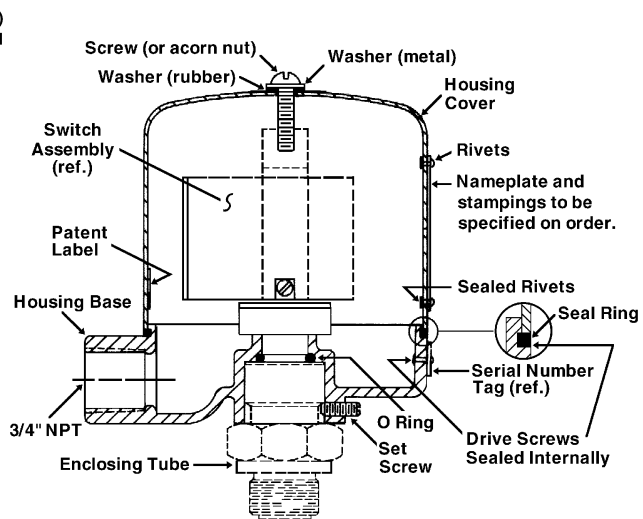

Carbon Steel Housing Assembly
Figure 6

REPLACEMENT PARTS

CAUTION: When ordering replacement switch mechanisms, be certain to determine color dot on magnet. NEVER replace a mechanism that has a red dot magnet with one that has a yellow dot magnet, and vice versa.

Switch Series	Contacts	Replacement Switch Mechanism With Switch (ES)		Replacement Switch Only
		Yellow Dot Magnet	Red Dot Magnet	
G	SPDT	89-7601-002	89-7601-001	89-7101-018
	DPDT	89-7601-006	89-7601-005	89-7101-018 (2 required)
H	SPDT	89-7601-010	89-7601-009	89-7101-016
	DPDT	89-7601-012	89-7601-011	89-7101-016 (2 required)
I	SPDT	89-7601-004	89-7601-003	89-7101-019
	DPDT	89-7601-008	89-7601-007	89-7101-019 (2 required)

IMPORTANT – When ordering, please specify:

1. Model and serial numbers of control.
2. Part name and number.

IMPORTANT

PRODUCT WARRANTY

All Magnetrol mechanical level and flow controls are warranted free of defects in materials or workmanship for five full years from the date of original factory shipment. Repair parts are warranted free of defects in materials and workmanship for one year from the date of shipment. Materials, specifications, and contents are subject to change without prior written notice.

If returned within the warranty period; and, upon factory inspection of the control, the cause of the claim is determined to be covered under the warranty; then, Magnetrol will repair or replace the control at no cost to the purchaser (or owner) other than transportation.

Magnetrol shall not be liable for misapplication, labor claims, direct or consequential damage or expense arising from the installation or use of equipment. There are no other warranties expressed or implied, except special written warranties covering some Magnetrol products.

QUALITY ASSURANCE

The quality assurance system in place at Magnetrol guarantees the highest level of quality throughout the company. Magnetrol is committed to providing full customer satisfaction both in quality products and quality service.



Magnetrol's quality assurance system is registered to ISO 9001 and Z299.1 affirming its commitment to known international quality standards providing the strongest assurance of product/service quality available.

ASSURED QUALITY & SERVICE COST LESS

SERVICE POLICY

Owners of Magnetrol may request the return of a control or any part of a control for complete rebuilding or replacement. They will be rebuilt or replaced promptly. Controls returned under our service policy must be returned by Prepaid transportation. Magnetrol will repair or replace the control at no cost to the purchaser (or owner) other than transportation if:

1. Returned within the warranty period; and
2. The factory inspection finds the cause of the claim to be covered under the warranty.

If the trouble is the result of conditions beyond our control; or, is NOT covered by the warranty, there will be charges for labor and the parts required to rebuild or replace the equipment.

In some cases it may be expedient to ship replacement parts; or, in extreme cases a complete new control, to replace the original equipment before it is returned. If this is desired, notify the factory of both the model and serial numbers of the control to be replaced. In such cases, credit for the materials returned will be determined on the basis of the applicability of our warranty.

No claims for misapplication, labor, direct or consequential damage will be allowed.

RETURN MATERIAL PROCEDURE

So that we may efficiently process any materials that are returned, it is essential that a "Return Material Authorization" (RMA) number be obtained from the factory, prior to the material's return. This is available through Magnetrol's local representative or by contacting the factory. Please supply the following information:

1. Company Name
2. Description of Material
3. Serial Number
4. Reason for Return
5. Application

Any unit that was used in a process must be properly cleaned in accordance with OSHA standards, before it is returned to the factory.

A Material Safety Data Sheet (MSDS) must accompany material that was used in any media.

All shipments returned to the factory must be by prepaid transportation.

All replacements will be shipped F.O.B. factory.



5300 Belmont Road • Downers Grove, Illinois 60515-4499 • 630-969-4000 • Fax 630-969-9489 • www.magnetrol.com
145 Jardin Drive, Units 1 & 2 • Concord, Ontario Canada L4K 1X7 • 905-738-9600 • Fax 905-738-1306
Heikensstraat 6 • B 9240 Zele, Belgium • 052 45.11.11 • Fax 052 45.09.93
Regent Business Ctr., Jubilee Rd. • Burgess Hill, Sussex RH15 9TL U.K. • 01444-871313 • Fax 01444-871317

Copyright © 2009 Magnetrol International, Incorporated. All rights reserved. Printed in the USA.

BULLETIN: 42-684.6
EFFECTIVE: February 1997
SUPERSEDES: February 1991