

Hermetically Sealed Switches

Installation and Operating Manual



*Series HS & H1 with
Aluminum, Carbon
Steel, or Cast Iron
Housings*



Read this Manual Before Installing

This manual provides information on Hermetically Sealed Switch Mechanisms. It is important that all instructions are read carefully and followed in sequence.

Conventions Used in this Manual

Certain conventions are used in this manual to convey specific types of information. General technical material, support data, and safety information are presented in narrative form. The following styles are used for notes, cautions, and warnings.

Notes

Notes contain information that augments or clarifies an operating step. Notes do not normally contain actions. They follow the procedural steps to which they refer.

Cautions

Cautions alert the technician to special conditions that could injure personnel, damage equipment, or reduce a component's mechanical integrity. Cautions are also used to alert the technician to unsafe practices or the need for special protective equipment or specific materials. In this manual, a caution indicates a potentially hazardous situation which, if not avoided, may result in minor or moderate injury.

Warnings

Warnings identify potentially dangerous situations or serious hazards. In this manual, a warning indicates an imminently hazardous situation which, if not avoided, could result in serious injury or death.

WARNING! Explosion hazard. Do not connect or disconnect equipment unless power has been switched off or the area is known to be non-hazardous.

Low Voltage Directive

For use in Installation Category II, Pollution Degree 2. If equipment is used in a manner not specified by manufacturer, protection provided by equipment may be impaired.

Notice of Copyright and Limitations

Copyright © 2009 Magnetrol International, Incorporated. All rights reserved.

Magnetrol reserves the right to make changes to the products described in this manual at any time without notice. Magnetrol makes no warranty with respect to the accuracy of the information in this manual.

Warranty

All Magnetrol mechanical level and flow controls are warranted free of defects in materials or workmanship for five full years from the date of original factory shipment.

If returned within the warranty period; and, upon factory inspection of the control, the cause of the claim is determined to be covered under the warranty; then, Magnetrol will repair or replace the control at no cost to the purchaser (or owner) other than transportation.

Magnetrol shall not be liable for misapplication, labor claims, direct or consequential damage or expense arising from the installation or use of equipment. There are no other warranties expressed or implied, except special written warranties covering some Magnetrol products.

Quality Assurance

The quality assurance system in place at Magnetrol guarantees the highest level of quality throughout the company. Magnetrol is committed to providing full customer satisfaction both in quality products and quality service.

Magnetrol's quality assurance system is registered to ISO 9001 affirming its commitment to known international quality standards providing the strongest assurance of product/service quality available.



1.0 Reference Information

1.1 Principle of Operation

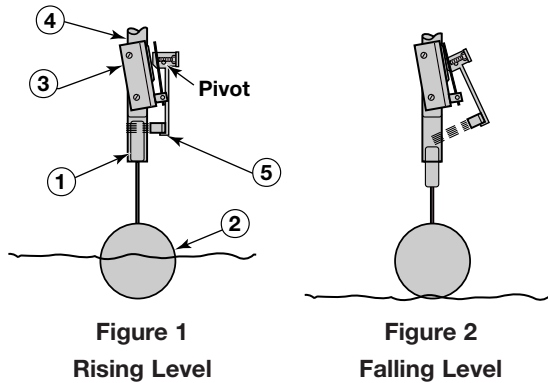

Figures 1 & 2 illustrate the simple and foolproof operating principle of mechanical level switches. Switching action is obtained through the use of a magnetic sleeve ①, actuated by a float, displacer, or flow sensing device ②, and a switching mechanism ③. The basic component assemblies are separated by a non-magnetic, pressure tight enclosing tube ④.

The switch mechanism ③ consists of a magnet ⑤ and a snap acting (dry-contact) microswitch. The magnet is mounted on a swinging arm, which operates on a precision stainless steel pivot. The microswitch is activated by the swinging arm moving the switch lever of the microswitch.

1.2 Operating Cycle

As level of a liquid in a vessel rises (Figure 1), the float rides on the liquid surface moving the magnetic sleeve upward in the enclosing tube and into the field of the switch mechanism magnet. As a result, the magnet is drawn in tightly to the enclosing tube causing the set screw to actuate the switch arm, making or breaking the electrical circuit. As the liquid level recedes (Figure 2), the float and magnetic sleeve move downward until the switch magnet releases and is drawn outward, away from the enclosing tube by a tension spring. This in turn causes the set screw to move the switch actuating arm in the opposite direction, thus reversing switch action.

Switch mechanisms may include a single switch or multiple switches, depending on operational requirements and switching action desired.

1.3 Description

Magnetrol mechanical level controls are available with snap-action micro switches, hermetically sealed in a positively pressurized capsule for extended switch mechanism and contact life.

1.3.1 Features



Figure 3
Hermetically Sealed Switch
with Terminal Block

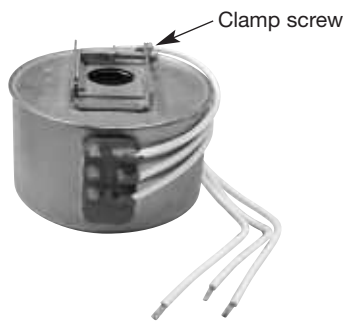

Figure 4
Hermetically Sealed Switch
with Wiring Leads

- Process temperatures from -50° to +750° F (-46° to +399° C).
- Positively pressurized capsule isolates all moving parts of the switch mechanism from the environment.
- Glass-to-metal feed through prevents outside environment from contacting the switch mechanism and isolates the wiring.
- Designed to the hermetic sealing requirements of MIL-S-8805D.
- Direct replacement for most standard switches.
- Switch mechanism enclosed in a 316 stainless steel container.
- Available with SPDT or DPDT contacts.
- Standard HS switch contacts are silver (contact factory for optional gold contacts).
- H1 switch contacts are platinum.
- 12" (305 mm) long exposed wiring leads allow for connection away from the switch enclosure.
- CSA, FM, ATEX and IEC approved for hazardous and non-hazardous locations on selected models.
- Strain relief design prevents shearing from vibration and extends wiring life.

1.3.2 Applications

- Feedwater heater high and low alarm
- Primary steam drip pot
- Refinery applications
- Paper processing H₂S atmosphere
- Offshore salt atmosphere
- Chemical plant corrosive atmosphere
- High temperature reactors, high and low alarm

1.4 Switch Specifications

Switch Series	Switch Codes	Switch Type	Contact Material	Process Temperature Range ①	Load	Rating					
						Volts AC			Volts DC		
						120	240	480	24	120	240
H1	H8, HK	Hermetic	Platinum	-50° to +750° F (-46 to +399° C)	Non-inductive Amp Inductive Amp	1.0 1.0	1.0 1.0	— —	1.0 1.0	0.4 0.4	— —
HS	HA, HB, HE, HM, HS, HW	Hermetic	Silver	-50° to +550° F ② (-46 to +288° C)	Non-inductive Amp Inductive Amp Horsepower	5.0 — %	5.0 — %	— — —	5.0 3.0 —	0.5 — —	0.25 — —
(X)HS (x=gold contacts)	Consult Factory	Hermetic	Gold Overlay	-50° to +550° F ② (-46 to +288° C)	Non-inductive Amp Inductive Amp	1.0 —	— —	— —	2.0 1.0	— —	— —

① Process temperatures are based on -40° to +160° F (-40° to +71° C) ambient temperatures

② On steam applications, temperature down-rated to +400° F (+204° C) process at +100° F (+38° C) ambient

2.0 Wiring

Circuits shown are for direct acting level switches and are reversed in side mounting float-in-tank models, which utilize a reversing float pivot.

2.1 Switch with Terminal Block

1. Make sure power to control wires is disconnected.
2. Remove switch housing cover.
 - a. NEMA 4X – Remove screw, washer, and grommet at top of housing. Set aside.
 - b. NEMA 4X/7/9 – Unscrew cover and set aside.
3. Bring in control wires through conduit connection.
4. Wire the switch as shown in figures below:
 - a. SPDT Switch – Refer to Figure 5.
 - b. DPDT Switch – Refer to Figure 6.

NOTE: Double pole action is obtained by simultaneous operation of the right and left side SPDT switches.

5. Dress wiring to ensure no interference or contact with switch housing cover during replacement.

NOTE: Observe all applicable electrical codes and proper wiring procedures.

6. Prevent moisture seepage into the enclosure by installing approved seal-drain fittings in the conduit run leading into the unit.

Caution: In hazardous areas, do not power the unit until the enclosure cover is screwed down securely and properly sealed.

7. Replace housing cover.
8. Turn on power to the unit.
9. Test switch action by varying liquid level in float chamber.
10. Check cover to base fit to be certain gasketed joint is tight. A positive seal is necessary to prevent infiltration of moisture laden air or corrosive gases into switch housings.

NOTE: If switch mechanism fails to function properly, check vertical alignment of control housing.

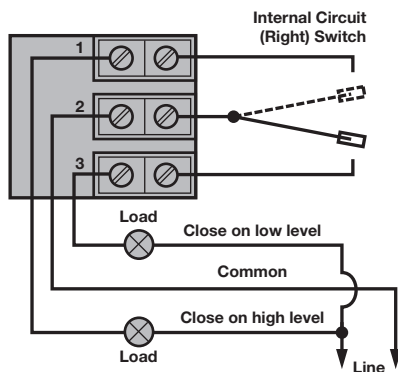

Figure 5

SPDT Terminals for Series HS only

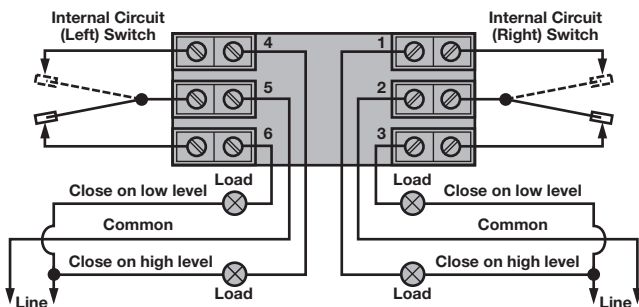

Figure 6

DPDT Terminals for Series HS only

2.2 Switch with Wiring Leads

1. Make sure power to control wires is disconnected.
2. Remove switch housing cover.
 - a. NEMA 4X – Remove screw, washer, and grommet at top of housing. Set aside.
 - b. NEMA 4X/7/9 – Unscrew cover and set aside.
3. Wiring leads will extend through conduit connection of the switch housing base. Each wiring lead is marked with a number from 1 to 3 for SPDT switches, or 1 to 6 for DPDT switches. Refer to Figures 7–9. These numbers correspond to the numbers marked on the terminal block models.
4. Wire the switch as shown in Figures 7–9.

NOTE: Observe all applicable electrical codes and proper wiring procedures.

Caution: In hazardous areas, do not power the unit until the enclosure cover is screwed down securely and properly sealed.

5. Replace housing cover.
6. Turn on power to the unit.
7. Test switch action by varying liquid level in the float chamber of the control.
8. Check cover to base fit to be certain gasketed joint is tight.

NOTE: If switch mechanism fails to function properly, check vertical alignment of control housing.

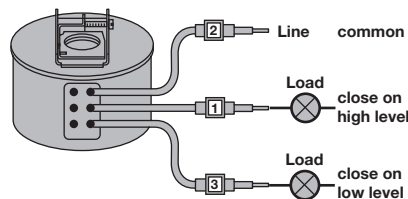

Figure 7
SPDT Terminals for Series H1 only

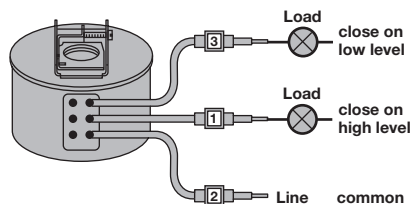

Figure 8
SPDT Terminals for Series HS only

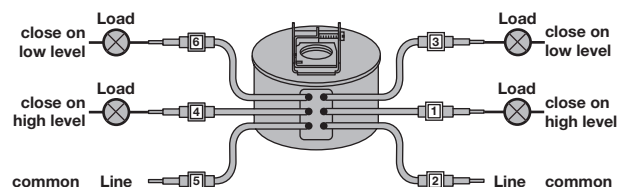

Figure 9
DPDT Terminals for Series HS only

3.0 Replacement Parts

Replacement parts for hermetically sealed switch mechanisms are available as a kit only. The kit consists of a switch assembly, a tubular spacer, and a flat switch washer. When ordering a kit, please be sure to specify:

1. The model number of the level control in which the switch is installed, for example B75-1B20-HSA.
2. The serial number of the level control in which the switch is installed (located on the plate attached to the control).
3. The model code of the switch being replaced, e.g., HSA.
4. The part number of the replacement switch kit.
5. The quantity of replacement switch kits.

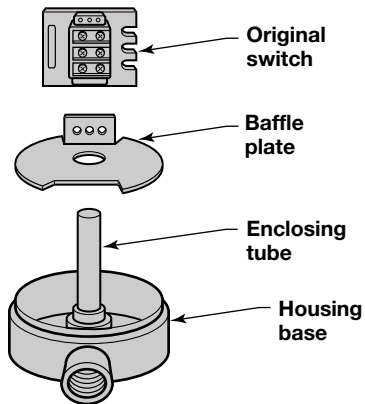

Figure 10
Original Switch Configuration

3.1 Replacement of the Switch Mechanism

Should the switch need to be replaced, it may be done by performing the following steps:

1. Disconnect all power to the control.
 2. Remove switch housing cover.
 3. Remove all control wiring from the switch terminal block or wiring leads.
 4. Loosen the clamp screw at the top of the switch by turning it counterclockwise. Refer to Figure 4 on page 4.
 - 5a. **If replacing an existing single hermetically sealed switch:** Lift the switch assembly and the switch spacer or washer off of the enclosing tube. Discard these parts.
 - b. **If replacing a single switch which used a baffle plate:** Lift the entire switch assembly and the baffle plate off the enclosing tube. Retain baffle plate for identification of type. Discard the switch assembly. Refer to Figure 10.
- NOTE: If replacing two switches which were nested (terminals opposite), the top switch will activate when the level is 1" (25 mm) higher than the original actuation level.
- c. **If replacing two existing hermetically sealed switches with wiring leads:** Lift both switch assemblies and the switch spacer or washer off of the enclosing tube. Discard these parts.
 - d. **If replacing two (terminals in line) stacked switches which used a baffle plate:** Lift both switch assemblies and the baffle plate off of the enclosing tube. Discard these parts.
 - 6a. For all switch housings with baffle plates, examine the baffle plate to determine which type it is. A "Type A" baffle plate has a bracket riveted to the bottom of the plate. See Figure 12 on page 8. A "Type B" baffle plate has no such bracket. See Figure 13 on page 8.

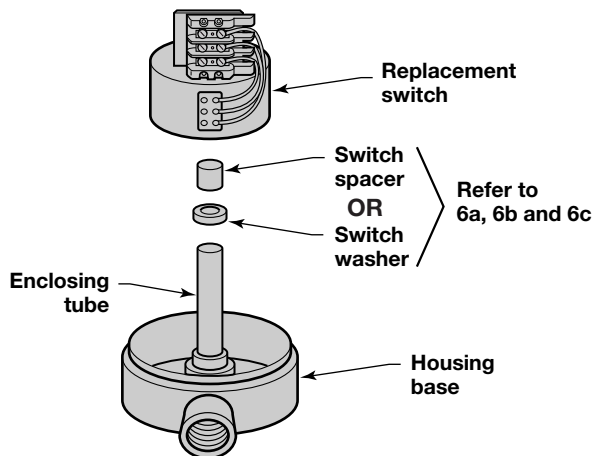

Figure 11
Replacement Switch

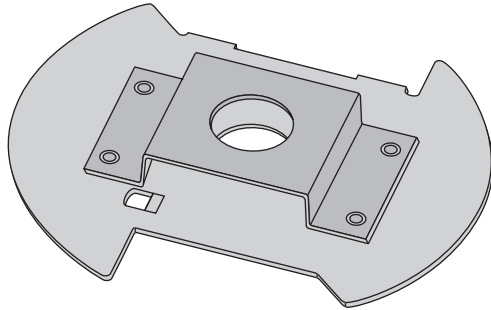

Figure 12
“Type A” Baffle Plate
(with bracket)

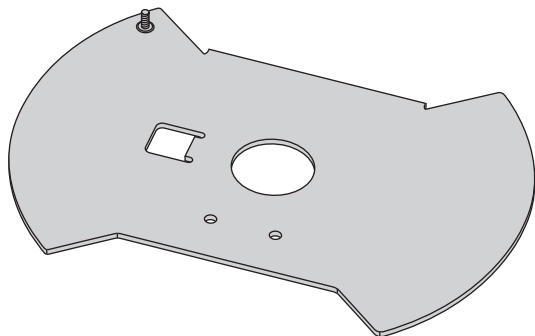

Figure 13
“Type B” Baffle Plate
(no bracket)

- b. **For all switch housings with Type A baffle plates:** Slide the new tubular switch spacer over the enclosing tube. Discard the switch washer included in the replacement switch parts kit.
- c. **For switch housings with Type B baffle plates:** Slide the new switch washer over the enclosing tube. Discard the tubular switch spacer included in the replacement switch parts kit.

Caution: When replacing switches which used baffle plates, either the switch spacer or the washer must be used to ensure that the actuation levels for the control remain the same.

- 7a. **Single switches:** Slide the new hermetically sealed switch over the enclosing tube until it rests on top of the switch spacer or washer. Refer to Figure 11 on page 7.
- b. **Two switches with wiring leads:** Slide one new hermetically sealed switch over the enclosing tube until it rests on top of the switch spacer or washer. Slide the second switch over the enclosing tube until it rests on top of the first switch. Discard the spacer and washer included in the second switch’s parts kit.

Caution: When replacing a hermetically sealed switch with wiring leads, be sure the side of the switch with the clamp screw is on top. The switch will not actuate if it is installed upside down.

8. Tighten the clamp screw at the top of the switch by turning it clockwise until the switch is secure on the enclosing tube.
9. Replace the control wires on the appropriate terminals or wiring leads of the new switch. Refer to Figures 5–9 on pages 3–4 as necessary.
10. Replace the switch housing cover.
11. Turn on power to the unit.
12. Test switch action by varying liquid level in the float chamber.

REPLACEMENT SWITCH MECHANISMS

Switch Series	Contacts	Quantity	8th, 9th & 10th Digits	Bottom Mech	Top Mech
HS Terminal Block ①	SPDT	1	HA9, HM3, HM4	89-8301-002	n/a
	DPDT	1	HB9, HM7, HM8	89-8301-001	n/a
HS Wiring Leads ①	SPDT	1	HMC, HEK, HMJ, HMK	89-8301-004	n/a
		2	HMN, HMP		89-8301-004
	DPDT	1	HMF, HET, HMS, HMT	89-8301-003	n/a
		2	HMY, HMZ		89-8301-003
H1 Wiring Leads	SPDT	1	HKC, HKJ, HKK	89-8301-015	n/a
		2	HKN, HKP		89-8301-015
	DPDT	1	n/a	n/a	n/a
		2			

① HS switch available with gold contacts. Consult factory.

4.0 Switch Housing Replacement Assemblies

When ordering replacement parts for an existing Magnetrol instrument, please specify:

1. Model and serial numbers of control.
2. Description and part number of replacement kit.

The proper replacement switch housing kit and parts can be determined by the last three characters of the model number. In Section 5.0, Switch and Housing Model Codes on page 11, locate the eighth, ninth and tenth digit combination of your model number in the chart. The heading of the column in which your combination is located identifies the housing material. Follow the row in which your code is located to the right to identify the housing height.

Replacement housing kits are listed according to cover height and housing material in Section 4.1 below.

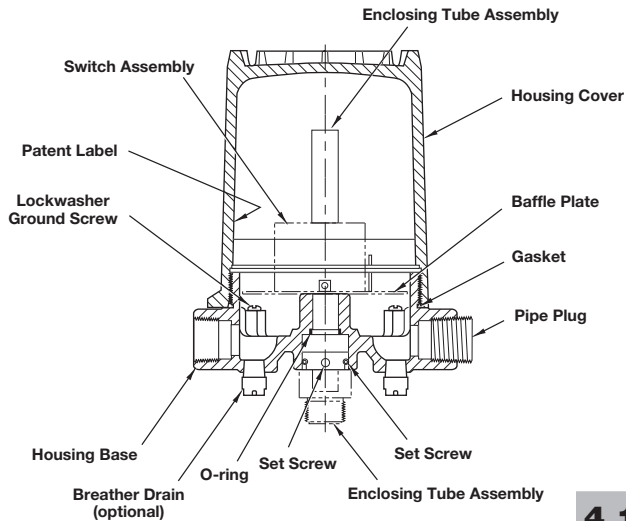

Figure 14
Aluminum Housing Assembly

4.1 Aluminum Housings

Die cast aluminum NEMA 4X housing replacements are available for general purpose or weather proof installations. Explosion proof NEMA 4X/7/9 and Class I, Div 1, Group B housing replacements are available for hazardous atmosphere locations. Die cast aluminum housings are finished with a baked-on polyester powder coat paint.

NOTE: Consult your local representative on applications to meet NEMA and other codes not covered in this bulletin.

REPLACEMENT PARTS

Cover Height	Housing Material	NEMA 4X	NEMA 4X/7/9	NEMA 7/9	Group B
Short	CS cover, alum base	89-6509-003	n/a	n/a	n/a
	Cast Aluminum	89-6582-023	89-6582-023		89-6592-032
	Cast Iron	n/a		89-6582-002	n/a
Tall	CS cover, alum base	89-6510-003	n/a	n/a	n/a
	Cast Aluminum	89-6582-024	89-6582-024		89-6582-033
	Cast Iron	n/a		89-6582-005	89-6582-008

Housing Material	Enclosure Type	Gasket	O-ring	Cover Hardware
CS cover, alum base	NEMA 4X	n/a	n/a	89-6508-001
Cast Aluminum	NEMA 4X	12-2201-253	12-2201-116	n/a
	NEMA 4X/7/9			
Group B				
Cast Iron	NEMA 7/9	12-2201-249	12-2201-116	n/a
	7/9 with drain			
	Group B			

4.2 Cast Iron Housings

Cast Iron NEMA 7/9 housing replacements are available for hazardous atmosphere locations. Both Class I, Div. 1, Groups C & D and Group B versions are available. The grey iron cover and base are finished with a baked-on polyester powder coat paint.

NOTE: Consult your local representative on applications to meet NEMA and other codes not covered in this bulletin.

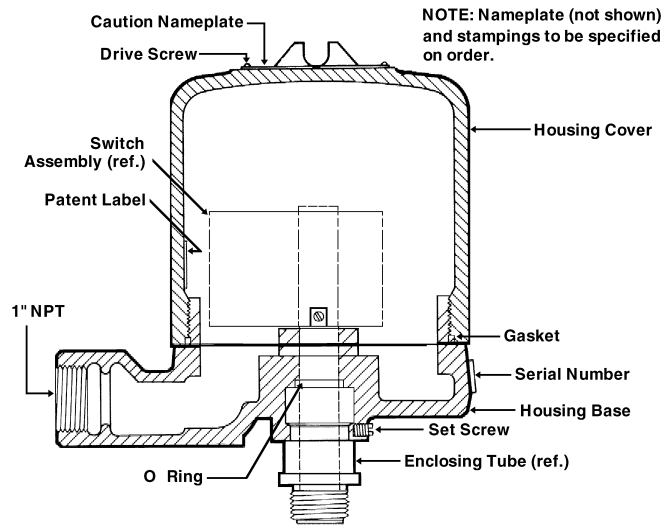

Figure 15
Cast Iron Housing Assembly

4.3 Carbon Steel Housings

Carbon steel NEMA 4X switch housings are available for general purpose and weather proof installations. The housing base is cast from aluminum while the cover is made from cold rolled steel. The housings are finished with a baked-on polyester powder coat paint.

NOTE: Consult your local representative on applications to meet NEMA and other codes not covered in this bulletin.

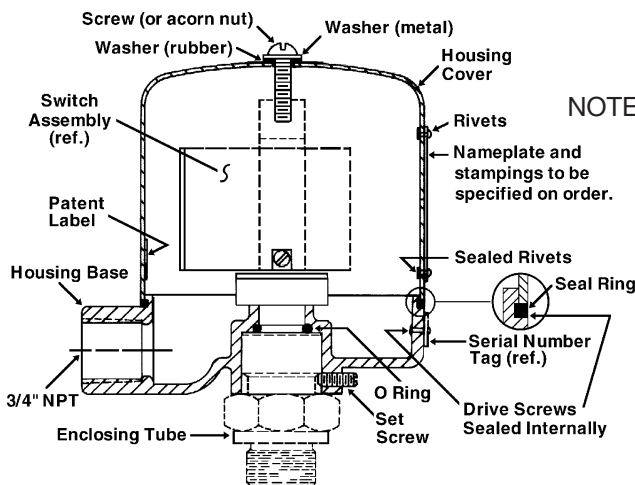

Figure 16
Carbon Steel Housing Assembly

5.0 Switch and Housing Model Codes

The following charts identify the switch and housing model codes used with the buoyancy products. The eighth, ninth and tenth digit combinations may be used to identify the type and number of switches, number of contacts, switch magnet strength as well as housing type, size and options. The switch and housing codes in bold are currently valid and available in combination with various buoyancy products. The unbolded codes are no longer valid and should be replaced by the appropriate valid code.

example model number:

□ □ □ - □ □ □ □ - **H 8 B**

NEMA 4 Carbon Steel	NEMA 4X Carbon Steel	NEMA 7/9 Cast Iron	NEMA 4X Cast Aluminum	NEMA 4X/7/9 Cast Aluminum	Group B Cast Iron	NEMA 4X/7/9 Group B Cast Aluminum	ATEX Cast Aluminum 1" NPT	Wiring Type	Set Points	Switch Contacts	Housing Height	Switch Type
HSA	HSB	HSC	HMB	HMC	—	HEK	—	Pigtails	1	SPDT	Short	550° F 5 Amp
HSD	HSE	HSF	HME	HMF	—	HET	—			DPDT		
HSG	HSH	HSJ	HMH	HMJ	HSK	HMK	—			SPDT	Tall	
HSQ	HSR	HSS	HMR	HMS	HST	HMT	—		DPDT			
HSL	HSM	HSN	HMM	HMN	HSP	HMP	—		SPDT			
HSW	HSX	HSY	HMX	HMY	HSZ	HMZ	—		DPDT			
HWY	HWV	HWS	—	HES	—	—	—	Terminal Block	1	SPDT	Short	
HWU	HWZ	HWW	—	HEW	—	—	—			DPDT		
HS1	HS2	HS3	HM2	HM3	HS4	HM4	HA9		SPDT	Tall		
HS5	HS6	HS7	HM6	HM7	HS8	HM8	HB9		DPDT			
H8A	H8B	H8C	HKB	HKC	—	—	—	Pigtails	1	SPDT	Short	750° F 10 Amp
H8G	H8H	H8J	HKH	HKJ	H8K	HKK	—				2	
H8L	H8M	H8N	HKZ	HKN	H8P	HKP	—					

For gold contact option, consult factory.

Service Policy

Owners of Magnetrol controls may request the return of a control or any part of a control for complete rebuilding or replacement. They will be rebuilt or replaced promptly. Controls returned under our service policy must be returned by Prepaid transportation. Magnetrol will repair or replace the control at no cost to the purchaser (or owner) other than transportation if:

1. Returned within the warranty period; and
2. The factory inspection finds the cause of the claim to be covered under the warranty.

If the trouble is the result of conditions beyond our control; or, is NOT covered by the warranty, there will be charges for labor and the parts required to rebuild or replace the equipment.

In some cases it may be expedient to ship replacement parts; or, in extreme cases a complete new control, to replace the original equipment before it is returned. If this is desired, notify the factory of both the model and serial numbers of the control to be replaced. In such cases, credit for the materials returned will be determined on the basis of the applicability of our warranty.

No claims for misapplication, labor, direct or consequential damage will be allowed.

Return Material Procedure

So that we may efficiently process any materials that are returned, it is essential that a "Return Material Authorization" (RMA) number be obtained from the factory, prior to the material's return. This is available through Magnetrol's local representative or by contacting the factory. Please supply the following information:

1. Company Name
2. Description of Material
3. Serial Number
4. Reason for Return
5. Application

Any unit that was used in a process must be properly cleaned in accordance with OSHA standards, before it is returned to the factory.

A Material Safety Data Sheet (MSDS) must accompany material that was used in any media.

All shipments returned to the factory must be by prepaid transportation.

All replacements will be shipped F.O.B. factory.

