

Boiler Controls

Installation and Operating Manual



External

Cage

Float

Actuated

Liquid

Level

Switches

Read this Manual Before Installing

This manual provides information on the Boiler Controls External Cage Liquid Level Switches. It is important that all instructions are read carefully and followed in sequence. Detailed instructions are included in the Installation section of this manual.

Conventions Used in this Manual

Certain conventions are used in this manual to convey specific types of information. General technical material, support data, and safety information are presented in narrative form. The following styles are used for notes, cautions, and warnings.

Notes

Notes contain information that augments or clarifies an operating step. Notes do not normally contain actions. They follow the procedural steps to which they refer.

Cautions

Cautions alert the technician to special conditions that could injure personnel, damage equipment, or reduce a component's mechanical integrity. Cautions are also used to alert the technician to unsafe practices or the need for special protective equipment or specific materials. In this manual, a caution indicates a potentially hazardous situation which, if not avoided, may result in minor or moderate injury.

Warnings

Warnings identify potentially dangerous situations or serious hazards. In this manual, a warning indicates an imminently hazardous situation which, if not avoided, could result in serious injury or death.

WARNING! Explosion hazard. Do not connect or disconnect equipment unless power has been switched off or the area is known to be non-hazardous.

Low Voltage Directive

For use in Installation Category II, Pollution Degree 2. If equipment is used in a manner not specified by manufacturer, protection provided by equipment may be impaired.

Notice of Copyright and Limitations

Copyright © 2002 by Magnetrol International.
All rights reserved.

Magnetrol reserves the right to make changes to the products described in this manual at any time without notice. Magnetrol makes no warranty with respect to the accuracy of the information in this manual.

Warranty

All Magnetrol/STI mechanical level and flow controls are warranted free of defects in materials or workmanship for five full years from the date of original factory shipment.

If returned within the warranty period; and, upon factory inspection of the control, the cause of the claim is determined to be covered under the warranty; then, Magnetrol will repair or replace the control at no cost to the purchaser (or owner) other than transportation.

Magnetrol/STI shall not be liable for misapplication, labor claims, direct or consequential damage or expense arising from the installation or use of equipment. There are no other warranties expressed or implied, except special written warranties covering some Magnetrol/STI products.

Quality assurance

The quality assurance system in place at Magnetrol/STI guarantees the highest level of quality throughout the company. Magnetrol/STI is committed to providing full customer satisfaction both in quality products and quality service.

Magnetrol's quality assurance system is registered to ISO 9001 affirming its commitment to known international quality standards providing the strongest assurance of product/service quality available.



Boiler Controls

External Cage Float Actuated Liquid Level Switches

Table of Contents

1.0 Installation		4.0 Preventive Maintenance	
1.1 Unpacking.....	1	4.1 What To Do – Every 6 Months.....	15
1.2 Critical Alarm Function	1	4.1.1 Switch Corrosion Inspection.....	15
1.3 Piping.....	1	4.1.2 Switch and Wiring Inspection	16
1.4 Shutoff Valves for Boiler Controls	2	4.1.3 Functional Test	17
1.5 Mounting	2	4.2 What To Do – Every 12 Months.....	18
1.6 Wiring.....	3	4.2.1 Switch Corrosion Inspection.....	18
2.0 Reference Information		4.2.2 Switch and Wiring Inspection	19
2.1 Description.....	4	4.2.3 Control Head Removal and Installation ...	20
2.2 Theory of Operation	4	4.2.4 Functional Test	22
2.3 Operating Cycle	5	5.0 Specifications	
2.4 Switch Differential Adjustment	5	5.1 Agency Approvals	23
2.4.1 Low Level Controls.....	6	5.2 Physical	24
2.4.1 High Level Controls	7	6.0 Replacement Parts	
2.5 Replacement of Standard Float and Stem Assembly	7	6.1 Standard Boiler Control Models.....	25
2.6 Replacement of Chamber Liner.....	9	6.1.1 Parts Identification.....	25
2.7 Tandem Float Models.....	11	6.1.2 Switch and Housing Reference	25
2.7.1 Installation, Preventive Maintenance, and Troubleshooting.....	11	6.1.3 Model B24, B25, C24, C25	26
2.7.2 Differential Adjustment	11	6.1.4 Model W24, W25, W29, W60	26
2.7.3 Replacement of Float and Stem Assembly.....	12	6.2 Tandem Boiler Control Models.....	27
3.0 Troubleshooting		6.2.1 Parts Identification.....	27
3.1 Check Switch Mechanism	13	6.2.2 Switch and Housing Reference	28
3.2 Check Sensing Unit.....	13	6.2.3 Model W24, W25, W29, W60	28
		7.0 Model Numbers	29

1.0 Installation

Caution: If equipment is used in a manner not specified by manufacturer, protection provided by equipment may be impaired.

1.1 Unpacking

Unpack the instrument carefully. Inspect all units for damage. Report any concealed damage to carrier within 24 hours. Check the contents against the packing slip and purchase order. Check and record the serial number for future reference when ordering parts.

Caution: Do not discard the shipping container until all parts are accounted for.

1.2 Critical alarm function

NOTE: Confirm that the installed unit meets the criteria of the intended application. The most critical parameters are the pressure, temperature, and specific gravity. If there is a question or conflict between actual parameters and the Magnetrol switch nameplate, contact Magnetrol for information on the level control (please have the serial number available).

It is recommended that for critical alarm functions, an additional level switch be installed as a high-high or low-low level alarm for maximum protection.

1.3 Piping

An instruction tag secured to the control gives dimensional data on switch actuating levels referenced from center line of upper side tank connection. Position control so that actuating levels correspond with the desired liquid level trip points in the boiler.

Caution: Refer to boiler manufacturer's specifications regarding control levels for piping alignment requirements.

Use pipe of sufficient strength to support the control. If necessary, provide a stand or hanger to help support its weight. All piping should be straight and free of "low spots" or "pockets" so that lower liquid line will drain towards the boiler and upper vapor line will drain toward the control.

Shut-off valves are recommended for installation between the boiler and the control. Refer to Figure 1. If control is to be used with a low temperature liquid (one which will "boil" in the float chamber if outside heat is absorbed),

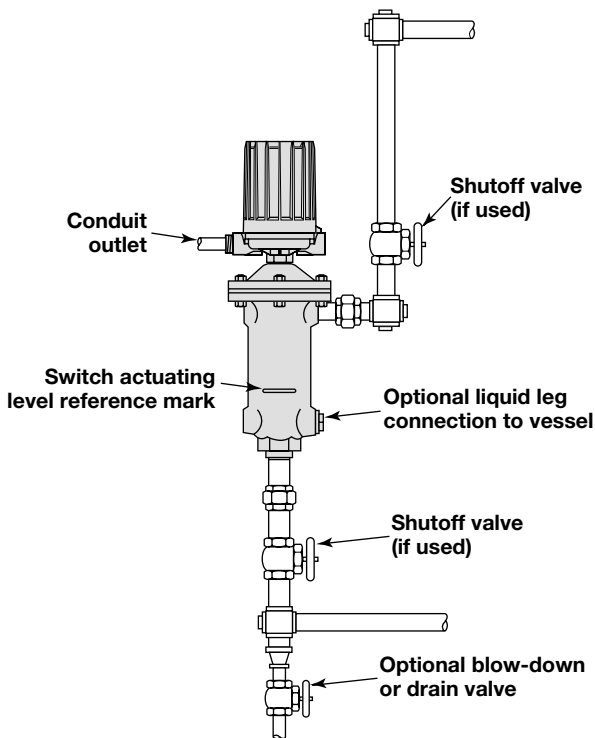

Figure 1
Typical Piping Arrangement

the chamber and piping should be insulated. Such boiling in the chamber will cause false level indications.

Caution: DO NOT INSULATE SWITCH MECHANISM HOUSING.

For controls equipped with pneumatic switch assemblies, consult bulletin on mechanism furnished for air (or gas) piping instructions. See *Switch and Housing Reference, Section 6.2.2.*

If the liquid to be controlled has a tendency to leave deposits in the piping, right angle turns should be made with cross type fittings equipped with plugs in unused openings. Removal of plugs will permit pipe line to be rodded clean. Blow-down connection on boiler installations should be piped in such a manner that the operator will not scald himself when blowing down control.

1.4 Shutoff Valves for Boiler Controls

When shutoffs are used in pipe connections between boiler and water column or boiler and shutoff valves (required for the gauge glass), they should be either outside-screw-and-yoke, level-lifting type gate valves, or stop cocks with levers permanently fastened; or another type through-flow shutoff valve that prevents blockage by sediment. Shutoff valves should be locked or sealed in the open position. When stop cocks are used, they should be the type with the plug held in place by a guard or gland.

1.5 Mounting

Caution: This instrument is intended for use in Installation Category II, Pollution Degree 2 locations.

Controls used on boiler applications should be mounted as close to the boiler as possible. This will result in a more responsive and accurate level change in the control. Water in a long line, will be cooler and more dense than the boiler water, causing lower level indication in the control than actual level in the boiler.

Adjust piping as required to bring control to a vertical position. Magnetrol controls must be mounted within three degrees (3°) of vertical in all directions. A three degree slant is noticeable by eye, but installation should be checked with a spirit level on top and/or sides of float chamber.

Caution: Never insulate the switch housing of the level control.

Installation and maintenance of tandem float models are accomplished in much the same manner as described for standard models. Additional consideration must be given to the piping arrangement to allow for alignment of the two switch actuating level marks on the float chamber with the desired levels in the vessel.

1.6 Wiring

Caution: All Boiler Controls are shipped from the factory with the enclosing tube tightened and the switch housing set screw locked to the enclosing tube. Failure to loosen the set screw prior to repositioning the conduit connections may cause the enclosing tube to loosen, resulting in possible leakage of the process liquid or vapor.

Boiler controls are shipped with the conduit entry of the switch housing placed 180° opposite the tank connections to simplify most installations. If this configuration is appropriate to the installation, proceed to Step 4 to begin wiring the unit. If another configuration is desired, the switch housing can be easily rotated by first following Steps 1, 2, and 3.

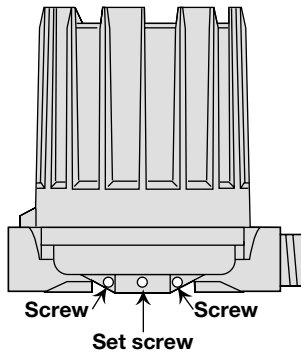

Figure 2
Switch Housing Base Set Screws

NOTE: A switch or circuit breaker shall be installed in close proximity to equipment and within easy reach of operator. It shall be marked as the disconnecting device for equipment.

1. Loosen set screw(s) at base of switch housing. Refer to Figure 2.
2. Switch housing may be rotated 360° to allow correct positioning of conduit outlet.
3. Tighten set screw(s) at base of switch housing.
4. Unscrew and remove switch housing cover. The threads have been lubricated to facilitate removal.

NOTE: For supply connections, use wire with a minimum rating of +167° F (+75° C) as required by process conditions. Use a minimum of 14 AWG wire for power and ground field wires.

NOTE: Housing must be grounded via protective ground screw in the base of the housing.

NOTE: On high temperature applications (above +250° F [+121° C] in float chamber), high temperature wire should be used between control and first junction box located in a cooler area. On non-hazardous applications, flexible conduit may be used between the control and the first junction box.

5. The switch terminals are located next to the conduit outlet to facilitate wiring. Bring supply wires through conduit outlet. Route extra wire around enclosing tube under the

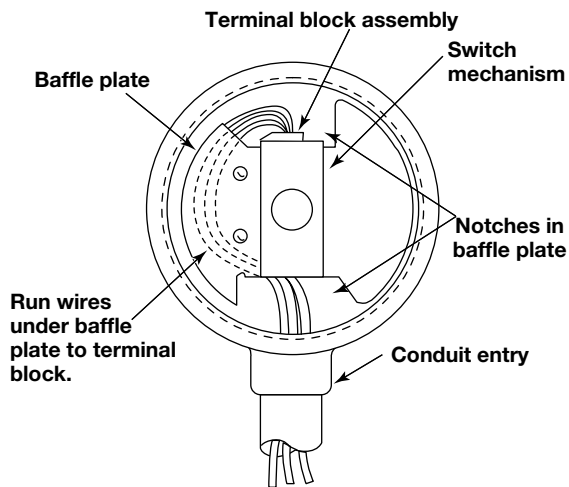

Figure 3
Placement of Supply Wires

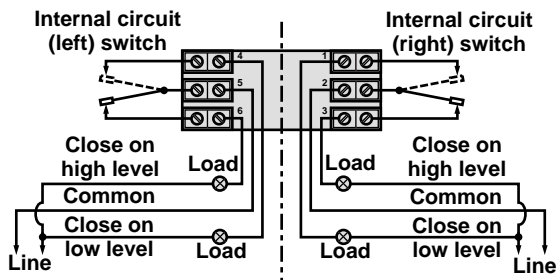

Figure 4
Terminal Connections
DPDT Switch Mechanism
Series A, B, C, D, and E

baffle plate. Refer to Figure 3. Connect the supply wires to the proper terminals. Refer to Figure 4 or your switch bulletin for this information. See *Switch and Housing Reference, Section 6.2.2*.

6. Dress wiring to ensure no interference or contact with tilt of switch, or replacement of switch housing cover.

NOTE: It is the responsibility of the customer to comply with applicable installation codes and practices. Class I, Division 1 locations may contain explosive gas mixtures. Appropriate precautions must be taken. Installation should be performed by qualified personnel.

7. Replace housing cover.

8. If control has been furnished with an explosion proof or moisture proof switch housing, it must be sealed at the conduit outlet with a suitable compound or non-hardening sealant to prevent entrance of air.

9. Test switch action by varying liquid level in float chamber.

NOTE: If switch mechanism fails to function properly, check vertical alignment of control housing and consult installation bulletin for additional wiring information on switch mechanism furnished. See *Switch and Housing Reference, Section 6.2.2*.

10. Check cover to base fit to be certain gasketed joint is tight. A positive seal is necessary to prevent infiltration of moisture laden air or corrosive gasses into switch housings.

Caution: In hazardous areas, do not power the unit until the conduit is sealed and the enclosure cover is screwed down securely.

2.0 Reference Information

2.1 Description

Boiler controls are completely self-contained units, designed for side mounting to a vessel or tank with threaded or flanged pipe connections.

2.2 Theory of Operation

The design of float operated level switches is based upon the principle that a magnetic field will not be affected by non-magnetic materials such as 316 stainless steel. In this case, the float moves a magnetic attraction sleeve within a non-magnetic enclosing tube and actuates a magnetic switch mechanism. The enclosing tube provides a pressure seal to the chamber and therefore to the process.

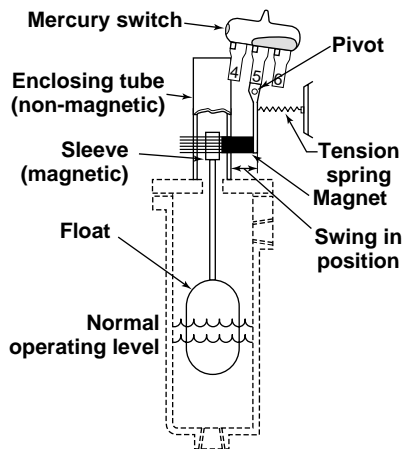

Figure 5
"Swing In" Magnet Position

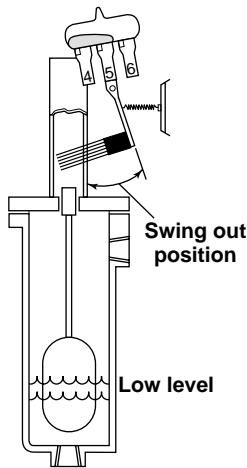

Figure 6
"Swing Out" Magnet Position

2.3 Operating Cycle

As the liquid level rises in the chamber the float moves the magnetic attraction sleeve up, within the enclosing tube and into the field of the switch mechanism magnet. As a result, the magnet is drawn in tightly to the enclosing tube, causing the switch to trip making or breaking an electrical circuit. Refer to Figure 5.

As the liquid level falls, the float drops and moves the attraction sleeve out of the magnetic field, releasing the switch mechanism magnet. The tension spring ensures the return of the switch in a snap action. Refer to Figure 6.

2.4 Switch Differential Adjustment

The standard differential of Boiler Control float models with one switch may be field adjusted. Adjustment may be necessary if a wider differential needs to be set to overcome switch chatter caused by the process.

NOTE: This procedure may be applied to single switch models only.

The differential, or the amount of level travel between switch-on and switch-off, may be adjusted by repositioning the lower jam nuts on the float stem. This adjustment is different for high level and low level controls. Please refer to the appropriate section below for adjustment instructions.

NOTE: Maximum differential adjustment is 1 inch.

Caution: Differential adjustments should NOT be made in the field on tandem float models. Switch actuation levels have been set at the factory to meet customer specifications. Variations in actual conditions from design conditions, usually require special control modifications. Consult the factory or your local representative for assistance.

2.4.1 Low level controls

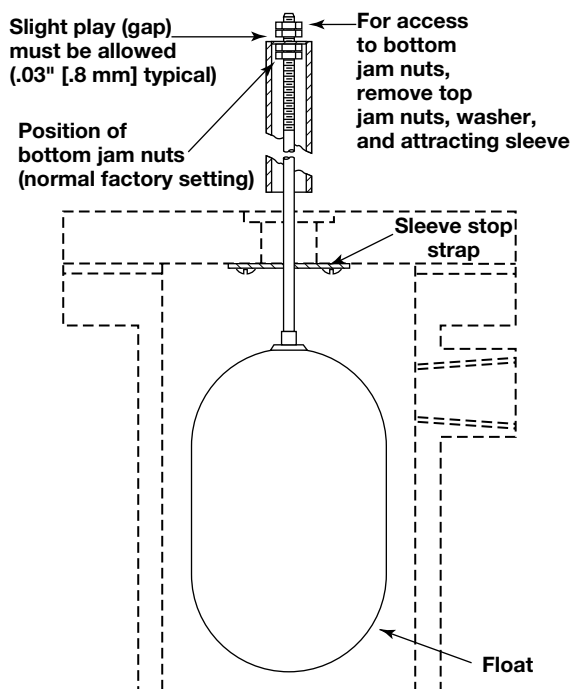

Figure 7
Normal Factory Setting
(minimum differential)

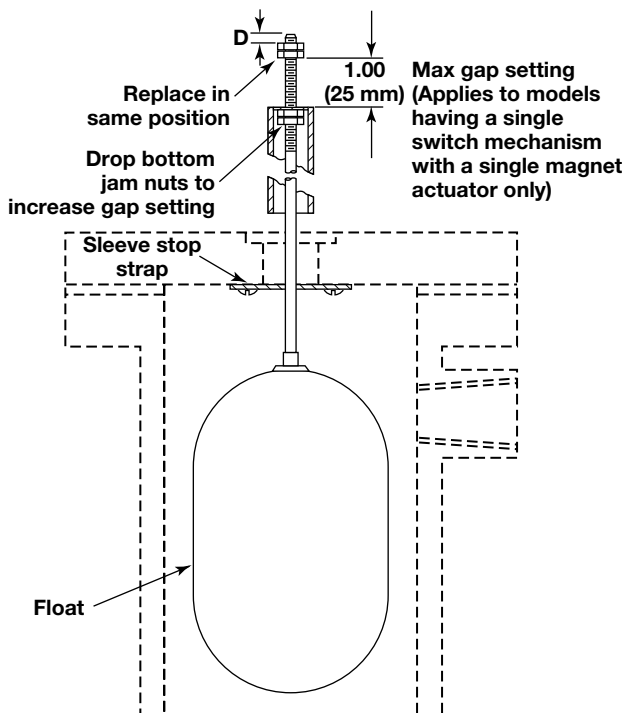

Figure 8
Differential Adjustment

On low level controls the switch trips on the lower actuation point and resets on the higher actuation point. Widening the differential will allow the switch to trip on the original actuation point and reset at a later or higher point.

The differential on low level controls may be adjusted by repositioning the lower jam nuts on the float stem. The standard factory setting is for a minimum amount of play (gap) between the top jam nuts and the attraction sleeve. Refer to Figure 7.

1. Determine what change in differential is necessary.
- NOTE: To widen the differential by one inch, the lower jam nuts must be set proportionately lower on the stem (i.e. in this example by 1 inch).
2. Make sure power source is turned off.
 3. Unscrew and remove switch housing cover.
 4. Disconnect power supply wires from switch mechanism. Pull wires out of conduit connection opening in housing base. Refer to Figure 9 on page 7.
 5. Perform system shut-down procedures as required to relieve pressure from float chamber of control. Allow unit to cool.
 6. Close shut-off valves (if so equipped) to isolate control from tank. Drain off liquid in float chamber.
 7. On installations without shut-off valves, relieve pressure from the tank. Drain liquid in tank to a level below the connections of the float chamber.
- NOTE: Level control, connections and pipe lines need not be removed from the tank.
8. Loosen enclosing tube nut with a $\frac{1}{16}$ " wrench. Unscrew enclosing tube counterclockwise (switch and housing base will rotate also), until it is free. Refer to Figure 9 on page 7.
 9. Lift enclosing tube, switch, and base off float chamber. Jam nuts and attraction sleeve are now accessible.
 10. Measure the distance "D" from the top edge of the upper jam nuts to the top of the float stem. Refer to Figure 8. Record this measurement.
 11. Loosen and remove upper jam nuts, guide washer and attraction sleeve.
 12. Loosen and adjust lower jam nuts to the desired position. Tighten lower jam nuts securely. Refer to Figure 8.
 13. Replace attraction sleeve on stem.

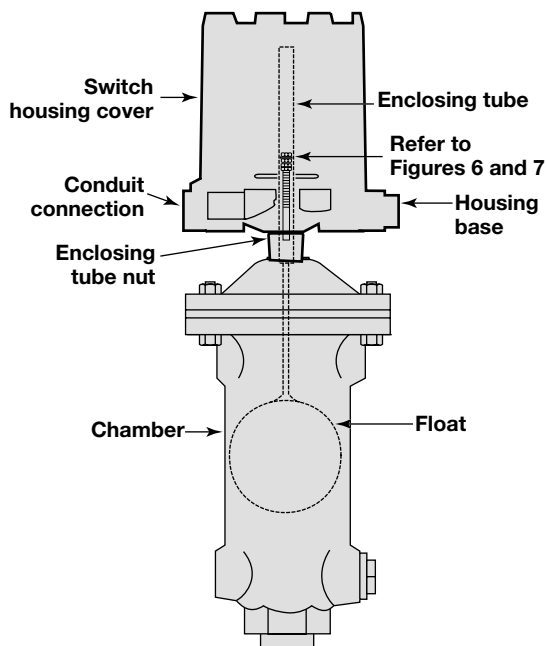

Figure 9

14. Replace upper jam nuts and guide washer on the stem in the position previously noted. Tighten upper jam nuts securely. Refer to Figure 8 on page 6.

NOTE: Use a new enclosing tube gasket when reassembling enclosing tube to the chamber. Make certain that all gasket surfaces are thoroughly cleaned to allow proper gasket seating. Coat enclosing tube threads with anti-seizing compound.

15. Replace enclosing tube, switch, and base on chamber. Rotate e-tube clockwise until tightened to 200–225 foot-pounds of torque.
16. Loosen the set screws at the base of the switch housing. Rotate switch housing to correct position and tighten set screws. Refer to Figure 2 on page 3.

Caution: After increasing gap setting, be certain to check for proper operation of switch mechanism by raising and lowering float assembly. Magnet must snap cleanly, with additional float movement available after magnet snaps.

17. Bring supply wires through conduit outlet. Follow Steps 5 through 10 in *Wiring, Section 1.6*.
18. Test switch action by varying liquid level in float chamber.

NOTE: If switch mechanism fails to function properly, check vertical alignment of control housing and consult installation bulletin on switch mechanism. If the unit still fails to function properly, consult the factory.

2.4.2 High level controls

On high level controls, the switch trips on the higher actuation point and resets on the lower actuation point.

Caution: On high level controls, widening the differential requires raising the trip point a proportional amount. The reset point will remain the same.

To widen the differential by raising the trip point, follow Steps 1 through 16 in *Low Level Controls, Section 2.4.1*.

2.5 Replacement of Standard Float and Stem Assembly

1. Disconnect wiring or medium lines from control and perform system shutdown. See *Low level controls, Section 2.4.1, steps 2 through 7*.
2. Remove switch housing assembly from float chamber at head flange by loosening flange bolting.

3. Remove sleeve stop strap from the underside of the head flange and slide the float stem assembly out of the enclosing tube.

NOTE: New float and stem kits are supplied unassembled. For standard jam nut settings (dimension A) refer to Figure 10 and Table 1.

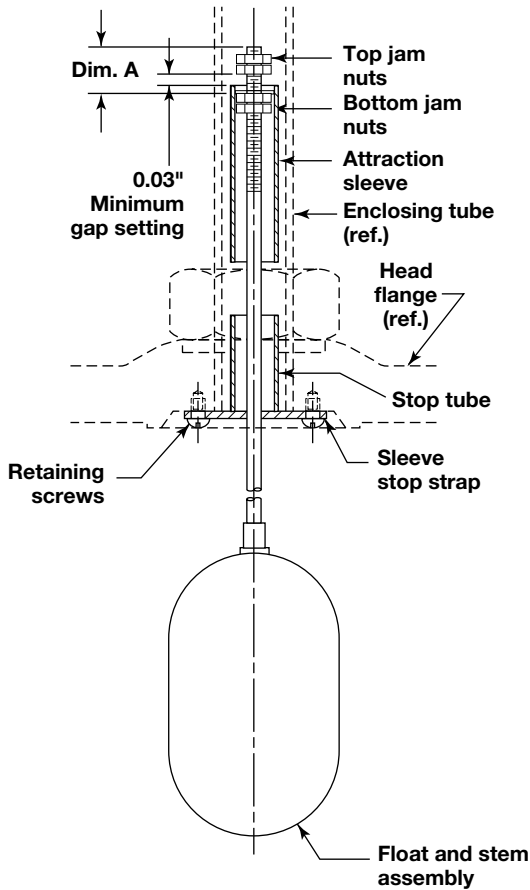

Figure 10

Table 1

Model	"A" Dimension
B24, C24	0.75 (19)
B25, C25 W24, W25, W29, W60	0.87 (22)

4. Check new float and stem assembly to be certain it is the correct replacement unit:
 - 4.1 Float should be of same physical size and shape.
 - 4.2 Stem length should match closely.
 - 4.3 Set attraction sleeve per dimension A as shown in Figure 10.

NOTE: If differential adjustment has been altered in the field, disregard dimension A and readjust new assembly to the previously determined level differential settings. See *Switch Differential Adjustment, Section 2.4*.

5. Replace new float and stem assembly into head flange and install new stop strap with screws included.
6. Remount head flange on float chamber, using new gasket provided. Tighten flange nuts evenly, using an alternating pattern typical of standard industry practice.

NOTE: Care must be taken during installation to be certain float stem does not become bent.

7. With control assembly in place, test switch actuation by varying liquid level in float chamber.

NOTE: When reassembling the enclosing tube or the upper flange assembly to the control, tighten according to the following torque values in Table 2.

Table 2

Model	Flange Bolting	Enclosing Tube
B24, B25, C24, C25 W24, W25, W29, W60	100-125 ft-lbs	200-225 ft-lbs

2.6 Replacement of Chamber Liner

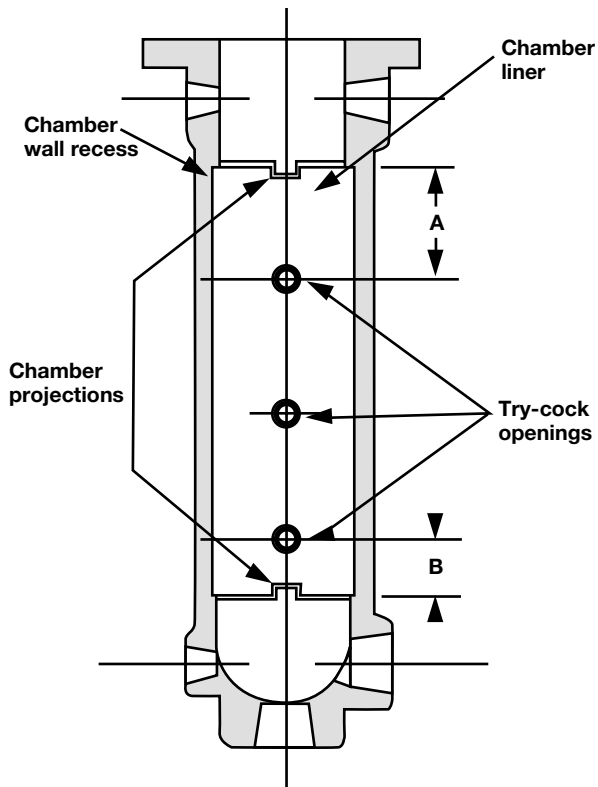

Figure 11
Chamber Liner Position

Models B24, B25, W24, and W25 cast float cage level controls, specified for boiler water service, are equipped with self-cleaning brass liners to prevent scale growth in the chambers. Since brass has a different coefficient of expansion than scale, any deposits that form will flake off the liners with temperature change and be removed during routine blow-down. Brass liners are designed to snap into a special recess provided in the wall of the chambers. Replacement liners are designed with a temper to spring out against chamber wall for secure positioning.

1. Perform system shut down as required to relieve pressure from float chamber of control and allow unit to cool.

Caution: Failure to disconnect electrical power to the unit during maintenance may result in shock or serious injury

2. Disconnect wiring from supply side of switch mechanism(s) and remove electrical conduit of operating medium line connections to switch housing.
3. Remove switch housing, along with float and stem assembly, by unbolting unit at head flange.

NOTE: Old liners are nearly always damaged during removal. Do not attempt to reuse old liner.

4. With old liner removed, scrape chamber walls thoroughly to remove all rust and scale deposits.

NOTE: New liner must fit snugly against chamber wall. Any foreign particles between new liner and chamber will prevent a good fit.

5. Check positioning of liner carefully before attempting to insert into chamber.
 - 5.1. Try-cock openings on certain water column models are equidistant from both top and bottom of recess in chamber wall, as indicated by reference dimensions A and B. Refer to Figure 11. If wrong end of liner is inserted first, try-cock openings will not line up with holes in liner.
 - 5.2. Liner should be rotated to correct position before inserting as it is best to avoid having to turn liner inside the chamber.

-
6. To install new liner, hold with both hands and carefully squeeze it to a diameter slightly less than the chamber opening, with edges overlapped slightly.
 7. When properly inserted, liner will spring out to fit into recess of chamber wall.
 8. Check edges of liner, which were overlapped during installation, to be certain they now butt firmly together over entire length of liner.
 9. Water column models have two projections into recess of chamber wall. Projections must engage in notches provided in top and bottom of liner to prevent rotation while in service.

Caution: Unless liner edges are butted entire length, holes aligned with chamber openings and ends engaged correctly in chamber wall recess, liner may prevent proper float operation or obstruct water flow.

10. Reassemble control and return to service in reverse order of steps 1 through 3. Refer to Table 2 on page 8 for flange bolting torque specifications.

2.7 Tandem Float Models

Models with tandem floats are used on applications where it is advantageous to have two widely spaced high and low switching functions using a single control.

The units incorporate two floats which operate independently, and are arranged so that the lower float actuates the upper switch mechanism, and the upper float actuates the lower switch mechanism. The upper float is attached to the lower attraction sleeve by means of a hollow stem. The lower float attaches to the upper attraction sleeve with a solid stem that extends upward, through the upper float and stem assembly.

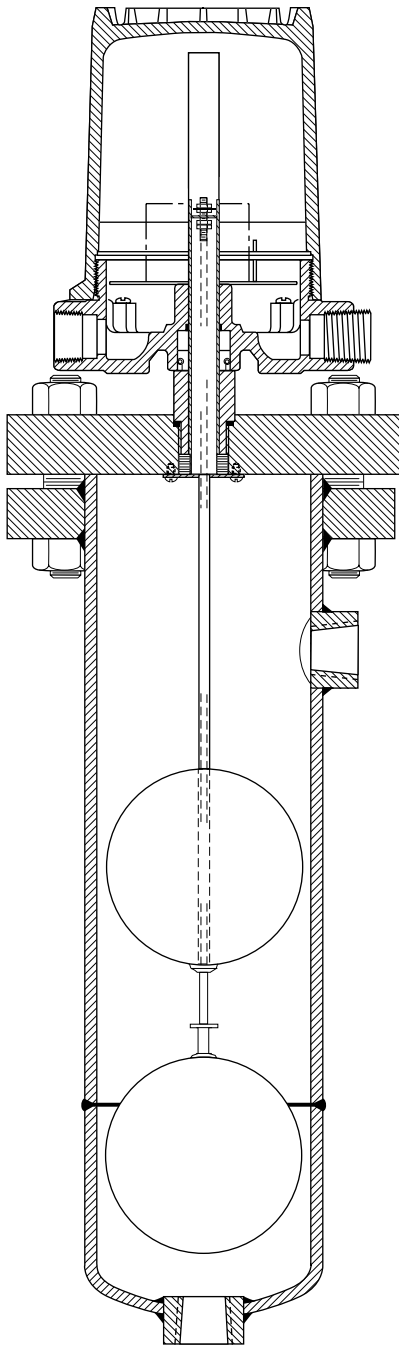

Figure 12
Typical Tandem Float Control

2.7.1 Installation, Preventive Maintenance, and Troubleshooting

Installation and maintenance of tandem float models is accomplished in much the same manner as for standard models previously described. Some additional consideration must be given to the piping arrangement to allow for alignment of the two switch actuating level marks on the float chamber with the desired levels in the vessel. When troubleshooting the level sensing portion of the control, additional checks may be made of the following:

1. Inspect for binding of solid (lower) float stem within hollow (upper) float stem due to corrosion or possible damage incurred during shipment or blowdown.
2. Make certain that retaining (snap) rings, used to locate lower attraction sleeve, are locked in place. An extreme shock or hammer, such as during blow-down on a water column boiler control, may damage a ring causing it to snap out of its retaining groove in the hollow (upper) float stem.

2.7.2 Differential Adjustment

Caution: No differential adjustment should be made on tandem float models in the field. Switch actuation levels have been set at the factory to meet customer specifications. Variations in actual conditions, from design conditions, usually require special control modifications.

2.7.3 Replacement of Float and Stem Assemblies

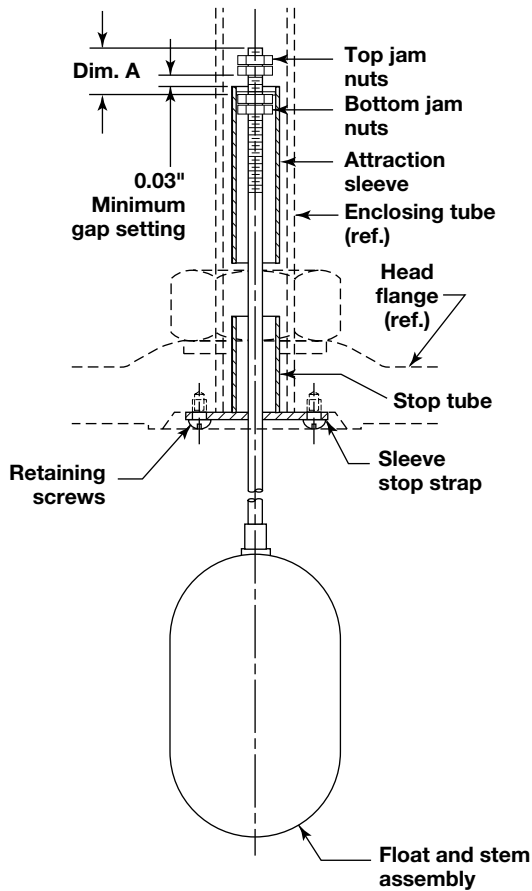

Figure 13

Should replacement of either upper or lower float and stem assembly be required, see *Replacement of Standard Float and Stem Assembly, Section 2.5.*

1. New float and stem assemblies are available in separate replacement kits with attraction sleeve parts furnished loose, to allow for field assembly with existing serviceable components. See *Replacement Parts, Section 6.0.*
2. Dimension A, shown in Figure 13 must be determined by direct measurement from old assembly.

NOTE: Disregard dimension A shown in Table 1 on page 8. If in doubt, or unable to get an accurate measurement from old assembly, consult factory or local representative for assistance.

3. Lower attraction sleeve locks in place on hollow (upper) float stem with external type snap rings.

NOTE: Care must be taken to be certain rings are properly installed. If available, use the correct type external snap ring pliers.

3.0 Troubleshooting

Usually the first indication of improper operation is failure of the controlled equipment to function, i.e.: pump will not start (or stop), signal lamps fail to light, etc. When these symptoms occur, whether at time of installation or during routine service thereafter, check the following potential external causes first.

- Fuses may be blown.
- Reset button(s) may need resetting.
- Power switch may be open.
- Controlled equipment may be faulty.
- Wiring leading to control may be defective.

If a thorough inspection of these possible conditions fails to locate the trouble, proceed next to a check of the control's switch mechanism.

3.1 Check Switch Mechanism

1. Pull switch or otherwise disconnect power to the control.
2. Remove switch housing cover.
3. Disconnect power wiring from switch assembly.
4. Swing magnet assembly in and out by hand to check carefully for any sign of binding. Assembly should require minimal force to move it through its full swing.
5. If binding exists, magnet may be rubbing enclosing tube. If magnet is rubbing, loosen magnet clamp screw and shift magnet position. Retighten magnet clamp screw.
6. If switch magnet assembly swings freely and mechanism still fails to actuate, check installation of control to be certain it is within the specified three (3°) degrees of vertical.
7. If mechanism is equipped with a mercury switch, examine glass mercury tube closely as described in *Preventive Maintenance, Section 4.1.1, step 3*. If switch is damaged, replace it immediately. If microswitch, check continuity with ohmmeter.
8. If switch mechanism is operating satisfactorily, proceed to check sensing unit.

NOTE: As a matter of good practice spare switches should be kept on hand at all times.

3.2 Check Sensing Unit

1. Reconnect power supply and carefully, manually actuate switch mechanism (use a non-conductive tool on electrical switch mechanisms) to determine whether controlled equipment will operate.

Caution: With electrical power on, care should be taken to avoid contact with switch leads and connections at terminal block.

2. If controlled equipment responds to manual actuation test, trouble may be located in the level sensing portion of the control, float(s), stem(s), and magnetic attraction sleeve(s).
3. Check to be certain liquid is entering float chamber. A valve may be closed or piping plugged.

Caution: Be certain to pull disconnect switch or otherwise ensure that electrical circuit(s) through control is deactivated. Close operating medium supply valve on controls equipped with pneumatic switch mechanisms.

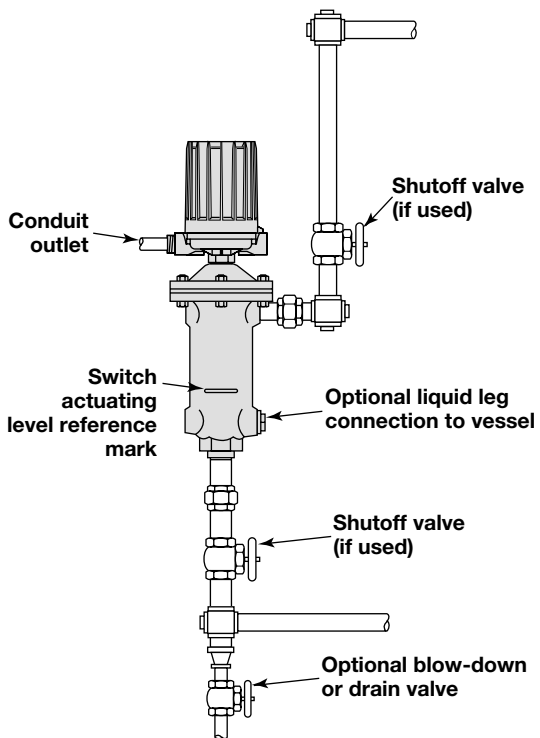

Figure 14

-
4. Disconnect wiring from supply side of switch mechanism(s) and remove electrical conduit or operating medium line connections to switch housing.
 5. Perform system shutdown to relieve pressure from float chamber of control, and allow unit to cool.
 6. Close shutoff valves (if equipped) to isolate control from vessel. Drain off liquid in chamber if necessary
 7. On installations without shutoff valves, relieve pressure from vessel and drain off liquid head above control mounting level.

NOTE: Control chamber, connections, and pipe lines need not be removed from vessel or boiler.

8. Remove switch housing assembly by loosening enclosing tube hex nut, which is located immediately below housing base. Refer to Figure 9 on page 7.
9. With switch housing assembly removed, inspect attraction sleeve(s) and inside of enclosing tube for excessive corrosion or solids buildup, which could restrict movement, preventing sleeve(s) from reaching field of switch magnet(s).
10. If differential has been changed in the field by repositioning the lower jam nuts on the float stem, check tightness and position of the jam nuts.
11. Check float to be certain it is buoyant in the liquid (float chamber or vessel must have adequate liquid level). If float is determined to be filled with liquid, or it is collapsed, it must be replaced immediately.

Caution: *Do not attempt to repair a float.* See *Replacement of Standard Float and Stem Assembly, Section 2.5.*

If all components in the control are in operating condition, the trouble must be (and should be) located external to the control. Repeat inspection of external conditions previously described.

NOTE: If difficulties are encountered which cannot be identified, consult the factory or your local representative for assistance. A complete description of the trouble should be provided along with information concerning your piping and mounting arrangement, plus a description of your operating sequence. Sketches or photographs showing the installation are also beneficial.

When communicating about your control, be certain to always specify the complete Model and Serial numbers.

4.0 Preventive Maintenance

Periodic inspections are a necessary means to keep your level control in good working order. This control is a safety device to protect the valuable equipment it serves.

Therefore, a systematic program of “preventive maintenance” must be implemented when the control is placed into service. If the following sections on “what to do” and “what to avoid” are observed, your control will provide reliable protection of your equipment for many years.

4.1 What to do — every 6 months (minimum)

4.1.1 Switch Corrosion Inspection

For every 6 months in service, conduct the following maintenance and inspection checks.

NOTE: For applications where the switches are exposed to corrosive environments this inspection should be conducted every 3 months.

Some environments may cause accelerated corrosion on the switch mechanism. In order to identify switch corrosion prior to failure, use the following procedures:

1. Disconnect power to the switch.
2. Remove switch housing cover to inspect switch mechanisms for visible signs of corrosion on terminals and wires.

NOTE: If cover is difficult to remove, secure base to prevent it from moving while loosening it. Loosen set screws securing the base to the enclosing tube prior to using a cross-bar or hammer to loosen cover. Loosening the set screws will prevent the enclosing tube from loosening resulting in possible leaks.

3. Mercury switches may be visually inspected for short circuit damage. Check for small cracks in the glass tube containing the mercury. Such cracks can allow entrance of air into the tube causing the mercury to oxidize. This is noticeable as the mercury will appear dirty or dull, and will not break into clean, round pools. If these conditions exist, replace the mercury switch immediately.
4. Dry contact switches should be inspected for excessive wear on actuating lever or misalignment of adjustment screw at point of contact between screw and lever. Such wear can cause false switch actuating levels. Adjust switch mechanism to compensate (if possible) or replace switch.

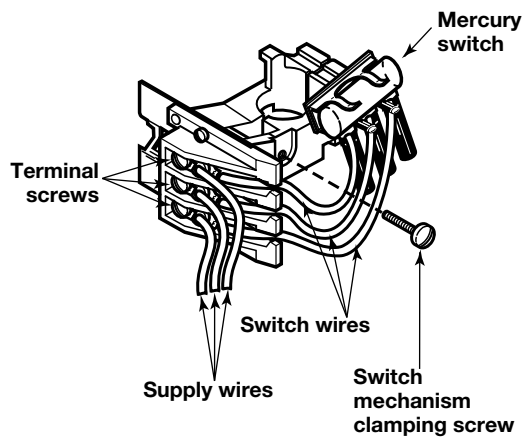

Figure 16

5. Controls may sometimes be exposed to excessive heat or moisture. Under such conditions, insulation on electrical wiring may become brittle, eventually breaking or peeling away. The resulting bare wires can cause short circuits. Check wiring carefully and replace at the first sign of brittle insulation.
6. Vibration may sometimes cause terminal screws to work loose. Check all terminal connections to be certain that screws are tight.
7. Conduct a continuity test for switch contacts, using a low voltage DC circuit with an indicator.
8. Switches that are corroded or that failed the contact continuity test should be replaced. DO NOT operate your control with defective or maladjusted switch mechanisms (refer to bulletin on switch mechanisms furnished for service instructions.)
9. Verify that switch housing cover and conduit seal are properly closed after each inspection of the switch mechanism(s).

NOTE: In applications with presence of salt laden air or corrosive vapors, contact Magnetrol for possible alternate switch mechanisms.

4.1.2 Switch and Wiring Inspection

The switch mechanism and supply wiring need to be in proper position to assure correct switch operation.

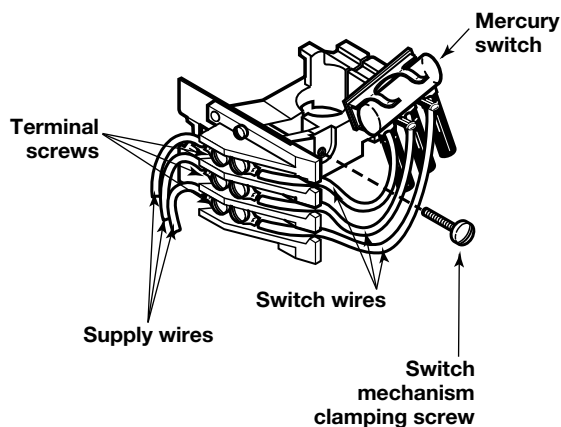

Figure 17

1. Remove switch housing cover to inspect the supply wires.
2. Check that the supply wires are attached to the terminal block and run under the baffle plate. Be certain that excess wire does not interfere with the tilt of the switch and that adequate clearance exists for replacement of switch housing cover.
3. Manually push on the magnet of the switch mechanism to confirm that the mechanism pivots freely. If it does not, the switch mechanism should be replaced.

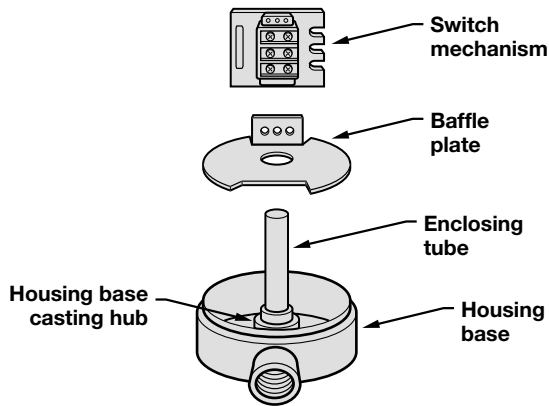

Figure 18

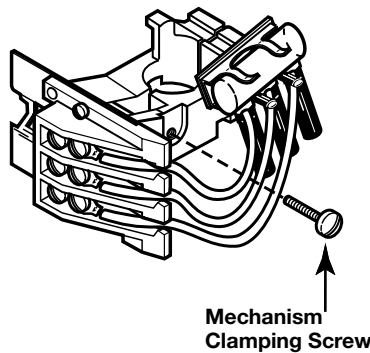

Figure 19

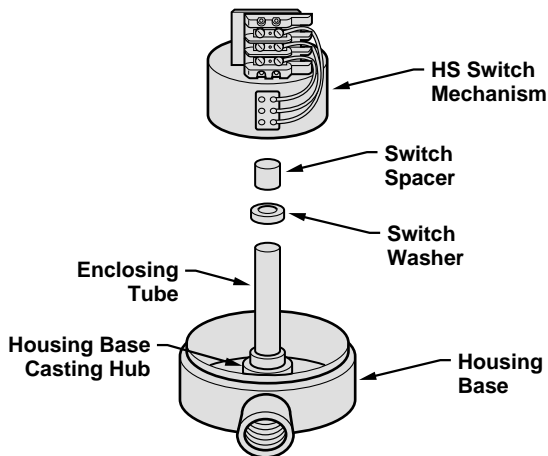

Figure 20

4. Make sure the switch mechanism is seated all the way down on the baffle plate. Refer to Figure 18. Additionally, check that the mechanism clamping screw is tightened to assure that the mechanism is secured to the enclosing tube and in proper position on the baffle plate. Refer to Figure 19. The baffle plate should rest on the housing base casting hub.

NOTE: HS series switches use a cylindrical spacer in place of the baffle plate. Refer to Figure 20.

5. If the above wiring conditions are not met the unit should be rewired. Proceed to step 6.

NOTE: When wiring units with mercury switches, care must be taken to ensure that the control wires do not interfere with the movement of the switch.

6. Disconnect power to the switch.
7. The baffle plate is notched at the front and rear for control wires to pass through. Control wires should enter through the conduit entry, pass under the baffle plate to the notch, then proceed through to the terminal block. Refer to Figure 3 on page 4.
8. Switch mechanism wires move as the switch pivots; control wires must not touch or interfere with mechanism wires. Refer to Figures 16 and 17 on page 16 for wiring with two different terminal block configurations.
9. Control wires should not touch moving parts in any way.
10. The control wires should be attached to the terminal block so that they run from the terminal block, down through the notch, and under the baffle plate.

NOTE: The control wires must not interfere with the switch mechanism wires.

11. Connect power supply to the control and conduct functional test of unit as described below.
12. Replace switch housing cover and place control into service.

4.1.3 Functional Test of Unit

This procedure will assure that the complete unit is functioning properly. This test should be conducted after switch and wiring inspections have been completed.

1. Adjust piping as required to bring control to a vertical position. Control must be mounted within 3° degrees of vertical. Installation should be checked with an indicating level on top or sides of float chamber.

-
2. Check the chamber mounting within 3° degrees of vertical after the boiler installation.
 3. Raise level in the vessel sufficient to raise the float and trip the switch. Lower level in the vessel sufficient to lower float and reset the switch. Confirm switch trips and resets at expected levels (contact Magnetrol for specific information on trip points; please have the serial number of the unit).

4.2 What to do — every 12 months (minimum)

4.2.1 Switch Corrosion Inspection

For every 12 months in service, conduct the following maintenance and inspection checks in addition to customer specific or code requirements.

NOTE: For applications where the switches are exposed to corrosive environments this inspection should be conducted every 3 months.

1. Disconnect power to the switch.
2. Remove switch housing cover to inspect switch mechanisms for visible signs of corrosion on terminals and wires.

NOTE: If cover is difficult to remove, secure base to prevent it from moving while loosening it. Loosen set screws securing the base to the enclosing tube prior to using a cross-bar or hammer to loosen cover. Loosening the set screws will prevent the enclosing tube from loosening resulting in possible leaks.

3. Mercury switches may be visually inspected for short circuit damage. Check for small cracks in the glass tube containing the mercury. Such cracks can allow entrance of air into the tube causing the mercury to oxidize. This is noticeable as the mercury will appear dirty or dull, and will not break into clean, round pools. If these conditions exist, replace the mercury switch immediately.
4. Dry contact switches should be inspected for excessive wear on actuating lever or misalignment of adjustment screw at point of contact between screw and lever. Such wear can cause false switch actuating levels. Adjust switch mechanism to compensate (if possible) or replace switch.

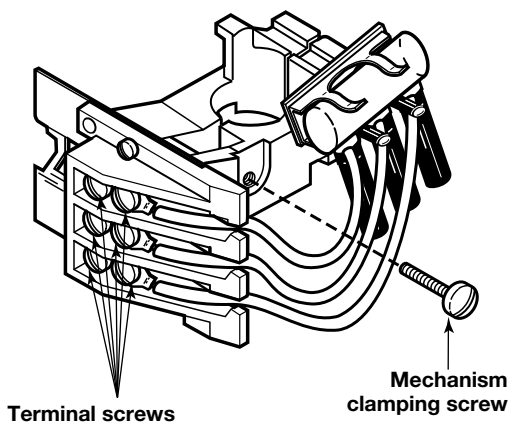

Figure 21

5. Controls may sometimes be exposed to excessive heat or moisture. Under such conditions, insulation on electrical wiring may become brittle, eventually breaking or peeling away. The resulting bare wires can cause short circuits. Check wiring carefully and replace at the first sign of brittle insulation.
6. Vibration may sometimes cause terminal screws to work loose. Check all terminal connections to be certain that screws are tight. Refer to Figure 21.
7. Conduct a continuity test for switch contacts, using a low voltage DC circuit with an indicator.
8. Switches that are corroded or that failed the contact continuity test should be replaced. DO NOT operate your control with defective or maladjusted switch mechanisms (refer to bulletin on switch mechanisms furnished for service instructions.)
9. Verify that switch housing cover and conduit seal are properly closed after each inspection of the switch mechanism(s).

NOTE: In applications with presence of salt laden air or corrosive vapors, contact Magnetrol for possible alternate switch mechanisms.

4.2.2 Switch and Wiring Inspection

The switch mechanism and supply wiring need to be in proper position to assure correct switch operation.

1. Remove switch housing cover to inspect the supply wires.
2. Check that the supply wires are attached to the terminal block and run under the baffle plate. Refer to Figure 3 on page 4. Be certain that excess wire does not interfere with the tilt of the switch and that adequate clearance exists for replacement of switch housing cover.
3. Manually push on the magnet of the switch mechanism to confirm that the mechanism pivots freely. If it does not, the switch mechanism should be replaced.
4. Make sure the switch mechanism is seated down on the baffle plate. Refer to Figure 18 on page 17. Additionally, check that the mechanism clamping screw is tightened to assure that the mechanism is secured to the enclosing tube and in proper position on the baffle plate. Refer to Figure 21. The baffle plate should rest on the housing base casting hub.

Note: HS series switches use a cylindrical spacer in place of the baffle plate. Refer to Figure 20.

- If the above wiring conditions are not met the unit should be rewired. Proceed to step 6.

NOTE: When wiring units with mercury switches, care must be taken to ensure that the control wires do not interfere with the movement of the switch.

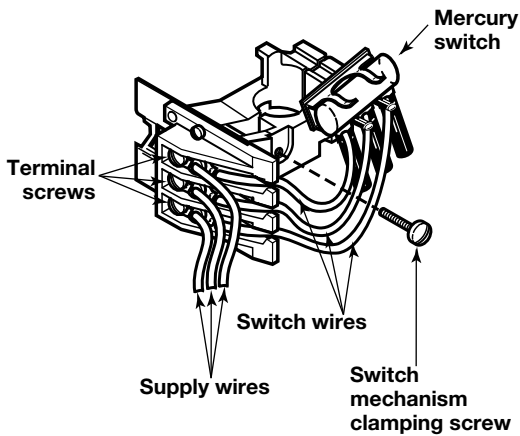

Figure 22

- Disconnect power to the switch.
- The baffle plate is notched at the front and rear for control wires to pass through. Control wires should enter through the conduit entry, pass under the baffle plate to the notch, then proceed through to the terminal block. Refer to Figure 3 on page 4.
- Switch mechanism wires move as the switch pivots; control wires must not touch or interfere with mechanism wires. Refer to Figures 22 and 23.
- Control wires should not touch moving parts in any way.
- The control wires should be attached to the terminal block so that they run from the terminal block, down through the notch, and under the baffle plate.

NOTE: The control wires must not interfere with the switch mechanism wires.

- Connect power supply to the control and conduct functional test of unit as described below.
- Replace switch housing cover and place control into service.

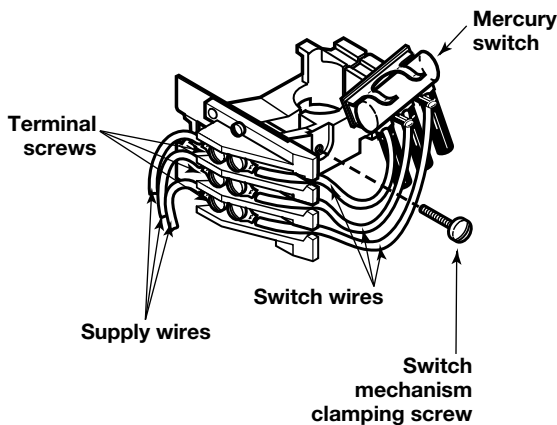

Figure 23

4.2.3 Control Head Removal and Installation

When inspection of the chamber is required the control head must be removed to provide proper access to the chamber. This procedure will assure that the head assembly is removed and reinstalled properly.

- Allow vessel to get to safe temperature and pressure before opening the pressure boundary.
- Power down all wiring to the unit.
- Remove all wiring and conduit from the unit.
- Remove flange bolts.

5. Prepare an area where the head assembly can be placed such that it rests on the flange in its normal orientation (two 2x4 boards placed across an open drum work well). Refer to Figure 24.
6. Carefully lift the head assembly by holding the sides of the flange. Maintain the head assembly as much as possible in the vertical position.

NOTE: Care must be taken not to place side force on the float which could bend the stem.

7. With the unit resting in its temporary fixture in an upright position, it can now be inspected or repaired.

Caution: *Do not* place the unit on its side — this could result in damage to the stem.

8. Conduct a check for float stem straightness as follows:
 - 8.1 Remove the stem assembly including attraction sleeve from the head assembly by removing the two screws holding the stop strap to the bottom of the flange. Refer to Figure 13 on page 12 for assembly schematic.
 - 8.2 Check the stem straightness by aligning the stem against a straight edge. Stems that are bent in excess of 1/8 inch over any 6 inch length should not be used in this condition. Replace any bent stems. See *Replacement Parts, Section 6.0.*

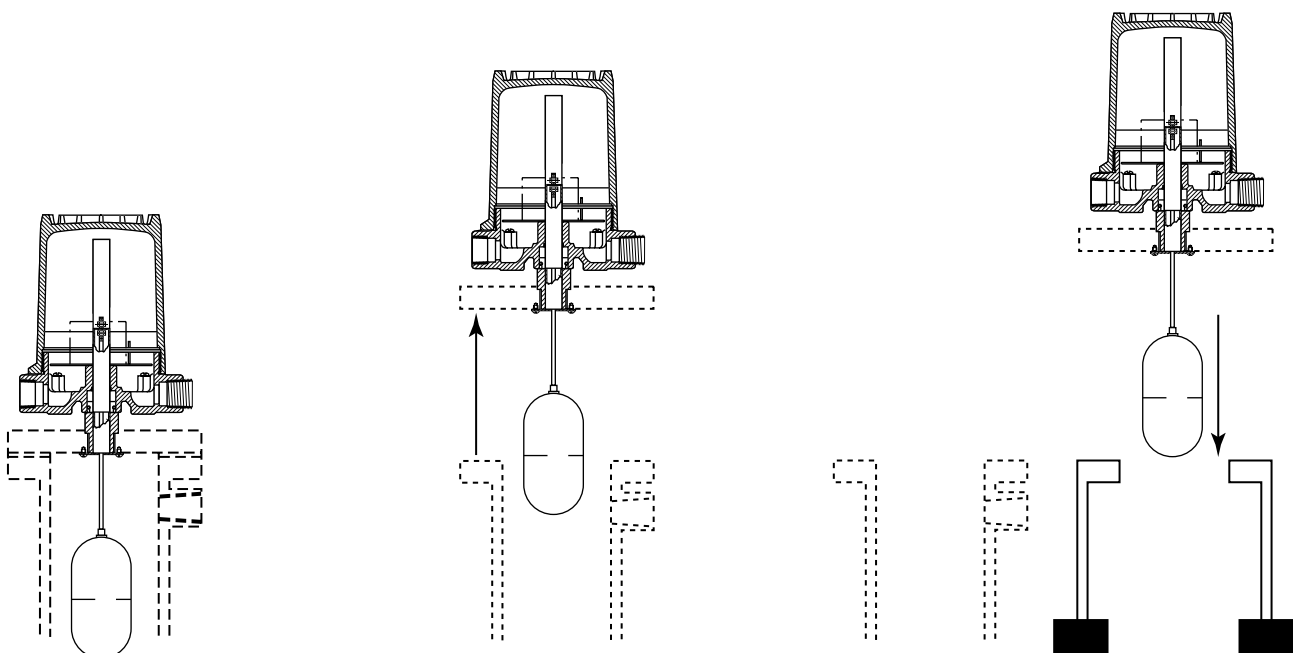

Figure 24

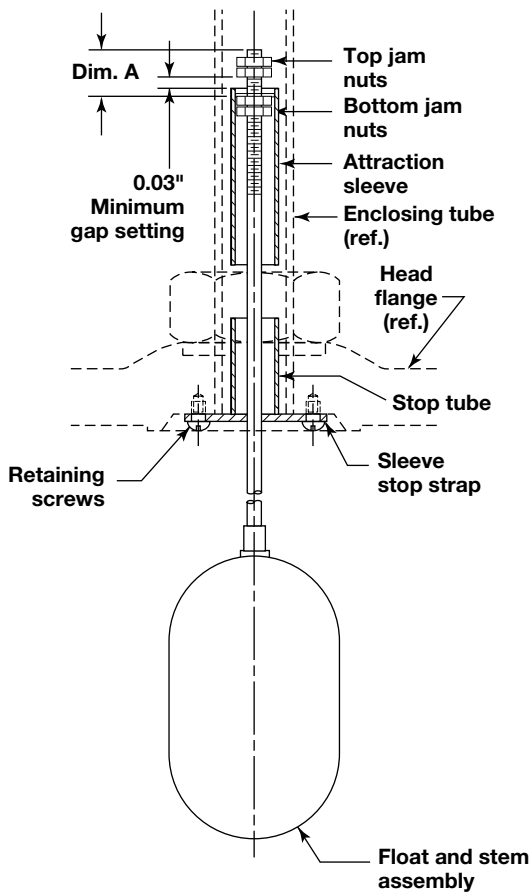

Figure 25

8.3 Ensure that the components in the stem assembly are in good condition and surfaces are clear of potential obstructions. The stem assembly is reinstalled by securing the stop strap to the flange. Ensure that the attraction sleeve moves freely through the enclosing tube and that the stem assembly surfaces are smooth.

Note: Care must be taken during the straightness check to be certain that the attraction sleeve is not removed from the stem and jam nuts settings are not changed.

9. Raise the liquid level in the container that the unit is set on sufficient to lift the float and trip the switch mechanism. Inspect inside of chamber for any obstructions or scale build up. If excessive build up is present, the interval between inspections should be shortened. Remove old gasket such that mating flange surfaces are completely clean. Position new gasket on chamber flange before replacing the head assembly.

Note: The float is restricted from moving laterally by the chamber, in the test configuration the float and stem can move further off center than possible under normal operation. Avoid excess movement in this lateral direction during the test. If switch trips, the unit may be reassembled. If not, follow the procedure in *Troubleshooting, Section 3.0*.

10. Replace the assembly keeping it as vertical as possible. Carefully lower the assembly into the chamber making sure that the stem does not become bent during installation. Refer to Figure 24.

11. Tighten flange bolts per torque values in Table 2 on page 8.

12. Attach wiring and connect power supply as described in *Switch and Wiring Inspection, Section 4.2.2*.





4.2.4 Functional Test of Unit

This procedure will assure that the complete unit is functioning properly. This test should be conducted after switch and wiring inspections have been completed.

1. Adjust piping as required to bring control to a vertical position. Control must be mounted within 3° degrees of vertical. Installation should be checked with an indicating level on top or sides of float chamber.
2. Check the chamber mounting within 3° degrees of vertical after the boiler installation.
3. Raise level in the vessel sufficient to raise the float and trip the switch. Lower level in the vessel sufficient to lower float and reset the switch. Confirm switch trips and resets at expected levels (contact Magnetrol for specific information on trip points; please have the serial number of the unit).

5.0 Specifications

5.1 Agency Approvals

AGENCY	MODEL APPROVED	APPROVAL CLASSES
FM 	All with an electric switch mechanism and a housing listed as NEMA 4X/7/9	Class I, Div 1, Groups C & D Class II, Div 1, Groups E, F & G
	All with an electric switch mechanism and a housing listed as NEMA 4X/7/9 Class I, Div 1, Group B	Class I, Div 1, Groups B, C & D Class II, Div 1, Groups E, F & G
CSA 	All with a Series HS, H1, 2 or 3 electric switch mechanism and a housing listed as CSA TYPE 4X	Class I, Div 2, Groups B, C & D
	All with an electric switch mechanism and a housing listed as NEMA 4X/7/9	Class I, Div 1, Groups C & D Class II, Div 1, Groups E, F & G
	All with an electric switch mechanism and a housing listed as NEMA 4X/7/9 Class I, Div 1, Group B	Class I, Div 1, Groups B, C & D Class II, Div 1, Groups E, F & G
CENELEC 	All with an electric switch mechanism and a CENELEC housing	EEx d IIC T6
SAA	All with an electric switch mechanism and a housing listed as NEMA 4X/7/9 Class I, Div 1, Group B	Ex d IIC T6 IP65
CE 	Low Voltage Directives 73/23/EEC & 93/68/EEC Per Harmonized Standard: EN 61010-1/1993 & Amendment No. 1	Installation Category II Pollution Degree 2

5.2 Physical

Inches (mm)

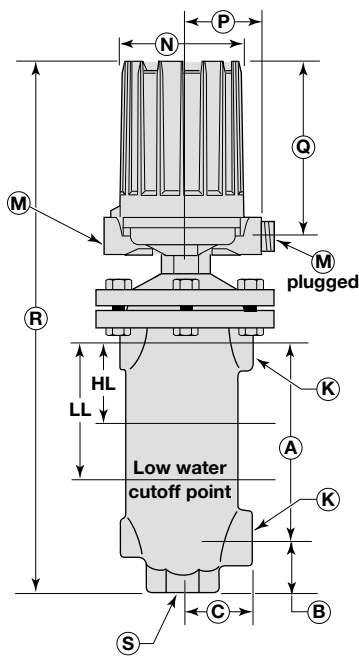

Models B25, C25

Allow 10.00 (254) overhead clearance for cover removal.

Conduit Connections M

Electrical Switches:
NEMA 4X/7/9: 1" NPT
Group B: 1" NPT
Pneumatic Switches:
NEMA 1: ¼" NPT

All housings rotatable 360°

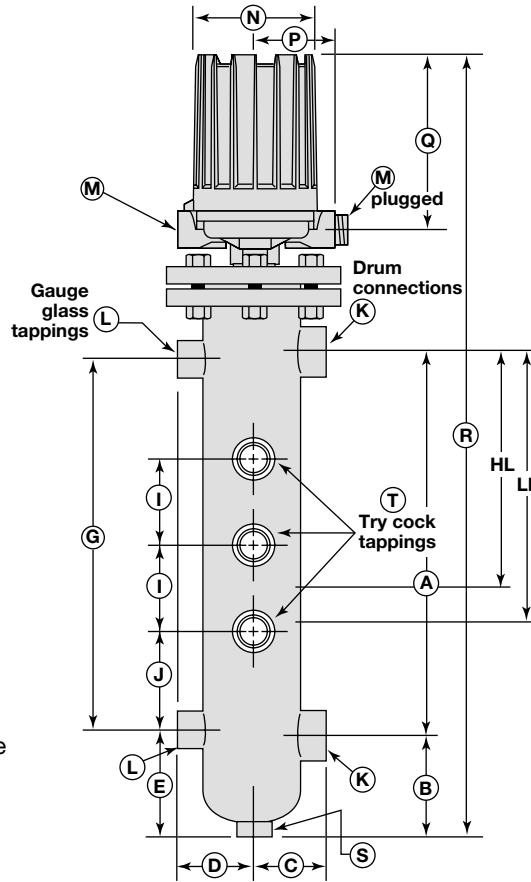

Models W24, W25, W29, W60

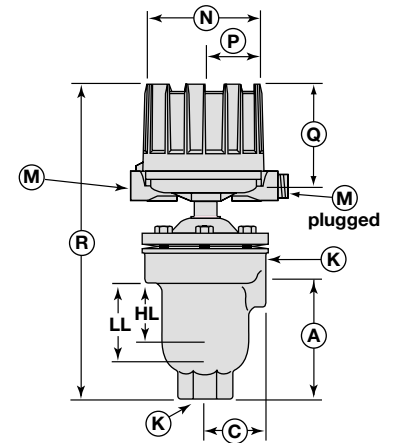

Models B24, C24

ACTUATION LEVELS *

Model	Min. S.G.		1.0	
	HL	LL	HL	LL
B24/C24	0.69 (18)	1.56 (40)	0.94 (24)	1.69 (42)
B25/C25	3.69 (94)	4.50 (114)	4.13 (105)	4.88 (124)
W24	11.38 (289)	12.25 (311)	11.88 (302)	12.63 (321)
W25	9.44 (240)	10.25 (260)	9.88 (251)	10.63 (270)
W29	11.00 (279)	11.88 (302)	11.50 (292)	12.25 (311)
W60	10.50 (267)	11.06 (281)	11.19 (284)	11.69 (297)

* Single switch mechanism only. Consult factory for multiple switches.

DIMENSIONS

Model	A	B	C	D	E	G	I	J	K	L	N	P	Q	R	S	T
B24/C24	5.56 (141)	n/a	2.81 (71)	n/a	n/a	n/a	n/a	n/a	1" NPT	n/a	5.93 (150)	3.78 (96)	6.25 (158)	16.25 (412)	n/a	n/a
B25/C25	7.00 (177)	2.00 (51)	2.63 (66)	n/a	n/a	n/a	n/a	n/a	1" NPT	n/a	5.93 (150)	3.78 (96)	8.46 (214)	22.12 (561)	1½" NPT	n/a
W24	16.00 (405)	3.00 (76)	2.63 (66)	3.06 (77)	3.50 (88)	15.00 (381)	3.50 (88)	4.00 (101)	1¼" NPT	¾" NPT	5.93 (150)	3.78 (96)	8.46 (214)	33.50 (850)	¾" NPT	¾" NPT
W25	13.50 (343)	2.00 (51)	2.63 (66)	3.06 (77)	2.00 (51)	13.50 (343)	3.00 (76)	3.00 (76)	1" NPT	½" NPT	5.93 (150)	3.78 (96)	8.46 (214)	28.62 (726)	1¼" NPT	½" NPT
W29	15.00 (381)	4.50 (114)	2.83 (71)	2.88 (73)	4.50 (114)	15.00 (381)	3.50 (88)	4.00 (101)	1¼" NPT	¾" NPT	5.93 (150)	3.78 (96)	8.46 (214)	33.50 (850)	¾" NPT	¾" NPT
W60 ①	15.00 (381)	4.19 (106)	3.61 (91)	3.66 (92)	4.19 (106)	15.00 (381)	3.50 (88)	4.00 (101)	1¼" NPT	¾" NPT	5.93 (150)	3.78 (96)	8.46 (214)	34.37 (872)	¾" NPT	¾" NPT

① Model W60 also available per customer specifications

6.0 Replacement Parts

6.1 Standard Boiler Control Models

6.1.1 Parts Identification

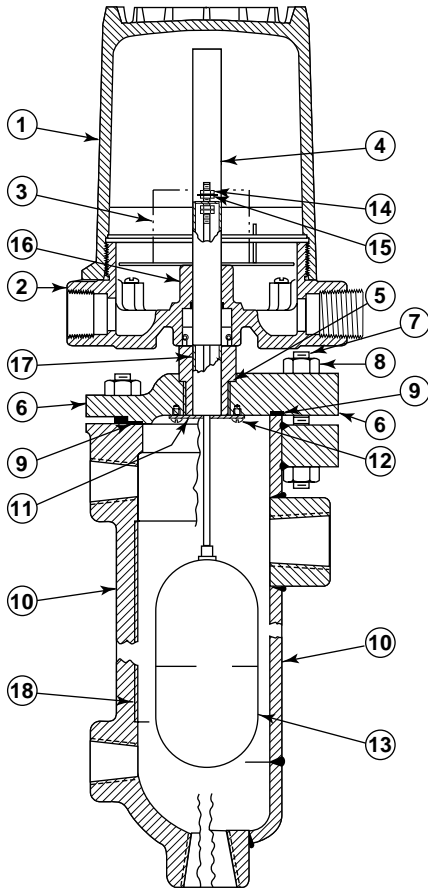

1	Housing cover
2	Housing base
3	Switch mechanism
4	Enclosing tube
5	Enclosing tube gasket
6	Head flange
7	Studs and bolts
8	Hex nuts
9	Flange gasket
10	Float chamber
11	Stop strap
12	Screws
13	Float and stem assembly
14	Jam nuts
15	Guide washer
16	Attraction sleeve
17	Stop tube
18	Chamber liner

IMPORTANT:

When ordering, please specify:

- A. Model and serial number of control.
- B. Replacement assembly (kit) part number.

6.1.2 Switch and housing reference

	Series Type	Bulletin#
Mercury	A	42-683
Anti-vibration mercury	E	42-683
Dry contact	B, C, D	42-683
Hermetically sealed	F	42-683
Hermetically sealed	HS	42-694
Bleed type pneumatic	J	42-685
Non-bleed type pneumatic	K	42-686

6.1.3 Models B24, C24, B25, and C25 ^①

	B24 ^②	C24	B25 ^②	C25 ^③
Housing cover	See at left		See at left	
Housing base	See at left		See at left	
Switch mechanism	See at left		See at left	
Enclosing tube kit	089-5933-001		089-5933-004 ^③	
includes items 4 and 5				
Enclosing tube gasket	012-1204-001		012-1204-001	
Head flange kit	089-4201-001		089-4202-001	
includes items 5, 6, 7, 8, and 9				
Flange gasket	012-1301-003		012-1301-003	
Float chamber kit ^②	089-4601-001		089-4602-002	089-4602-001
includes items 7, 8, 9, 10, and 18				
Float and stem assembly ^④	089-3201-001		089-3245-001	089-3202-001 ^③
includes items 9, 11, 12, 13, 14, 15, 16, and 17				
Chamber liner ^②	005-5524-001	not required	005-5518-001	not required
Complete control	089-6564-003 ^④		089-6565-004 ^⑤	089-6565-003 ^{③④}
less float chamber (10), bolts (7), nuts (8), and liner (18)				

6.1.4 Models W24, W25, W29 and W60

	W24 ^②	W25 ^②	W29	W60
Housing cover	See at left		See at left	
Housing base	See at left		See at left	
Switch mechanism	See at left		See at left	
Enclosing tube kit	089-5933-004		089-5933-004	
includes items 4 and 5				
Enclosing tube gasket	012-1204-001		012-1204-001	
Head flange kit	089-4202-001		089-4203-001	089-4206-002
includes items 5, 6, 7, 8, and 9				
Flange gasket	012-1301-003		012-1301-025	012-1301-024
Float chamber kit ^②	089-4608-001	089-4607-001	089-4609-001	089-4610-001
includes items 7, 8, 9, 10, and 18				
Float and stem assembly	089-3211-001	089-3210-001	089-3212-001	089-3213-001
includes items 9, 11, 12, 13, 14, 15, 16, and 17				
Chamber liner ^②	005-5520-001	005-5522-001	not required	
Complete control	089-6566-005 ^⑤	089-6566-004 ^⑤	089-6566-006 ^⑤	not available
less float chamber (10), bolts (7), nuts (8), and liner (18)				

Notes:

- ① All replacement assemblies listed are furnished in kit form for standard base models. Consult local representative for ordering assistance on all special model replacement parts or accessories not included in above listing. Model and serial numbers required.
- ② Cast float cage models used on boiler service require brass chamber liner.
- ③ Consult factory for replacement parts for models with material of construction code -2.
- ④ Furnished with one Series 3 SPDT mercury switch and standard switch housing.
- ⑤ Furnished with two Series 3 SPDT mercury switch and standard switch housing.

6.2 Tandem Boiler Control Models

6.2.1 Parts Identification

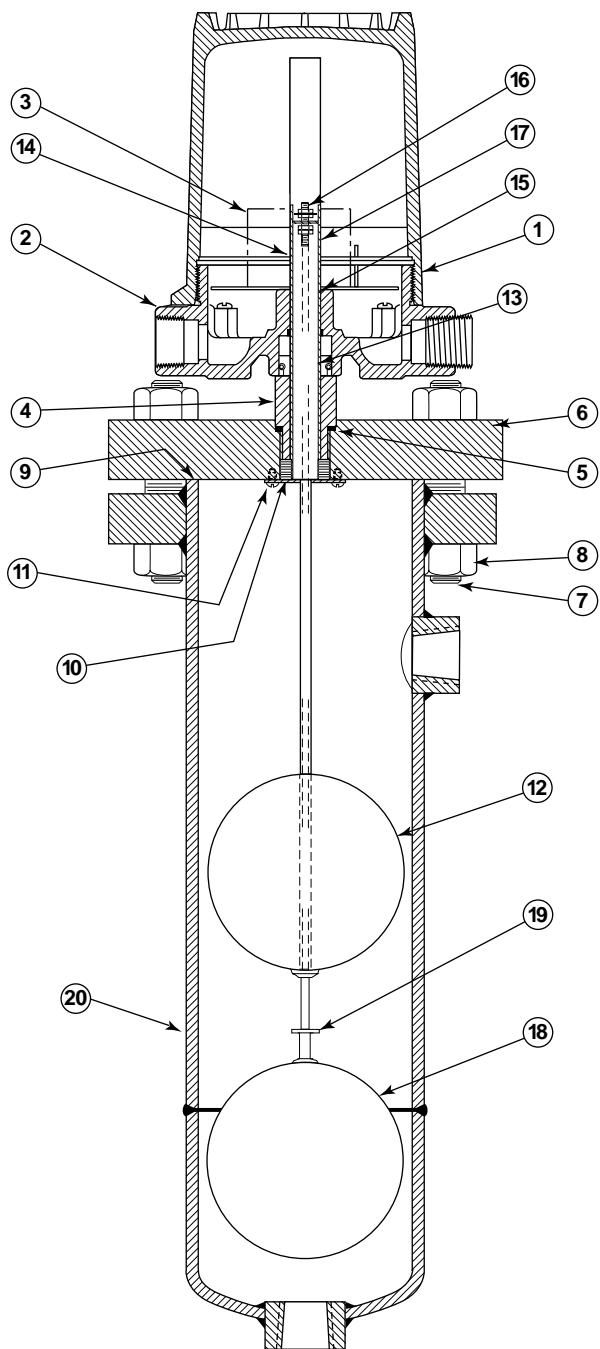

1	Housing cover
2	Housing base
3	Switch mechanism
4	Enclosing tube
5	Enclosing tube gasket
6	Head flange
7	Studs and bolts
8	Hex nuts
9	Flange gasket
10	Stop strap
11	Screws
12	Upper float and stem assembly
13	Lower attraction sleeve
14	Spacer washer
15	Retaining ring
16	Jam nuts
17	Upper attraction sleeve
18	Lower float and stem assembly
19	Safety stop washer
20	Float chamber
21	Chamber liner (not shown)

IMPORTANT:

When ordering, please specify:

- A. Model and serial number of control.
- B. Replacement assembly (kit) part number.

6.2.2 Switch and housing reference

	Series Type	Bulletin#
Mercury	A	42-683
Anti-vibration mercury	E	42-683
Dry contact	B, C, D	42-683
Hermetically sealed	F	42-683
Hermetically sealed	HS	42-694
Bleed type pneumatic	J	42-685
Non-bleed type pneumatic	K	42-686

6.2.3 Models W24, W25, W29 and W60

	W24 ^②	W25 ^②	W29	W60
Housing cover	See above		See above	
Housing base	See above		See above	
Switch mechanism	See above		See above	
Enclosing tube kit ^② ^④ includes items 4 and 5	089-5909-001		0089-5909-001	089-5933-004
Enclosing tube gasket	012-1204-001		012-1204-001	
Head flange kit includes items 5, 6, 7, 8, and 9	089-4202-001		089-4203-001	089-4206-002
Flange gasket	012-1301-003		012-1301-025	012-1301-024
Float chamber kit includes items 7, 8, 9, 20, and 21	089-4608-001	089-4607-001	089-4609-001	089-4610-001
Upper float and stem assembly ^④ includes items 9, 10, 11, 12, 13, 14, and 15	089-3225-001	089-3224-001	089-3217-001	see note ^③
Lower float and stem assembly ^④ includes items 9, 16, 17, 18, and 19	089-3214-001		089-3216-001	see note ^③
Chamber liner	005-5520-001	005-5522-001	not required	

Notes:

- ① All replacement assemblies listed are furnished in kit form for standard base models. Consult local representative for ordering assistance on all special model replacement parts or accessories not included in above listing. Model and serial numbers required.
- ② Cast float cage models used on boiler service require brass chamber liner.
- ③ Special order item. Specify model and serial number when ordering.

7.0 Model Numbers

MODEL NUMBER CODE, MATERIALS OF CONSTRUCTION AND TANK CONNECTION

Model Code	Minimum S.G.	Maximum WSP ^②	Chamber Material	Attraction Sleeve	Float Material	Trim Material	Max. WSP Rating	Max. Pressure @ 100° F (38° C)	Try Cock Mounting
B24-1B10 ^③	0.85	250 psig	Cast Iron ^①	400 Series SS	316L SS	316 SS	250 psi @ 406° F (17 bar @ 207° C)	400 psi (28 bar)	N/A
C24-1B10 ^④									
B25-1B10 ^③	0.84	250 psig	Cast Iron ^①	316 SS	316L SS	316 SS	250 psi @ 406° F (17 bar @ 207° C)	400 psi (28 bar)	
C25-1B10 ^④									
C25-2B10 ^④	0.84	250 psig	Cast Iron ^①	400 Series SS	316L SS	316 SS	250 psi @ 406° F (17 bar @ 207° C)	400 psi (28 bar)	Right Hand
W24-1B10 ^③	0.84	250 psig	Cast Iron ^①	400 Series SS	316L SS	316 SS	250 psi @ 406° F (17 bar @ 207° C)	400 psi (28 bar)	Right Hand
W25-1B10 ^③									
W29-1B10	0.84	300 psig	Fabricated Steel	400 Series SS	316L SS	316 SS	300 psi @ 422° F (21 bar @ 217° C)	500 psi (34 bar)	Left Hand
W60-1B10	0.75	600 psig					600 psi @ 489° F (41 bar @ 254° C)	900 psi (62 bar)	

ELECTRIC SWITCH MECHANISM AND ENCLOSURE^⑦

Switch Description ^⑧	Max. Process Temp. ° F (° C) ^⑤	Contacts	Set Points	B24 & C24 only	
				NEMA 4X/7/9 Aluminum Enclosure ^⑥	
				Class I, Div. 1, Groups C & D	Class I, Div. 1, Group B
Series 3 Mercury Switch w/Beaded Leads	750 (399)	SPDT	1	3KP	3KT
		DPDT	1	3NP	3NT
Series B Snap Switch	250 (121)	SPDT	1	BKP	BKT
		DPDT	1	BNP	BNT
Series C Snap Switch	450 (232)	SPDT	1	CKP	CKT
		DPDT	1	CNP	CNT
Series 2 Vibration Resistant Mercury Switch w/Beaded Leads	750 (399)	SPDT	1	2KP	2KT
		DPDT	1	2NP	2NT

- ① Cast iron models limited to maximum service temperature of +406° F (+207° C) or switch mechanism temperature rating if lower.
- ② Saturated steam service rating
- ③ Models B24, B25, W24, and W25 contain brass inner liners.
- ④ Models C24 & C25 are intended for non-boiler service as they do not contain a chamber liner.
- ⑤ Process temperature based on +100° F (+38° C) ambient
- ⑥ Uncontrolled housing heater or drain available in NEMA 4X/7/9. Consult factory for standard part numbers.
- ⑦ Consult factory for NEMA 4X/7/9 cast iron housings.
- ⑧ Consult factory for manual reset switches.



ELECTRIC SWITCH MECHANISM AND ENCLOSURE ⑦

Switch Description ⑧	Max. ⑤ Process Temp. ° F (° C)	Contacts	Set Points	All except B24, C24, C25-2B10		C25-2B10 only	
				NEMA 4X/7/9 Aluminum Enclosure ⑥			
				Class I, Div. 1, Groups C & D	Class I, Div. 1, Group B	Class I, Div. 1, Groups C & D	Class I, Div. 1, Group B
Series 3 Mercury Switch w/Beaded Leads	750 (399)	SPDT	1	3KA	3KJ	3KB	3KK
			2	3LE	3LG	3LB	3LK
			3	3ME	3MG	3MB	3MK
Series B Snap Switch	250 (121)	SPDT	1	3NA	3NJ	3NB	3NK
			2	3OA	3OJ	3OB	3OK
Series C Snap Switch	450 (232)	SPDT	1	BKA	BKJ	BKB	BKK
			2	BLA	BLJ	BLB	BLK
			3	BMA	BMJ	BMB	BMK
Series 2 Vibration Resistant Mercury Switch w/Beaded Leads	750 (399)	SPDT	1	BNA	BNJ	BNB	BNK
			2	BOA	BOJ	BOB	BOK
Series HS 5 amp Hermetically Sealed Snap Switch w/Wiring Leads	400 (204)	SPDT	1	CKA	CKJ	CKB	CKK
			2	CLA	CLJ	CLB	CLK
			3	CMA	CMJ	CMB	CMK
Series HS 5 amp Hermetically Sealed Snap Switch w/Terminal Block	400 (204)	SPDT	1	CNA	CNJ	CNB	CNK
			2	COA	COJ	COB	COK
Series 2 Vibration Resistant Mercury Switch w/Beaded Leads	750 (399)	SPDT	1	2KA	2KJ	2KB	2KK
			2	2LE	2LG	2LB	2LK
			3	2ME	2MG	2MB	2MK
Series HS 5 amp Hermetically Sealed Snap Switch w/Wiring Leads	400 (204)	SPDT	1	2NA	2NJ	2NB	2NK
			2	2OA	2OJ	2OB	2OK
Series HS 5 amp Hermetically Sealed Snap Switch w/Terminal Block	400 (204)	SPDT	1	—	—	HMJ	HMK
			2	—	—	HMN	HMP
			1	—	—	HMS	HMT
			2	—	—	HMY	HMZ
Series H1 1 amp Hermetically Sealed Snap Switch w/Wiring Leads	750 (399)	SPDT	1	—	—	HM3	HM4
			2	—	—	HM7	HM8
			1	—	—	HKJ	HKK
			2	—	—	HKP	HKK

PNEUMATIC SWITCH MECHANISM AND ENCLOSURE

Switch Description	Maximum Supply Pressure		Maximum Process Temp.		Bleed Orifice Diameter		All except B24, C24	Code B24, C24
	psig	bar	° F	° C	Inches	mm	NEMA 1	
Series J Bleed Type	100	7	400	204	.063	1.6	JDE	—
	60	4	400	204	.094	2.3	JEE	JEG
Series K Non-Bleed Type	100	7	400	204	—	—	KOE	—
	40	3	400	204	—	—	KOG	KOG

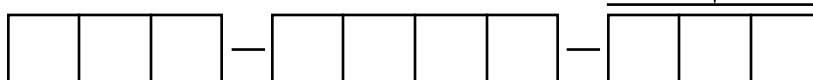

Customer Notes Page

Customer Notes Page

Service Policy

Owners of Magnetrol/STI controls may request the return of a control or any part of a control for complete rebuilding or replacement. They will be rebuilt or replaced promptly. Controls returned under our service policy must be returned by Prepaid transportation. Magnetrol/STI will repair or replace the control at no cost to the purchaser (or owner) other than transportation if:

1. Returned within the warranty period; and
2. The factory inspection finds the cause of the claim to be covered under the warranty.

If the trouble is the result of conditions beyond our control; or, is NOT covered by the warranty, there will be charges for labor and the parts required to rebuild or replace the equipment.

In some cases it may be expedient to ship replacement parts; or, in extreme cases a complete new control, to replace the original equipment before it is returned. If this is desired, notify the factory of both the model and serial numbers of the control to be replaced. In such cases, credit for the materials returned will be determined on the basis of the applicability of our warranty.

No claims for misapplication, labor, direct or consequential damage will be allowed.

Return Material Procedure

So that we may efficiently process any materials that are returned, it is essential that a "Return Material Authorization" (RMA) number be obtained from the factory, prior to the material's return. This is available through Magnetrol's or STI's local representative or by contacting the factory. Please supply the following information:

1. Company Name
2. Description of Material
3. Serial Number
4. Reason for Return
5. Application

Any unit that was used in a process must be properly cleaned in accordance with OSHA standards, before it is returned to the factory.

A Material Safety Data Sheet (MSDS) must accompany material that was used in any media.

All shipments returned to the factory must be by prepaid transportation.

All replacements will be shipped F.O.B. factory.



5300 Belmont Road • Downers Grove, Illinois 60515-4499 • 630-969-4000 • Fax 630-969-9489 • www.magnetrol.com
6291 Dorman Road • Mississauga, Ontario L4V-1H2 • 905-678-2720 • Fax 905-678-7407
Heikensstraat 6 • B 9240 Zele, Belgium • 052 45.11.11 • Fax 052 45.09.93
Regent Business Ctr., Jubilee Rd. • Burgess Hill, Sussex RH15 9TL U.K. • 01444-871313 • Fax 01444-871317



5300 Belmont Road • Downers Grove, Illinois 60515-4499 • 630-969-4028 • Fax 630-969-9489 • www.sticontrols.com

Copyright © 2002 Magnetrol International, Incorporated. All rights reserved. Printed in the USA.
Magnetrol and Magnetrol logotype are registered trademarks of Magnetrol International.
STI and STI logotype are registered trademarks of Magnetrol International.

Performance specifications are effective with date of issue and are subject to change without notice.
The brand and product names contained within this document are trademarks or registered trademarks of their respective holders.

BULLETIN: 46-630.0
EFFECTIVE: August 2002