

# Models F10 and F50

Installation and Operating Manual

*Flow*

*Switches*



Model F10



Model F50

---

## Read this Manual Before Installing

This manual provides information on Model F10 and F50 Flow Switches. It is important that all instructions are read carefully and followed in sequence. Detailed instructions are included in the Installation section of this manual.

## Conventions Used in this Manual

Certain conventions are used in this manual to convey specific types of information. General technical material, support data, and safety information are presented in narrative form. The following styles are used for notes, cautions, and warnings.

### NOTES

Notes contain information that augments or clarifies an operating step. Notes do not normally contain actions. They follow the procedural steps to which they refer.

### Cautions

Cautions alert the technician to special conditions that could injure personnel, damage equipment, or reduce a component's mechanical integrity. Cautions are also used to alert the technician to unsafe practices or the need for special protective equipment or specific materials. In this manual, a caution box indicates a potentially hazardous situation which, if not avoided, may result in minor or moderate injury.

### WARNINGS

Warnings identify potentially dangerous situations or serious hazards. In this manual, a warning indicates an imminently hazardous situation which, if not avoided, could result in serious injury or death.

### Safety Messages

Follow all standard industry procedures for servicing electrical equipment when working with or around high voltage. Always shut off the power supply before touching any components.

**WARNING!** Explosion hazard. Do not connect or disconnect equipment unless power has been switched off or the area is known to be non-hazardous.

## Low Voltage Directive

For use in Installation Category II, Pollution Degree 2. If equipment is used in a manner not specified by the manufacturer, protection provided by the equipment may be impaired.

## Notice of Trademark, Copyright, and Limitations

Magnetrol & Magnetrol logotype are registered trademarks of Magnetrol International.

Copyright © 2010 Magnetrol International, Incorporated. All rights reserved.

Performance specifications are effective with date of issue and are subject to change without notice. Magnetrol reserves the right to make changes to the product described in this manual at any time without notice. Magnetrol makes no warranty with respect to the accuracy of the information in this manual.

## Warranty

All Magnetrol mechanical level and flow controls are warranted free of defects in materials or workmanship for five full years from the date of original factory shipment.

If returned within the warranty period; and, upon factory inspection of the control, the cause of the claim is determined to be covered under the warranty; then, Magnetrol will repair or replace the control at no cost to the purchaser (or owner) other than transportation.

Magnetrol shall not be liable for misapplication, labor claims, direct or consequential damage or expense arising from the installation or use of equipment. There are no other warranties expressed or implied, except special written warranties covering some Magnetrol products.

## Quality Assurance

The quality assurance system in place at Magnetrol guarantees the highest level of quality throughout the company. Magnetrol is committed to providing full customer satisfaction both in quality products and quality service.

Magnetrol's quality assurance system is registered to ISO 9001 affirming its commitment to known international quality standards providing the strongest assurance of product/service quality available.





# F10 and F50 Flow Switches

## Table of Contents

1.0 Introduction		4.0 Reference Information	12
1.0.1 Model F10	4	4.1 Troubleshooting	12
1.0.2 Model F50	4	4.1.1 Check Switch Mechanism	12
1.1 Principle of Operation	4	4.1.2 Test Control's Performance	13
1.1.1 Model F10	4	4.2 Agency Approvals	14
1.1.2 Model F50	4	4.3 Specific Gravity	15
1.2 Operating Cycle	4	4.3.1 Model F10 and F50 Specific Gravity Correction	15
1.2.1 Model F10	4	4.4 Specifications	16
1.2.2 Model F50	5	4.4.1 Model F10 Actuating Flow Rates	16
2.0 Installation	5	4.4.2 Model F50 Actuating Flow Rates	18
2.1 Unpacking	5	4.4.3 Model F10 Dimensional Specifications	19
2.2 Piping	5	4.4.4 Model F50 Dimensional Specifications	20
2.2.1 Model F10	5	4.5 Replacement Parts	21
2.2.2 Model F50	5	4.5.1 Model F10	21
2.3 Mounting	6	4.5.1.1 Model F10 Parts Identification	21
2.3.1 Model F10 Mounting — Threaded Connection	6	4.5.1.2 Model F10 Switch and Housing Reference	21
2.3.1.1 Installation of F10 in Horizontal Line	6	4.5.1.3 Model F10 Threaded Mounting	22
2.3.1.2 Positioning Vane Perpendicular to Flow	6	4.5.1.4 Model F10 Flanged Mounting	22
2.3.1.3 Trimming Vane to fit Horizontal Line Size	7	4.5.2 Model F50	23
2.3.1.4 Final Mounting	7	4.5.2.1 Model F50 Parts Identification	23
2.3.2 Model F10 – Flanged Connection	8	4.5.2.2 Model F50 Switch and Housing Reference	23
2.3.3 Model F50 Mounting	8	4.5.2.3 Model F50 Bronze Body Replacement Parts	24
2.3.3.1 Installation of Model F50	8	4.5.2.4 Model F50 Stainless Steel Replacement Parts	24
2.4 Wiring	8	4.6 Model Numbers	25
2.4.1 Model F10 Switch Actuation Adjustment	9	4.6.1 Model F10	25
3.0 Preventive Maintenance	10	4.6.2 Model F50	26
3.1 What To Do	10		
3.1.1 Keep Control Clean	10		
3.1.2 Inspect Switch Mechanisms, Terminals, and Connections Monthly	10		
3.1.3 Inspect Entire Unit Periodically	11		
3.2 What To Avoid	11		

## 1.0 Introduction

### 1.0.1 Model F10

F10 vane-actuated flow switches provide excellent reliability for a broad spectrum of horizontal pipe flow-sensing applications, including air, oil and petroleum derivatives, corrosive chemicals, and water.

### 1.0.2 Model F50

F50 Flow Switches are utilized, in horizontal lines, to sense the presence or absence of liquid flow in oil, chemical, gas, and water lines.

## 1.1 Principle of Operation

### 1.1.1 Model F10

The flow of liquid or gas through a pipeline applies a force to a flow vane inserted into the pipeline. When flow is sufficient such that the force on the vane moves the vane, it is pivoted up, parallel to the flow. This movement causes an attraction sleeve to move into the field of a magnet. The magnet moves toward the sleeve causing actuation of the switch.

### 1.1.2 Model F50

The flow of liquid through the valve body applies a force to a flow disc. This in turn raises the magnetic sleeve, within its sealed non-magnetic enclosing tube into the field of the switch magnet, located outside the enclosing tube, actuating the attached switch mechanism.

## 1.2 Operating Cycle

### 1.2.1 Model F10

Sufficient flow through a pipeline causes the pivoted vane assembly to swing in the direction of the flow. The vane assembly rotates a cam which lifts an attraction sleeve, which in turn causes the magnet to pull in and actuate the switch.

The O-ring sealed adjusting screw, in the top of the enclosing tube, compresses the range spring located above the attraction sleeve. Turning the adjusting screw clockwise, increases the flow rate at which the switch actuates. Adjustments can be made while the flow switch is in service.

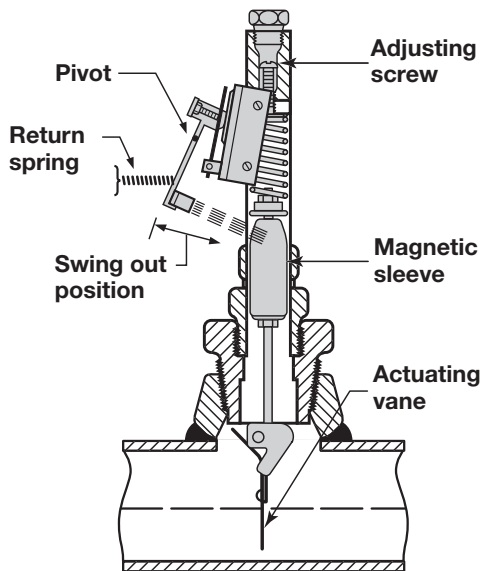

Figure 1—No Flow Position

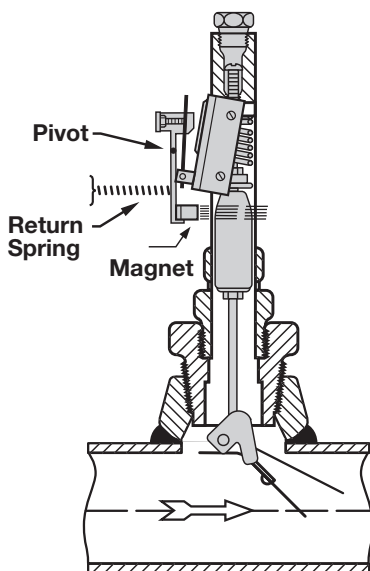

Figure 2—Position w/Actuating Flow Present

## 1.2.2 Model F50

On an increasing flow rate, the flow disc moves the attraction sleeve up within the field of a switch magnet, drawing it in tightly to the enclosing tube. This causes the switch to make or break an electrical circuit. When the flow rate drops, below the rate for which the flow disc is calibrated, the attraction sleeve is pulled downward until, at a predetermined low flow rate, the switch magnet releases and swings outward, away from the enclosing tube, causing a reversal of the switching action.

## 2.0 Installation

This section provides detailed procedures for properly installing Model F10 and F50 Flow Switches.

### 2.1 Unpacking

**Caution:** If equipment is used in a manner not specified by the manufacturer, protection provided by the equipment may be impaired.

Unpack the instrument carefully, inspecting all components for damage. Report any concealed damage to the carrier within 24 hours. Check the contents of the carton/crate against those listed on the packing slip, and report any discrepancy to the factory. Check the part number on the nameplate to be certain it agrees with the part number shown on the packing slip and purchase order. Record the serial number for future reference when ordering parts.

### 2.2 Piping

**NOTE:** For proper performance, a straight pipe run of 12 pipe diameters up stream and 3 pipe diameters downstream of the switch is recommended.

#### 2.2.1 Model F10

The F10 flow switch should be located in a horizontally run pipe with the arrow on the body bushing or mounting flange pointing in the direction of flow.

#### 2.2.2 Model F50

The Model F50 flow switch should be located in a horizontal pipe run, with the arrow on the valve body pointing in the direction of flow. The switch housing must always be above the valve body.

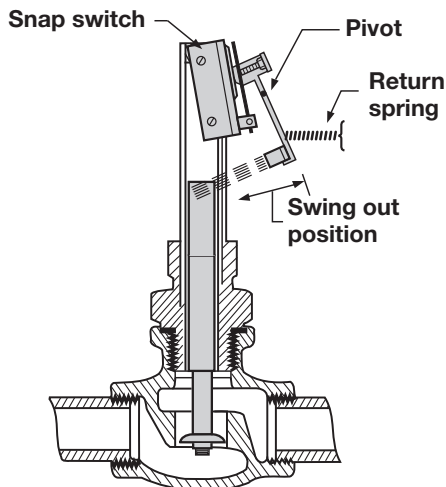

Figure 3—No Flow Position

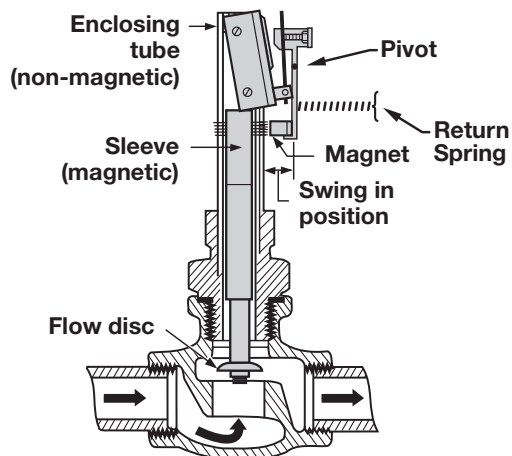

Figure 4—Position w/Actuating Flow Present

## 2.3 Mounting

**Caution:** This instrument is intended for use in Installation Category II, Pollution Degree 2.

### 2.3.1 Model F10 Mounting – Threaded Connection

#### 2.3.1.1 Installation of F10 in Horizontal Line

1. Insert a length of pipe in two inch, 3,000 lb. threadolet fitting.
2. Plumb the vertical center line of the fitting and trace around the fitting to locate center line of required 2.62 inch (67 mm) diameter hole. Refer to Figure 5.
3. Clean up inside edges of hole, and remove any slag on the bottom of line that could interfere with vane.
4. With fitting concentrically positioned over the 2.62 inch (67 mm) diameter hole, and the vertical center line held plumb (refer to Figure 6), tack weld the fitting at four equally spaced points. After tacking, remove .06 inch (2 mm) diameter spacer wire. Refer to Figure 5.

**NOTE:** A hole in the pipeline less than 2.62 inches (67 mm) in diameter will limit travel of the pivoted vane. If this condition cannot be avoided, the width of the vane should be reduced to 1.50 inches (38 mm) maximum.

**IMPORTANT:** For installation in 2.00 inch pipe lines, disregard 2.62 inch (67 mm) dimension and use inside of threadolet as template.

5. Proper operation of the F10 depends upon the vertical center line of the 2" NPT coupling being plumb within 3°. Keep fitting plumb while welding the continuous passes, according to threadolet manufacturers installation procedure.

#### 2.3.1.2 Positioning Vane Perpendicular to Flow

1. With large and small vanes unassembled, tighten the F10 body bushing into the coupling on the pipeline, until one of the three decal flow arrows is pointing parallel with flow.
2. Mark the bushing thread, even with the top of the threadolet, as a reference point for trimming vane to correct length. Remove two arrows not parallel with the pipe.
3. Remove the F10 from pipeline.

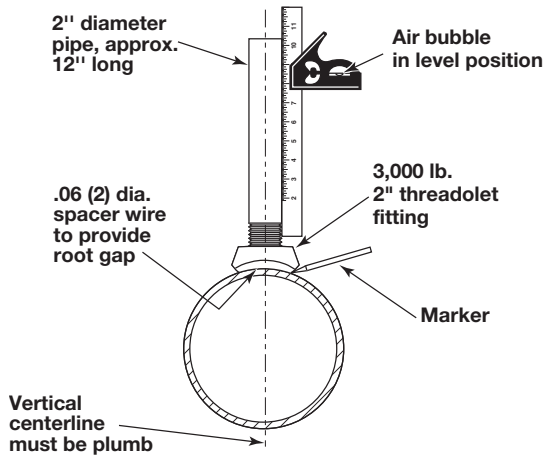

Figure 5

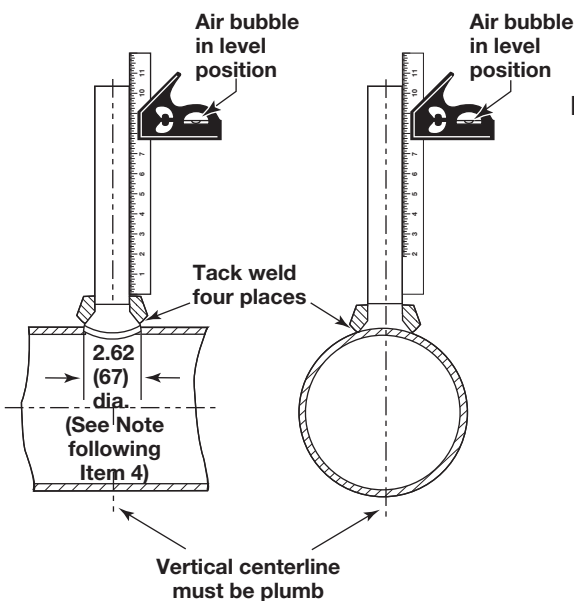

Figure 6

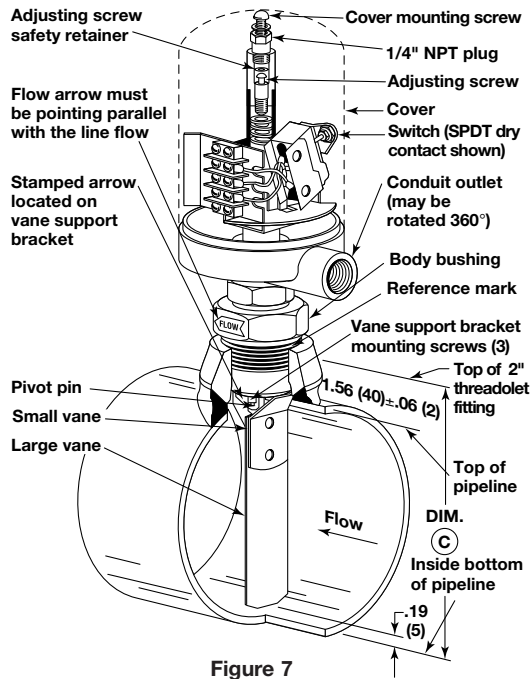

Figure 7

4. Check position of the arrow stamped on vane support bracket. This arrow should be pointing parallel with the flow arrow on the body bushing. Refer to Figure 7. If arrows are not parallel, remove the three vane support bracket mounting screws and rotate bracket until the stamped arrow is pointing parallel with the flow arrow; replace mounting screws.

### 2.3.1.3 Trimming Vane to Fit Horizontal Line Size

The F10 is furnished as standard with vanes suitable for use on 2.00 inch through 30.00 inch pipelines. Assemble vane (or vanes) to F10 and trim according to applicable line size as follows:

2.00 inch line (Sch 40):

Use small vane only. No cutting should be necessary.

2.50 inch line:

Use small vane, with large vane trimmed to 1.50 inches wide (same as small vane) and length trimmed to dimension "C" less .19 inch (5 mm). Refer to Figure 8.

3.00 inch line and up:

Use small vane, with large vane trimmed to dimension "C" less .19 inch (5 mm). Refer to Figure 8. Upon final assembly of trimmed vanes, firmly tighten two screws.

It is recommended that the lower retaining screw be peened over on the threaded end.

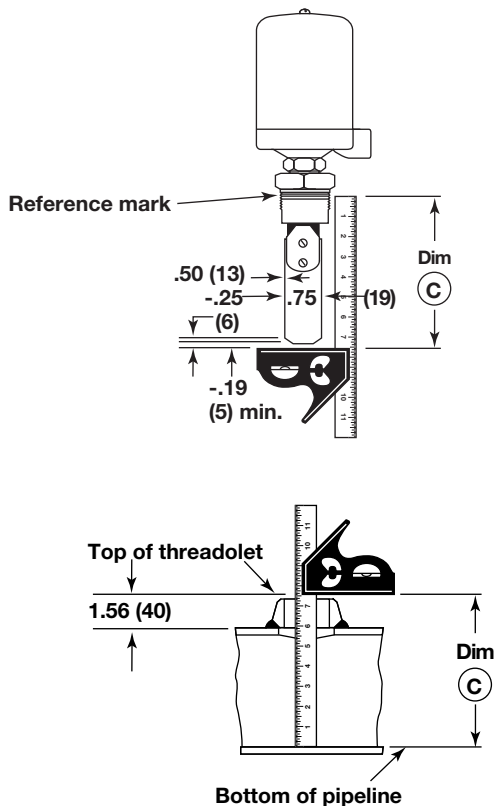

Figure 8

### 2.3.1.4 Final Mounting

1. Apply sealing compound to body bushing threads.
2. Thread F10 into threadolet fitting and tighten body bushing to the same seal tight position so that the flow arrow is pointing parallel with the line flow. Refer to item #1, *Section 2.3.1.2, Positioning Vane Perpendicular to Flow.*
3. Connect conduit and power lines.

## 2.3.2 Model F10 — Flanged Connection

NOTE: For proper performance, a straight pipe run of 12 pipe diameters up stream and 3 pipe diameters downstream of the switch is recommended.

Figure 9 shows one method which may be used to mount the F10 flow switch to 2.50 to 30.00 inch run pipes. Before final welding, alignment of mounting flange should be checked to be certain it is plumb. Finished mounting must allow control switch housing to be within three degrees of vertical for proper operation. A three-degree slant is noticeable by eye, but installation should be checked with a spirit level.

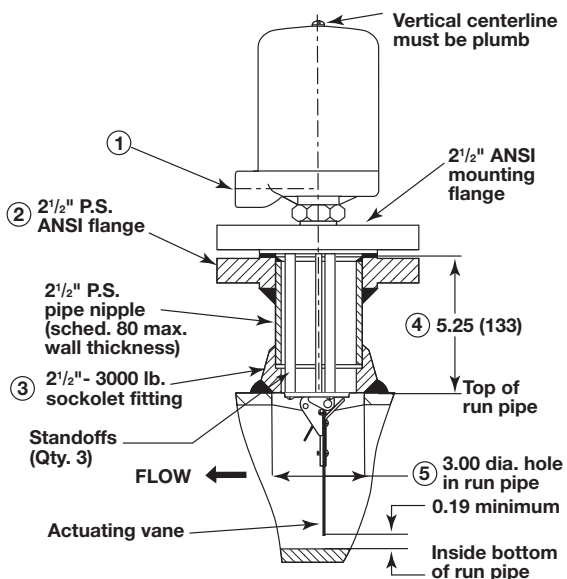

Figure 9

### NOTES:

- ① Conduit outlet may be rotated 360° for wiring convenience.
- ② Flange to match flange of F10 flow switch and positioned with bolt holes straddling center lines.
- ③ For proper attachment procedure, refer to fitting manufacturer's recommendation.
- ④ Dimension shown is for use with 0.06 inch (2 mm) thick flange gasket. If thicker gasket is used, reduce dimension amount equal to additional thickness.
- ⑤ For run pipe sizes over 2.50 inch P.S. only. For installation on 2.50 inch run pipes, disregard 3.00 inch dimension and use inside of adaptor fitting as template.
- ⑥ Follow appropriate sections under threaded connection mounting to position the vane perpendicular to the flow and trim vane to size.

## 2.3.3 Model F50 Mounting

### 2.3.3.1 Installation of Model F50

1. When installing, use wrenches on valve body only. Do not attempt to tighten or draw-up valve body on the pipe by pulling or pushing on switch housing cover.
2. Adjust pipe alignment, as required, to bring switch housing to a vertical position above pipeline. F50 flow switches must be mounted within three degrees of vertical. Three degree slant is noticeable to the eye, but installation should be check with a spirit level on the side of the enclosing tube at two places, 90 degrees apart.

NOTE: On flow switches using pneumatic switch assemblies, consult bulletin on mechanism furnished for air (or gas) piping instructions.

NOTE: For proper performance, a straight pipe run (12 pipe diameters upstream, and three pipe diameters downstream of the switch), is recommended.

## 2.4 Wiring

**Caution:** Level controls are shipped from the factory with the enclosing tube tightened and the middle set screw, on the housing base, locked to the enclosing tube. Failure to loosen the set screw prior to repositioning the conduit connection may cause the enclosing tube to loosen, resulting in the possible leakage of the process liquid or vapor.

NOTE: A switch or circuit breaker shall be installed in close proximity to equipment and within easy reach of operator. It shall be marked as the disconnecting device for the equipment.

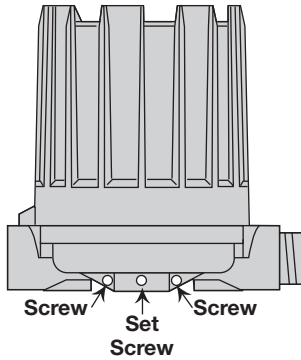

Figure 10

1. On high temperature applications, above +250° F (+121° C), high temperature wire should be used between the control and first junction box located in a cooler area.
2. Remove switch housing to gain access to switch mechanism.

NOTE: For supply connections in installations with ambient temperature up to +70° C, use wire with a minimum rating of +75° C as required by the process conditions,. Installations with ambient temperatures up to +80° C require wire with a minimum rating of +85° C as required by the process conditions. Use a minimum of 14 AWG wire for power and ground field wires.

3. Pull in supply wires (conductors), wrap them around enclosing tube beneath the baffle plate, and connect to proper terminals. Ensure excess wire does not interfere with actuation of the switch, and that adequate clearance exists for replacement of switch housing cover.
4. Connect power supply to control and test switch actuation by varying flow rate within pipeline.

NOTE: If switch mechanism fails to function properly, check vertical alignment of control housing. Refer to installation bulletin of mechanism furnished, as listed in the switch mechanism chart on page 21.

5. Replace switch housing cover.

NOTE: NEMA 4X/7/9 housings must be sealed at the conduit outlet with suitable compound to prevent entrance of air. Check cover to base fit to be certain gasketed joint is tight. A positive seal is necessary to prevent infiltration of moisture laden air or corrosive gases into switch housing.

6. Place flow switch into service.

#### 2.4.1 Model F10 Switch Actuation Adjustment

The F10 flow switch is factory set to actuate at the minimum flow rate. Actuation flow rate can be increased while the unit is in service, under pressure, by removing the ¼" NPT plug to gain access to the O-ring sealed adjusting screw. Each clockwise turn of the adjusting screw increases the actuating flow rate approximately 10% of the range of the specific flow vane being used. *See pages 16–18 for flow rate adjustability.*

**Caution:** The safety retainer above the adjusting screw is placed there to help prevent the accidental removal of the adjusting screw. Do not defeat its purpose by forcefully backing out the adjustment screw. Be sure to replace the ¼" NPT plug and tighten it firmly.

---

## 3.0 Preventive Maintenance

Periodic inspections are a necessary means to keep your flow switch in good working order. This control is a safety device to protect the valuable equipment it serves. A systematic program of preventive maintenance must be implemented when the control is placed into service. If the following is observed, your control will provide reliable protection of your capital equipment for many years.

### 3.1 What To Do

#### 3.1.1 Keep Control Clean

Be sure the switch housing cover is always in place on the control. This cover is designed to keep dust and dirt from interfering with the switch mechanism operation. In addition, it protects against damaging moisture and acts as a safety feature by keeping bare wires and terminals from being exposed. Should the housing cover, or any seals become damaged or misplaced, obtain a replacement immediately.

#### 3.1.2 Inspect Switch Mechanisms, Terminals, and Connections Monthly

- a. Dry contact switches should be inspected for excessive wear on actuating lever or misalignment of adjustment screw at point of contact between screw and lever. Such wear can cause false switch actuating levels. Adjust switch mechanism to compensate (if possible) or replace switch.
- b. DO NOT operate your control with defective or maladjusted switch mechanism (refer to bulletin on switch mechanisms furnished for service instructions).
- c. Controls may sometimes be exposed to excessive heat or moisture. Under such conditions, insulation on electrical wiring may become brittle, eventually breaking or peeling away. The resulting bare wires can cause short circuits.  
Check wiring carefully, and replace it at the first sign of brittle insulation.
- d. Vibration may sometimes cause terminal screws to work loose. Check all terminal connections to be certain that screws are tight.
- e. On units with pneumatic switches, air (or gas) operating medium lines, subjected to vibration, may eventually crack or become loose at connections causing leakage. Check lines and connections carefully and repair or replace, if necessary.

---

NOTE: As a matter of good practice, spare switches should be kept on hand at all times.

### **3.1.3 Inspect Entire Unit Periodically**

Increase and decrease liquid flow through the pipeline to check for switch contact and reset.

## **3.2 What To Avoid**

1. NEVER leave switch housing cover off the control longer than necessary to make routine inspection.
2. NEVER place a jumper wire across terminals to cut-out the control. If a jumper is necessary for test purposes, be certain it is removed before placing control into service.
3. NEVER attempt to make adjustments or replace switches without reading instructions carefully. Certain adjustments provided for in flow switches should not be attempted in the field. When in doubt, consult the factory or your local representative.
4. NEVER use lubricants on pivots of switch mechanisms. A sufficient amount of lubricant has been applied at the factory to ensure a lifetime of service. Further lubrication is unnecessary, and will only tend to attract dust and dirt which can interfere with mechanism operation.

---

## 4.0 Reference Information

### 4.1 Troubleshooting

Usually the first indication of improper operation is failure of the controlled equipment to function, i.e., pump will not start (or stop), signal lights fail to light, etc. When these symptoms occur, whether at time of installation or during routine service thereafter, check the following potential external causes first.

- a. Fuses may be blown.
- b. Reset button(s) may need resetting.
- c. Power switch may be open.
- d. Controlled equipment may be faulty.

If a thorough inspection of these possible conditions fails to locate the trouble, proceed to a check of the control's switch mechanism.

#### 4.1.1 Check Switch Mechanism

1. Pull disconnect switch, or otherwise assure that electrical circuit(s) of control are deactivated.
2. Remove switch housing cover.
3. Swing magnet assembly in and out by hand, checking carefully for any sign of binding. Assembly should require minimal force to move it through its full swing.
4. If binding exists, magnet may be rubbing enclosing tube. If magnet is rubbing, loosen magnet clamp screw, and shift magnet position.
5. If switch magnet assembly swings freely, and mechanism still fails to actuate, check installation of control to be certain it is within the specified three degrees of vertical. Use a spirit level on side of enclosing tube in two places, 90 degrees apart.

NOTE: As a matter of good practice, spare switches should be kept on hand at all times.

If switch mechanism is operating satisfactorily, a test of the complete control's performance is the next likely step.

---

#### 4.1.2 Test Control's Performance

If switch mechanism is operating satisfactorily, a test of the complete control's performance is the next likely step.

1. Reconnect power supply, and carefully actuate switch mechanism manually, using a non-conductive tool, to determine whether controlled equipment will operate.

**Caution:** With electrical power on, care should be taken to avoid contact with switch leads and connections at terminal block.





2. If controlled equipment responds to manual actuation test, trouble may be located in the flow sensing portion of the control.

NOTE: Check first to be certain liquid is flowing through pipeline. A valve may be closed, or pipeline may be plugged.

3. If magnet fails to pull in on increasing flow:
  - a. Disk or vane may not be sized properly for required actuation flow rate.
  - b. Check for hang-up or deposits in disk seat or at vane pivot.
  - c. Check for malfunctioning by manually moving magnet carriage.
4. If magnet fails to pull out on decreasing flow:
  - a. Disk or vane may not be sized properly for required actuation flow rate.
  - b. Check for hang-up or deposits in disk seat or at vane pivot.
  - c. Check for malfunctioning by manually moving magnet carriage.

If all components in the unit are in operating condition, the trouble must be located external to the unit. Repeat inspection of external conditions previously described.

## 4.2 Agency Approvals

AGENCY	MODEL	APPROVAL	CATEGORIES
<b>FM</b>  APPROVED	F10-XXXX-XXX	with an electric switch mechanism and a housing listed as Type 4X/7/9	Class I, Div 1, Groups C & D Class II, Div 1, Groups E, F & G
	F50-XXXX-XXX	with an electric switch mechanism and a housing listed as Type 4X/7/9	Class I, Div 1, Groups C & D Class II, Div 1, Groups E, F & G
<b>CSA</b> 	F10-XXXX-XXX	with a Series F or HS electric switch mechanism and a housing listed as CSA Type 4X	Class I, Div 2, Group B
	F50-XXXX-XXX	with an electric switch mechanism and a housing listed as Type 4X/7/9	Class I, Div 1, Groups C & D Class II, Div 1, Groups E, F & G
	F10-XXXX-XXX	with an electric switch mechanism and a housing listed as Type 4X/7/9	Class I, Div 1, Groups B, C & D Class II, Div 1, Groups E, F & G
<b>ATEX/IEC Ex</b> ① 	F10-XXXX-XXX	with an electric switch mechanism and an ATEX housing	ATEX II 2 G EEx d IIC T6 94/9/EC IEC Ex Ex d IIC T6 IP66
	F50-XXXX-XXX		
<b>CE</b> 	F10-XXXX-XXX	Low Voltage Directives 2006/95/EC	Installation Category II
	F50-XXXX-XXX	Per Harmonized Standard: EN 61010-1/1993 & Amendment No. 1	Pollution Degree 2

① IEC Installation Instructions:

The cable entry and closing devices shall be Ex d certified suitable for the conditions of use and correctly installed.

For ambient temperatures above +55° C or for process temperatures above +150° C, suitable heat resistant cables shall be used.

Heat extensions (between process connection and housing) shall never be insulated.

### Special conditions for safe use:

When the equipment is installed in process temperatures higher than +85° C the temperature classification must be reduced according to the following table as per IEC60079-0.

Maximum Process Temperature	Temperature Classification
< 85° C	T6
< 100° C	T5
< 135° C	T4
< 200° C	T3
< 300° C	T2
< 450° C	T1

These units are in conformity with IECEx KEM 05.0020X

Classification Ex d IIC T6

T<sub>ambient</sub> -40° C to +70° C

---

## 4.3 Specific Gravity

### 4.3.1 Model F10 and F50 Specific Gravity Correction

---

To determine the actuating flow rates for liquids other than water (approximate viscosity of 20 centistokes or less), a specific gravity correction factor must be applied to the water flow rates given in the table.

Example: The maximum adjustment for an increasing flow rate with a liquid specific gravity of .70 in an 8" line is: 230 GPM x 1.20 = 276 GPM.

Specific Gravity	Multiplication Factor	Specific Gravity	Multiplication Factor
.40	1.58	.95	1.03
.45	1.49	1.00	1.00
.50	1.41	1.05	.98
.55	1.35	1.10	.95
.60	1.29	1.15	.93
.65	1.24	1.20	.91
.70	1.20	1.25	.89
.75	1.15	1.30	.88
.80	1.12	1.35	.86
.85	1.08	1.40	.85
.90	1.05	1.45	.83

## 4.4 Specifications

### 4.4.1 Model F10 Actuating Flow Rates

#### Water Service GPM

Model F10 units may be adjusted in service to actuate within the minimum and maximum flow rates given below. A specific gravity correction factor is applied for liquids other than water (1.00 specific gravity). A vane length equal to the line size of the horizontal pipe is required.

Pipe Line Size ① Inches	Flow Increase (GPM)		Flow Decrease (GPM)	
	Minimum	Maximum ②	Minimum	Maximum
2	21	63	16	48
2½	26	74	20	56
3	32	88	24	65
3½	38	100	28	75
4	45	120	33	85
5	61	150	43	110
6	79	180	55	130
8	120	230	82	160
10	170	310	110	210
12	230	380	150	250
14	270	430	170	280
16	340	510	220	320
18	430	590	270	370
20	520	690	320	430
22	620	780	380	480
24	730	900	450	550
26	850	1030	520	620
28	980	1160	590	700
30	1110	1290	670	780

① Based upon Sch 40 pipe.

② For higher flow rates consult factory.

## 4.4 Specifications

### 4.4.1 Model F10 Actuating Flow Rates (cont.)

#### Water Service m<sup>3</sup>/h

Model F10 units may be adjusted in service to actuate within the minimum and maximum flow rates given below. A specific gravity correction factor is applied for liquids other than water (1.00 specific gravity).

Pipe Line Size ① Inches	Flow Increase (m <sup>3</sup> /h)		Flow Decrease (m <sup>3</sup> /h)	
	Minimum	Maximum ②	Minimum	Maximum
2	4.8	14.3	3.6	10.9
2½	5.2	16.8	4.5	12.7
3	7.3	20.0	5.4	14.8
3½	8.6	22.7	6.4	17.0
4	10.2	27.2	7.5	19.3
5	13.8	34.1	9.8	25.0
6	17.9	40.9	12.5	29.5
8	27.2	52.2	18.6	36.3
10	38.6	70.4	25.0	47.7
12	52.2	86.3	34.1	56.8
14	61.3	97.6	38.6	63.6
16	77.2	115.8	49.9	72.6
18	97.6	133.8	61.3	84.0
20	118.0	156.6	72.6	97.6
22	140.7	177.1	86.3	109.0
24	165.7	204.3	102.2	124.9
26	193.0	233.8	118.0	140.7
28	222.5	263.3	133.9	158.9
30	252.0	292.8	152.1	177.1

① Based upon Sch 40 pipe.

② For higher flow rates consult factory.

#### 4.4.2 Model F50 Actuating Flow Rates

Pipe Size (NPT)	Actuating Flow Rate, GPM Water Flow Increasing and Decreasing Rate					
	A	B	C	D	E	F
3/4"	Not Available	1.1 inc.	1.6 inc.	2.3 inc.	3.4 inc.	4.9 inc.
		0.8 dec.	1.2 dec.	1.8 dec.	2.6 dec.	3.7 dec.
1"	1.0 inc.	1.7 inc.	2.5 inc.	3.7 inc.	5.5 inc.	7.1 inc.
	0.8 dec.	1.4 dec.	2.1 dec.	3.0 dec.	4.5 dec.	5.8 dec.
1 1/2"	1.3 inc.	2.7 inc.	4.7 inc.	7.6 inc.	12.3 inc.	21.1 inc.
	1.1 dec.	2.3 dec.	4.0 dec.	6.5 dec.	10.5 dec.	17.9 dec.
2"	1.9 inc.	3.1 inc.	5.1 inc.	8.4 inc.	14.3 inc.	24.8 inc.
	1.6 dec.	2.7 dec.	4.3 dec.	7.1 dec.	12.1 dec.	21.0 dec.

### 4.4.3 Model F10 Dimensional Specifications

Inches (mm)

**NOTE:** For proper performance, a straight pipe run of 12 pipe diameters upstream and 3 pipe diameters downstream of the switch is recommended.

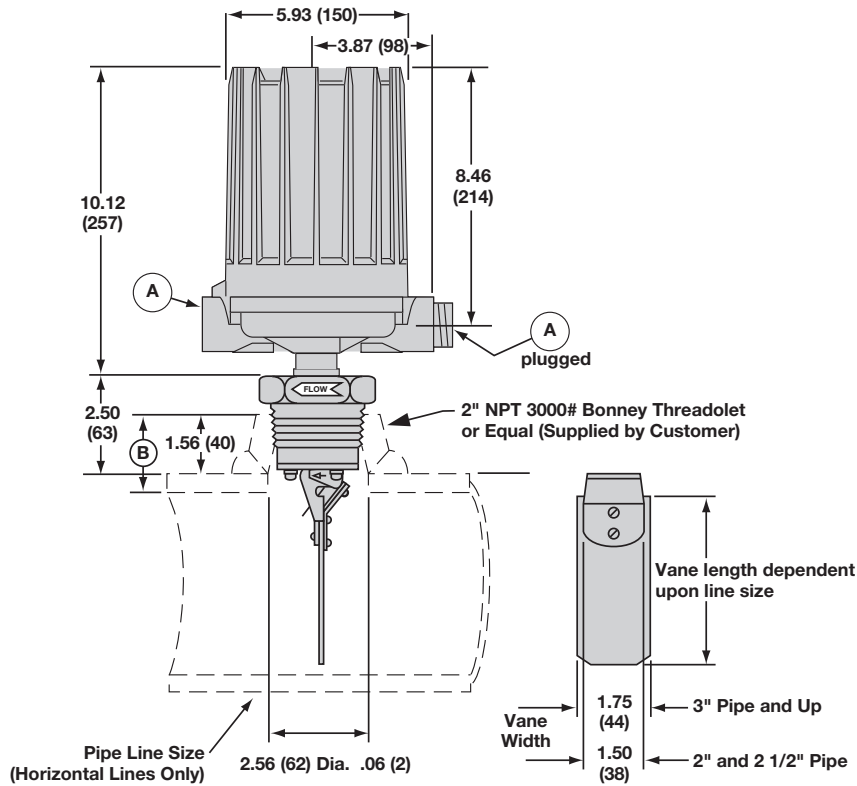

Line Size	Dim. B Max.	Equivalent Max. Wall Schedule
2"	1.81 (46)	80
2½"	1.94 (49)	160
3"	1.88 (48)	80
3½"	1.88 (48)	80
4"	2.00 (51)	120
5"	2.06 (52)	120
6"	2.12 (54)	120
8"	2.19 (56)	100
Over 8"	2.31 (59)	—

**F10 with 2" NPT Connection**

CONDUIT CONNECTIONS A	
Electrical Switches:	
NEMA 4X/7/9:	1" NPT
Group B:	1" NPT
Pneumatic Switches:	
NEMA 1:	¼" NPT

All housings rotatable 360°

**Notes:**

- Allow the following for overhead clearance for cover removal:
  - NEMA 1 — 8.00 (203)
  - NEMA 4X/7/9 — 10.00 (254)
  - Group B — 10.00 (254)

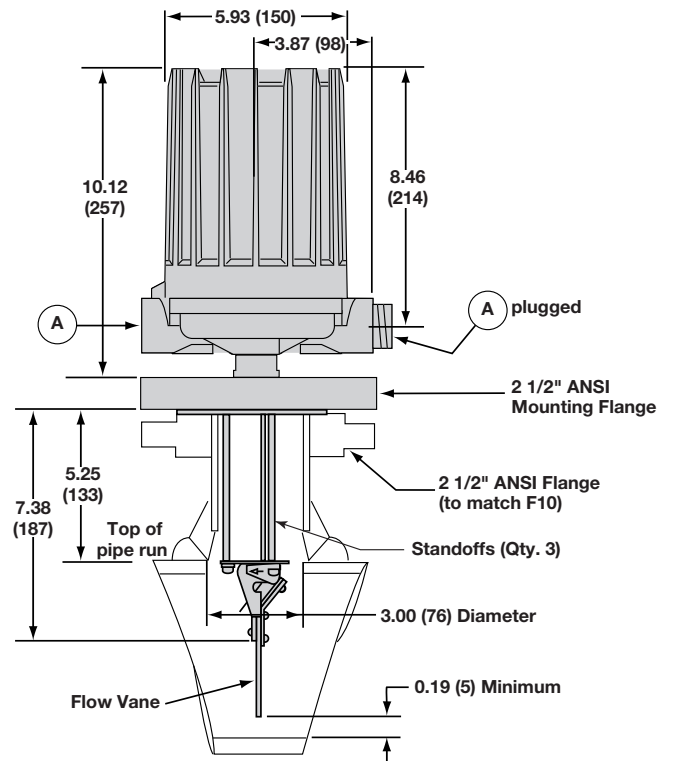

**F10 with Flanged Connection**

## 4.4.4 Model F50 Dimensional Specifications

Inches (mm)

### NOTE:

1. For proper performance, a straight pipe run of 12 pipe diameters upstream and 3 pipe diameters downstream of the switch is recommended.
2. For NEMA 4X/7/9 allow 8.00 (203) overhead clearance for cover removal.

Conduit Connections E	
Electrical Switches	
NEMA 4X/7/9:	1" NPT
Group B:	1" NPT
Pneumatic Switches	
NEMA 1:	1/4" NPT

Outline Dimensions				
Housing	A	B	C*	D
NEMA 4X/7/9	5.93 (151)	4.29 (108)	9.75 (247)	3.60 (91)
NEMA 4X/7/9 Group B	5.93 (151)	4.29 (108)		
NEMA 1 Pneumatic	4.70 (119)	5.00 (127)	8.44 (214)	3.44 (87)

\* This dimension increases by 2.19" (55) when the unit is supplied with an HS hermetically sealed switch with terminal block

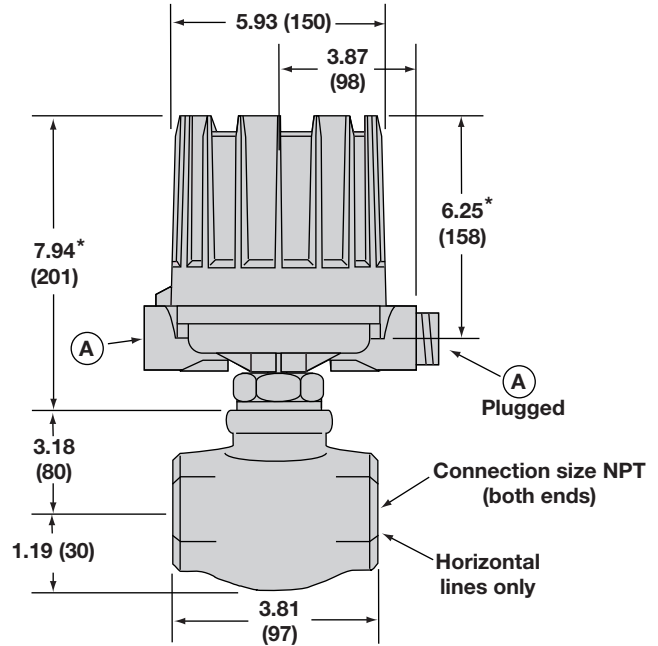

F50 Flow Switch with 3/4" or 1" NPT Internal Pipe, Bronze or Stainless Steel Body

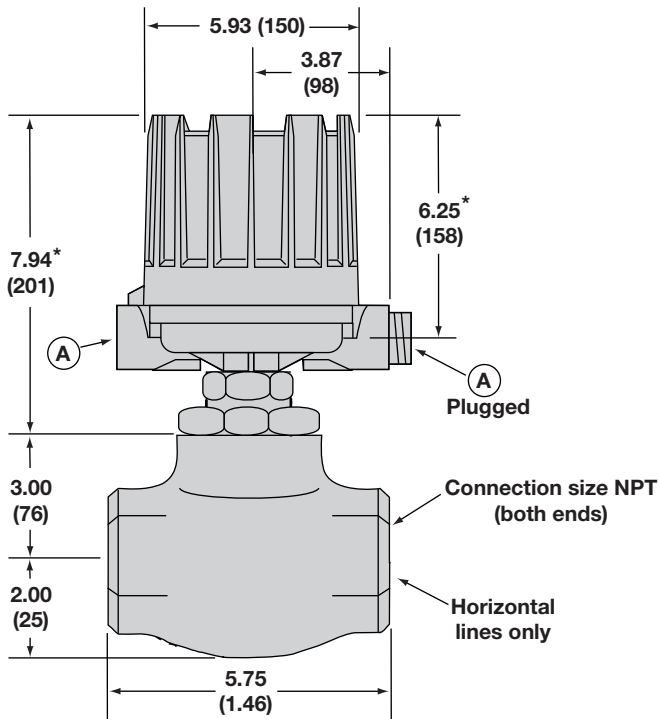

F50 Flow Switch with 1 1/2" or 2" NPT Internal Pipe, Bronze or Stainless Steel Body

Outline Dimensions				
Housing	A	B	C*	D
NEMA 4X/7/9	5.93 (151)	4.29 (108)	10.75 (273)	4.60 (116)
NEMA 4X/7/9 Group B	5.93 (151)	4.29 (108)		
NEMA 1 Pneumatic	4.70 (119)	5.00 (127)	9.44 (240)	4.44 (113)

\* This dimension increases by 2.19" (55) when the unit is supplied with an HS hermetically sealed switch with terminal block

## 4.5 Replacement Parts

### 4.5.1 Model F10

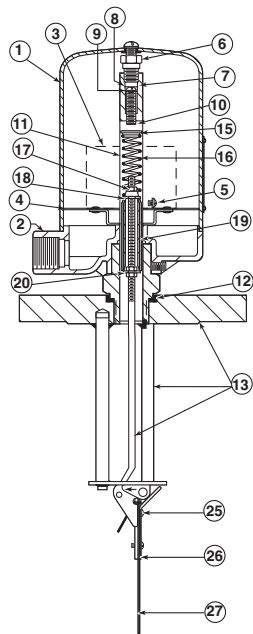

Figure 11 — F10 with Flange Connection

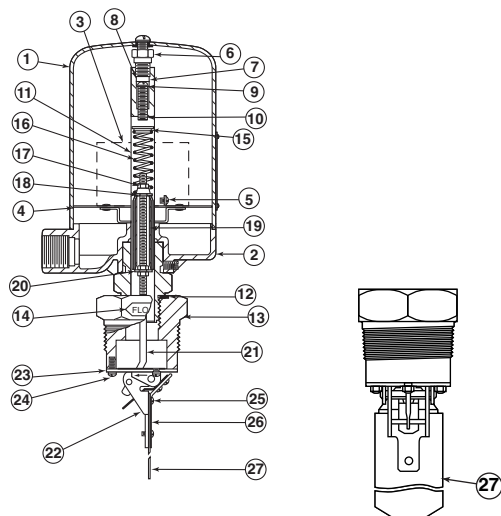

Figure 12 — F10 with Threaded Connection

#### 4.5.1.1 Model F10 Parts Identification

1	Housing cover
2	Housing base
3	Switch mechanisms
4	Baffle plate
5	6-32 round head screw
6	1/4-20 NPT plug
7	Safety retainer
8	Washer
9	O-ring
10	Adjustment screw
11	Enclosing tube
12	Enclosing tube gasket
13	Body bushing or stem, cam follower & flange assy.
14	Flow arrow
15	Upper spring guide
16	Range spring
17	10-32 hex nut
18	Lower spring guide
19	Attraction sleeve
20	Washer
21	Stem assembly
22	Cam assembly
23	No. 8 lock washer
24	8-32 fillister head screw
25	8-32 round head screw
26	Small vane
27	Large vane

#### 4.5.1.2 Model F10 Switch and Housing Reference

	Series Type	Bulletin #
Dry contact	B, C, D	42-683
Hermetically sealed	HS	42-694
Bleed type pneumatic	J	42-685
Non-bleed type pneumatic	K	42-686

#### IMPORTANT:

When ordering replacement parts, please specify:

- A. Model and serial number of control.
- B. Name and number of replacement part.

## 4.5.1 Model F10 (continued)

### 4.5.1.3 Model F10 Threaded Mounting

	Carbon Steel	304 SS	316 SS
Housing cover	See Switch and housing reference on previous page		
Housing base	See Switch and housing reference on previous page		
Switch mechanism	See Switch and housing reference on previous page		
Baffle plate	036-5303-001		
6-32 round head screw	010-1409-005		
Enclosing tube kit: includes items 6 through 11	089-5912-001	089-5913-001	089-5914-001
Enclosing tube gasket	012-1204-001		
Body bushing	089-5704-001	089-5705-001	089-5706-001
Flow arrow	005-9822-001		
Stem assembly kit: includes items 14 through 24	089-5541-001		089-5542-001
Vane kit: includes items 25 through 27	089-6703-001 — Consult factory for pipe runs over 8"		

### 4.5.1.4 Model F10 Flanged Mounting

	Forged Steel	304 SS	316 SS	
Housing cover	See Switch and housing reference on previous page			
Housing base	See Switch and housing reference on previous page			
Switch mechanism	See Switch and housing reference on previous page			
Baffle plate	036-5303-001			
6-32 round head screw	010-1409-005			
Enclosing tube kit: includes items 6 through 11	089-5928-001	089-5929-001	089-5930-001	
Enclosing tube gasket	012-1204-001			
Stem, cam follower, and flange assy.	150 lb.	032-7203-001	032-7204-001	032-7205-001
	300 lb.	032-7203-002	032-7204-002	032-7205-002
	600 lb.	032-7203-003	032-7204-003	032-7205-003
Attraction sleeve and spring kit:				
includes items 14 through 20	089-5544-001		089-5545-001	
Vane kit: includes items 25 through 27	089-6703-001 — Consult factory for pipe sizes over 8"			

## 4.5.2 Model F50

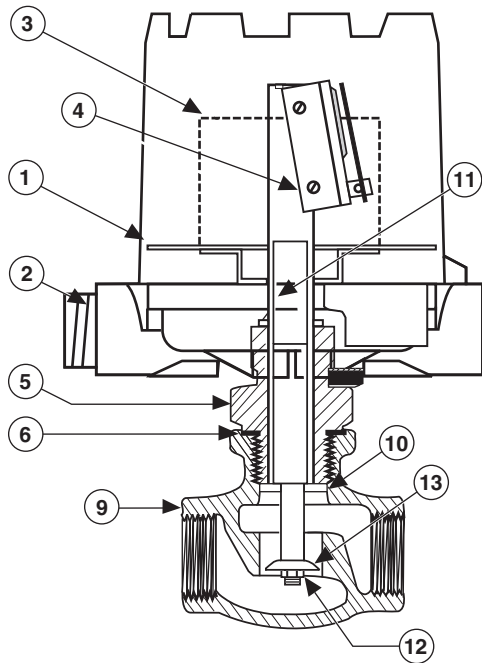

### 4.5.2.1 Model F50 Parts Identification

1	Housing cover
2	Housing base
3	Switch mechanism
4	Switch
5	Enclosing tube
6	E-tube gasket
7	O-ring (not shown)
8	Body adaptor (not shown)
9	Threaded body
10	Flow piston stop
11	Flow piston assy <sup>①</sup>
12	Lock nut <sup>②</sup>
13	Flow disc <sup>③</sup>

<sup>①</sup> Highly corrosive applications use piston assembly with sheathed attraction sleeve. Consult local representative for ordering assistance.

<sup>②</sup> Use insoluble adhesive on nut when attaching new flow disc.

<sup>③</sup> When actuated flow rate is critical, the entire control **must** be returned to the factory for replacement and recalibration of flow disc.

### 4.5.2.2 Model F50 Switch and Housing Reference

	Series Type	Bulletin #
Dry contact	B, C, D	42-683
Hermetically sealed	F	42-683
Hermetically sealed	HS	42-694
Bleed type pneumatic	J	42-685
Non-bleed type pneumatic	K	42-686

#### IMPORTANT:

When ordering replacement parts, please specify:

- A. Model and serial number of control.
- B. Name and number of replacement part.

## 4.5.2 Model F50 (continued)

### 4.5.2.3 Model F50 Bronze Body Replacement Parts

	¾"	1"	1½"	2"
Housing cover	See Switch and housing reference on previous page			
Housing base	See Switch and housing reference on previous page			
Switch mechanism	See Switch and housing reference on previous page			
Switch	See Switch and housing reference on previous page			
Enclosing tube	Z32-6325-002			
Enclosing tube gasket	012-1204-001			
O-ring	Not required		012-1204-036	
Body adaptor	Not required		004-0481-001	
Threaded body	002-5703-003	002-5703-004	002-5705-003	002-5705-004
Flow piston stop	005-5420-121		Not required	
Flow piston assembly	032-7127-001	032-7127-003	032-7127-002	
Lock nut <sup>①</sup>	010-2107-002	010-2107-003		
Flow disc <sup>②</sup>	Specify model number and serial number			

### 4.5.2.4 Model F50 Stainless Steel Body Replacement Parts

	¾"	1"	1½"	2"
Housing cover	See Switch and housing reference on previous page			
Housing base	See Switch and housing reference on previous page			
Switch mechanism	See Switch and housing reference on previous page			
Switch	See Switch and housing reference on previous page			
Enclosing tube	Z32-6325-002			
Enclosing tube gasket	012-1204-001			
O-ring	Not required		012-1204-036	
Body adaptor	Not required		004-0481-001	
Threaded body	002-5703-001	002-5703-002	002-5705-001	002-5705-002
Flow piston stop	005-5420-121		Not required	
Flow piston assembly	032-7108-001	032-7109-001	032-7109-002	
Lock nut <sup>①</sup>	010-2107-002	010-2107-003		
Flow disc <sup>②</sup>	Specify model number and serial number			

<sup>①</sup> Use insoluble adhesive on nut when attaching new flow disc.

<sup>②</sup> When actuation flow rate is critical, the entire control **must** be returned to the factory for replacement and recalibration of flow disc.

## 4.6 Model Numbers

### 4.6.1 Model F10

#### MODEL NUMBER CODE

	Mounting Connection	Trim	Magnetic Sleeve	Pressure
F10-1	Carbon Steel	304 and 316 Stainless Steel	316 Stainless Steel	1000 psig @ +450° F (69 bar @ +232° C)
F10-3	304 Stainless Steel	304 and 316 Stainless Steel	316 Stainless Steel	1000 psig @ +450° F (69 bar @ +232° C)
F10-4	316 Stainless Steel	316 Stainless Steel	316 Stainless Steel	1000 psig @ +450° F (69 bar @ +232° C)

On flanged models, standoffs are carbon steel with Model F10-1 and 316 stainless steel on Models F10-3 and F10-4.

#### PIPELINE CONNECTION

Connection Type	Vane Sized for Flow Line				
	2"	4"	6"	8"	10"
2" NPT	D22	D24	D26	D28	D20
2½" 150 lb. ANSI raised face flange	n/a	E54	E56	E58	E50
2½" 300 lb. ANSI raised face flange	n/a	E64	E66	E68	E60
2½" 600 lb. ANSI raised face flange	n/a	E74	E76	E78	E70

Consult factory for flow lines above 10" or larger flange sizes.

#### PNEUMATIC SWITCH MECHANISM AND ENCLOSURE

Switch Description	Maximum Supply Pressure		Maximum Process Temperature		Bleed Orifice Diameter		NEMA 1
	psig	bar	° F	° C	inches	mm	
Series J Bleed Type	100	7	+400	+204	.63	1.6	JGF
	60	4	+400	+204	.94	2.3	JHF
	60	4	+400	+204	.55	1.4	JJF
Series K Non-Bleed	100	7	+400	+204	—	—	KOF
	40	3	+400	+204	—	—	KOH

#### ELECTRIC SWITCH MECHANISM AND ENCLOSURE

Switch Description	Maximum Process <sup>①</sup> Temperature ° F (° C)	One Set Point	NEMA 4X/7/9 Aluminum <sup>② ③</sup>		
			Class I, Div. 1 Grps C & D	Class I, Div. 1 Grp B	ATEX
Series B snap	+250 (+121)	SPDT DPDT	BKB BNB	BKK BNK	BC9 BF9
Series C snap	+450 (+232)	SPDT DPDT	CKB CNB	CKK CNK	CC9 CF9
Series D snap for DC current applications	+250 (+121)	SPDT DPDT	DKB DNB	DKK DNK	DC9 DF9
Series HS 5 amp hermetically sealed snap with wiring leads	+450 (+232)	SPDT DPDT	HMJ HMS	HMK HMT	n/a n/a
Series HS 5 amp hermetically sealed snap with terminal block	+450 (+232)	SPDT DPDT	HM3 HM7	HM4 HM8	HA9 HB9

① Process temperatures based on +100° F (+38° C) ambient.

② Uncontrolled housing heater or drain available in NEMA 4X/7/9 enclosures.

③ Consult factory for NEMA 4X/7/9 cast iron housings.

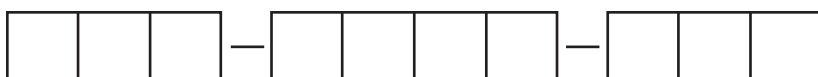

## 4.6.2 Model F50

### MODEL NUMBER CODE

	Body	Trim	Magnetic Sleeve	Pressure Ratings
F50-1	Bronze	300 Series Stainless Steel	400 Series Stainless Steel	400 psi @ +100° F (27.6 bar @ 38° C) 200 psi @ +500° F maximum (13.8 bar @ 260° C maximum)
F50-4	316 Stainless Steel	316 Stainless Steel	316 Stainless Steel	1150 psi @ +100° F (79.2 bar @ 38° C) 600 psi @ +750° F maximum (41.3 bar @ 399° C maximum)

### PIPE SIZE

A2	¾" pipe size with ¾" NPT connections
B2	1" pipe size with 1" NPT connections
C2	1½" pipe size with 1½" NPT connections
D2	2" pipe size with 2" NPT connections

### ACTUATING FLOW RATE

Pipe size	Actuating Flow Rate, GPM Water Flow, Increasing and Decreasing Rate					
	A	B	C	D	E	F
¾" NPT	n/a	1.1 increasing	1.6 increasing	2.3 increasing	3.4 increasing	4.9 increasing
	n/a	0.8 decreasing	1.2 decreasing	1.8 decreasing	2.6 decreasing	3.7 decreasing
1" NPT	1.0 increasing	1.7 increasing	2.5 increasing	3.7 increasing	5.5 increasing	7.1 increasing
	0.8 decreasing	1.4 decreasing	2.1 decreasing	3.0 decreasing	4.5 decreasing	5.8 decreasing
1½" NPT	1.3 increasing	2.7 increasing	4.7 increasing	7.6 increasing	12.3 increasing	21.1 increasing
	1.1 decreasing	2.3 decreasing	4.0 decreasing	6.5 decreasing	10.3 decreasing	17.9 decreasing
2" NPT	1.9 increasing	3.1 increasing	5.1 increasing	8.4 increasing	14.3 increasing	24.8 increasing
	1.6 decreasing	2.7 decreasing	4.3 decreasing	7.1 decreasing	12.1 decreasing	21.0 decreasing

### PNEUMATIC SWITCH MECHANISM AND ENCLOSURE

Switch Description	Max. <sup>①②</sup> Process Temp. ° F (° C)	Maximum Supply Pressure	Bleed Orifice Diameter	Body Material	Pipe Size (NPT)	Flow Rate	NEMA 1	
Series J bleed type	+550 (+288)	100 psig (7 bar)	0.63" (1.6 mm)	Bronze	¾" or 1"	A thru F	JDG	
				Stainless Steel	1½" or 2"	A thru D	JDE	
					¾" thru 2"	E and F		
		Bronze	¾" or 1"	A thru F	JEG			
			1½" or 2"	A thru D	JEE			
				E and F				
Stainless Steel	¾" thru 2"	A thru F						
	Series K non-bleed type	+550 (+288)	100 psig (7 bar)	n/a	Bronze	1½" or 2"	E and F	KOE
					Stainless Steel	¾" thru 1"	A thru F	
Bronze	¾" thru 1"	A thru F	KOG					
1½" or 2"	A thru D							

- ① Process temperatures based on -40° to +160° F (-40° to +71° C).
- ② Bronze models are rated to a maximum process temperature of +500° F (+260° C). Stainless steel models are limited to the maximum temperature of the selected switch mechanism.
- ③ On steam applications, temperature down-rated to +400° F (+204° C) process at +100° F (+40° C) ambient.
- ④ On models with bronze bodies ¾" or 1" NPT pipe sizes, consult factory for HS switches.



## 4.6.2 Model F50 (continued)

### ELECTRIC SWITCH MECHANISM AND ENCLOSURE

Switch Description	Maximum Process Temperature Range <sup>① ②</sup> ° F (° C)	One Set Point	Body Material	Pipe Size (NPT)	Flow Rate	TYPE 4X/7/9 Aluminum		
						Class I, Div 1 Grps C & D	Class I, Div 1 Grp B	ATEX
Series B snap	-40 to +250 (-40 to +121)	SPDT	Bronze	¾" or 1"	A thru F	BKP	BKT	BAC
				1½" or 2"	A thru D E and F			
			Stainless Steel	¾" thru 2"	A thru F	BKQ	BKS	BA9
		DPDT	Bronze	¾" or 1"	A thru F	BNP	BNT	BBC
				1½" or 2"	A thru D E and F			
			Stainless Steel	¾" thru 2"	A thru F	BNQ	BNS	BB9
Series C snap	-40 to +450 (-40 to +232)	SPDT	Bronze	¾" or 1"	A thru F	CKP	CKT	CAC
				1½" or 2"	A thru D E and F			
			Stainless Steel	¾" thru 2"	A thru F	CKQ	CKS	CA9
		DPDT	Bronze	¾" or 1"	A thru F	CNP	CNT	CBC
				1½" or 2"	A thru D E and F			
			Stainless Steel	¾" thru 2"	A thru F	CNQ	CNS	CB9
Series D snap for DC current applications	-40 to +250 (-40 to +121)	SPDT	Stainless Steel	¾" thru 2"	A thru F	DKQ	DKS	DA9
		DPDT			DNQ	DNS	DB9	
Series F snap	-40 to +750 (-40 to +399)	SPDT	Bronze	¾" or 1"	A thru F	FKP	FKT	FAC
				1½" or 2"	A thru D E and F			
			Stainless Steel	¾" thru 2"	A thru F	FKQ	FKS	FA9
		DPDT	Bronze	¾" or 1"	A thru F	FNP	FNT	FBC
				1½" or 2"	A thru D E and F			
			Stainless Steel	¾" thru 2"	A thru F	FNQ	FNS	FB9
Series HS snap 5 amp hermetically sealed w/wiring leads	-50 to +550 (-46 to +288) <sup>③</sup>	SPDT	Bronze	1½" thru 2" <sup>④</sup>	A thru F	HMC	HEK	n/a
		DPDT	Bronze	1½" thru 2" <sup>④</sup>	A thru F	HMF	HET	n/a
Series HS snap 5 amp hermetically sealed w/terminal block	-50 to +550 (-46 to +288) <sup>③</sup>	SPDT	Bronze	1½" thru 2" <sup>④</sup>	A thru F	HM3	HM4	HA9
		DPDT	Bronze	1½" thru 2" <sup>④</sup>	A thru F	HM7	HM8	HB9

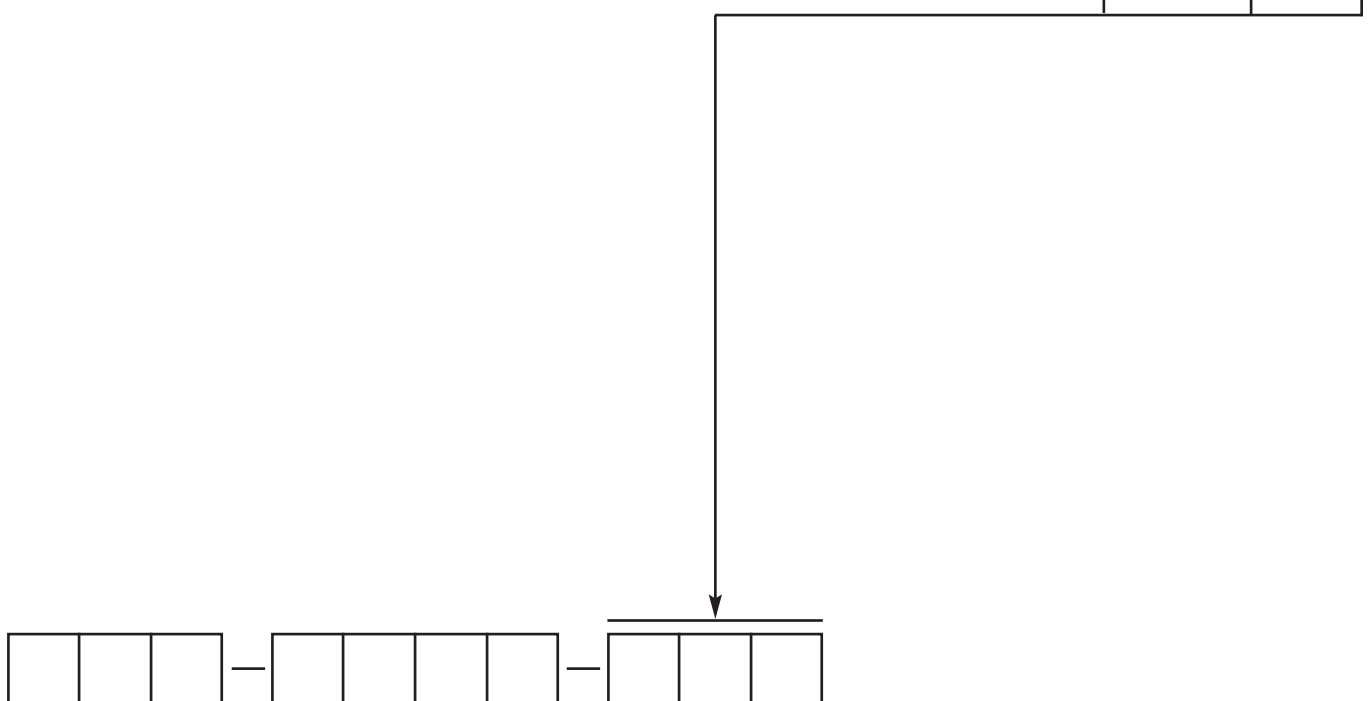

### Service Policy

Owners of Magnetrol may request the return of a control or any part of a control for complete rebuilding or replacement. They will be rebuilt or replaced promptly. Controls returned under our service policy must be returned by Prepaid transportation. Magnetrol will repair or replace the control at no cost to the purchaser (or owner) other than transportation if:

1. Returned within the warranty period; and
2. The factory inspection finds the cause of the claim to be covered under the warranty.

If the trouble is the result of conditions beyond our control; or, is NOT covered by the warranty, there will be charges for labor and the parts required to rebuild or replace the equipment.

In some cases it may be expedient to ship replacement parts; or, in extreme cases a complete new control, to replace the original equipment before it is returned. If this is desired, notify the factory of both the model and serial numbers of the control to be replaced. In such cases, credit for the materials returned will be determined on the basis of the applicability of our warranty.

No claims for misapplication, labor, direct or consequential damage will be allowed.

### Return Material Procedure

So that we may efficiently process any materials that are returned, it is essential that a "Return Material Authorization" (RMA) number be obtained from the factory, prior to the material's return. This is available through Magnetrol local representative or by contacting the factory. Please supply the following information:

1. Company Name
2. Description of Material
3. Serial Number
4. Reason for Return
5. Application

Any unit that was used in a process must be properly cleaned in accordance with OSHA standards, before it is returned to the factory.

A Material Safety Data Sheet (MSDS) must accompany material that was used in any media.

All shipments returned to the factory must be by prepaid transportation.

All replacements will be shipped F.O.B. factory.



5300 Belmont Road • Downers Grove, Illinois 60515-4499 • 630-969-4000 • Fax 630-969-9489 • [www.magnetrol.com](http://www.magnetrol.com)  
145 Jardin Drive, Units 1 & 2 • Concord, Ontario Canada L4K 1X7 • 905-738-9600 • Fax 905-738-1306  
Heikensstraat 6 • B 9240 Zele, Belgium • 052 45.11.11 • Fax 052 45.09.93  
Regent Business Ctr., Jubilee Rd. • Burgess Hill, Sussex RH15 9TL U.K. • 01444-871313 • Fax 01444-871317

Copyright © 2010 Magnetrol International, Incorporated. All rights reserved. Printed in the USA.  
CSA logotype is a registered trademark of Canadian Standards Association

**BULLETIN: 47-602.26**  
**EFFECTIVE: August 2010**  
**SUPERSEDES: August 2008**