



MAGNETROL  
REGISTERED TO  
**ISO 9001**  
Your Assurance of  
Quality and Service

## Modulelevel® Pneumatic and APM Liquid Level Control

Modulelevel pneumatic liquid level controls are displacement actuated level sensors that provide output signals in direct proportion to changes in liquid level.

Simple modular design and Magnetrol's proven magnetic coupling make Modulelevel controls versatile, highly stable, vibration resistant and adaptable to extremes in temperature and pressure.

### Features

- Standard models handle service temperatures from -150° F to +700° F (-101° C to +371° C) and pressure to 4265 PSIG (318 Bar).
- Stable output signal is unaffected by surface turbulence. Prevents control valve "hunting" and extends valve life.
- Controller head may be removed without disturbing pressure boundary. Permits service or replacement without shutdown of process.
- Simple calibration prior to installation, by substituting weights for displacer or by controller head calibration with displacer.
- Accurate output signal provided over a wide specific gravity range.
- Controller head rotates 360°, simplifies pneumatic piping hookup.
- 316 SS displacer and trim. Inconel & 316SS range springs.
- Easily calibrated without moving tank liquid level, for reduced installation time and cost.
- Pilot relay provides a 4 to 1 amplification of pilot pressure signal to speed valve response.
- Built-in visual level indicator is independent of air supply.
- Optional pneumatic-to-current interface transducer for use in electronic control applications.
- Optional proportional plus integral control.
- Optional differential gap (on-off) control.
- Optional High-Low electronic alarm signal provides inexpensive backup alarm.
- Fabricated construction.

### Applications

Modulelevel pneumatic liquid level controls are widely used in utility power generation, chemical and petroleum processing operations, such as:

- Steam generator feedwater heater regulation
- Fractionating column level transmitter
- Ethanolamine level transmitter
- Vent gas scrubber level control
- Drip pot condensate level control
- Flash tank level transmitter
- Boiler level control



## Principle of operation

The key elements of the Modulelevel pneumatic control are the magnetic coupling, which allows the controller to be mechanically isolated from the sealed sensing unit; the range spring, which dampens the action of the displacer; and the controller head, which provides a modulated pneumatic signal in direct proportion to the input from the vertical motion of the displacer.

As the liquid level in the vessel increases or decreases, the buoyant displacer rises or falls. This motion, dampened by the action of the range spring to prevent response to the rapid fluctuations of turbulence, is mechanically coupled to an attractor ball, within an enclosed tube.

A magnet encircling the tube follows the attractor ball, transferring the motion to a rotating cam, which in turn operates a flapper against a nozzle which increases or decreases the pressure within the pneumatic relay. The output pressure signal can be used in a variety of ways to operate a control valve or signal to alarms, indicators, process controls or other devices.

With optional integral control, the pilot nozzle proportional signal is conditioned through an additional metering valve system, which will eliminate offset from the desired control point.

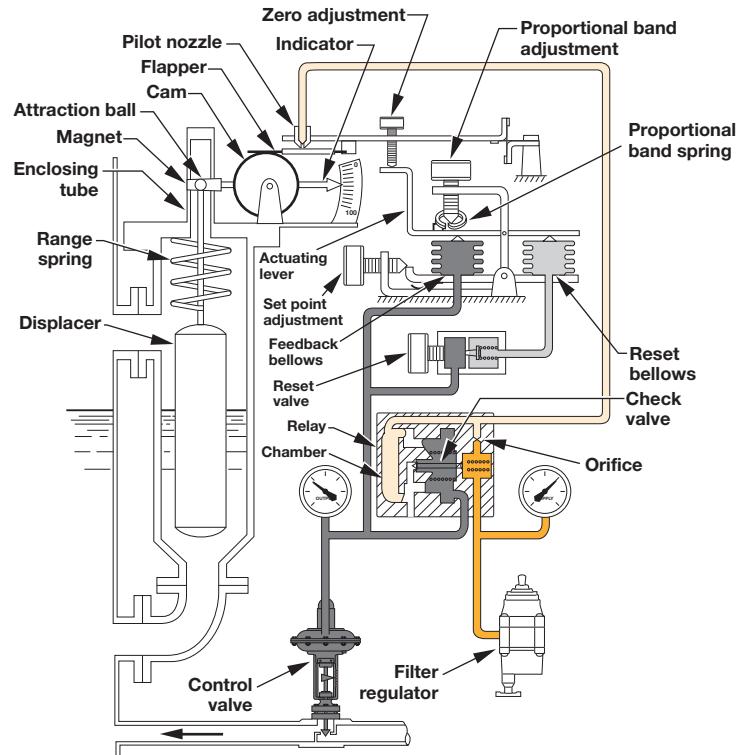

## Specifications

Description		Specification
Process pressure		Up to 4265 PSIG at 100° F (Up to 318 bar at 38° C)
Process temperature		Stainless steel cage -150° to +700° F (-101° to +371° C) Carbon steel cage -20° to +700° F (-29° to +371° C)
Specific gravity range		Minimum: 0.11 Maximum: 2.20
Interface detection		Minimum difference of 0.10 specific gravity between liquids
Process connections		NPT, Socket Weld or Flanged
Supply pressure*		250 PSIG (17 bar) max. to regulator Instrument quality air (clean and dry) Regulator set to 5 PSIG (.3 bar) above maximum output.
Output signal pressure	Proportional & transmitter	3-15 PSIG, 6-30 PSIG
	Differential gap	0-20 PSIG or 0-35 PSIG
Visual Indicator		% Span
Level range & proportional band adjustment		Limited only to displacer length. From fractional inches to 10 feet (3 meters).
Air consumption		3 SCFH at 9 PSIG output 6 SCFH at 15 PSIG output
Response speed		100 cu. in. output volume in 3.2 sec. upon an output pressure increase from 3-15 PSIG.
Wetted parts		Trim: 304 or 316 SS Spring: 316 SS or Inconel Chamber: Carbon steel or 316 SS
Control action		Direct or reverse
Modes of operation		Proportional control, Differential gap, Transmitter
Housing		NEMA 1, 2, 3, and 3R
Limit switch ratings		Max. voltage: 120 VAC/VDC Max. resistive load: 10 VAC/VDC Max. current: 1/4 amp switching 1 amp holding

\*Maximum supply pressure with customer supplied regulator is 100 PSIG (7 bar).

## Options

Consult the factory when ordering any of the options listed below.

### Filter regulator and gauge

Modulelevel instruments require filtered air of the correct pressure for operation. Filter regulators may be either field or factory supplied. Filter regulators and gauges are ordered as separate items using the part numbers listed below:

Filter Regulator	06-9501-002
Gauge	06-9501-003

### Adjustable hanger

An adjustable stainless steel suspension cable is available for flanged top-mounting models. Standard length cable is 8 feet (2.4 meters). A cable is ordered as a separate item using the part number listed below:

Adjustable hanger	32-3110-001
-------------------	-------------

### Special process connections

Special process connections are available for retrofit applications.

### Gauge glass tappings

Gauge glass tappings are available on all caged models. Specify the location and distance between the tappings when placing an order.

### P/I converters

P/I converters are available on all Modulelevel controls. These units can provide a 4-20 mA or 10-50 mA two-wire output signal from the Modulelevel transmitter's input air signal of either 3-15 PSIG or 6-30 PSIG.

## Mounting arrangements

### Flanged top P51, P61 and P62 displacer models

For mounting on top of the tank, flanged top models are available. They are used extensively in interface control applications where non-standard size displacers become necessary. An adjustable stainless steel displacer suspension cable is also available. Top mounting models are directly interchangeable with the external cage models. Choose from carbon steel or stainless steel models. A heavy duty model, suitable for pressures up to 4265 PSIG at +100° F (318 bar at +38° C), is also available.

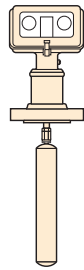

**P61 Flanged Top Model**

### Top Mounted APM-131

When mounting inside the tank is possible, threaded top models are the answer. An adjustable stainless steel displacer suspension cable is provided as standard.

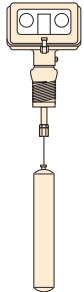

**Top Mounted APM-131**

### External cage P53, P55, P63, P64, P65, P66, P71 and P72 displacer models

External cage models can be easily isolated from the process for maintenance and inspection operations. The modern in-line design eliminates the need for specifying right hand and left hand. Any mounting position is possible by rotating the instrument head. A variety of models are available including sealed or flanged cage with either side/side or side/bottom connections. Choose carbon steel or stainless steel models. Heavy duty models, suitable for pressures up to 4265 PSIG at +100° F (318 bar at +38° C), are also available.

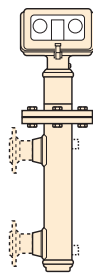

**P65 External Cage Model with Side/Side Connections**

### External cage APM-W251, APM-W254 and APM-W291

External cage models can be easily isolated from the process to simplify maintenance and inspection operations. Sight glass and Try-cock tappings are provided.

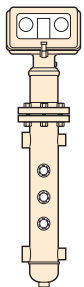

**External Cage APM-W251**

### Side mounted P68 float model

Side mounted models are ideally suited for narrow level range applications. Carbon steel models are available with either a 3" NPT threaded body or a 4" flanged connection. This model is suitable for pressures up to 800 PSIG at +100° F (55 bar at +38° C).

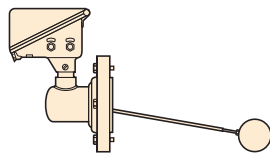

## Modulevel® pneumatic instruments

Modulevel pneumatic instruments are available in a variety of functions and styles to handle different application requirements.

### Proportional

Proportional instruments are used to maintain the level in a tank within a pre-determined band. The output from the Modulevel head controls the opening and closing of a valve to control the increase or decrease of the liquid flow through the vessel.

### Proportional integral

Proportional integral instruments (i.e., with reset) operate in the same manner as the proportional with one major difference. The offset between the desired level and the actual process level is eliminated; thus, maintaining the level at a specific point rather than within a band.

### Transmitter

Transmitters are adjusted for full level range operation and signal the current liquid level. The signal can be fed to a variety of devices as the application requires.

### Differential gap

A differential gap instrument provides only two distinct outputs; either, fully opened or fully closed. One distinct output value is obtained when the level exceeds the upper switching point. This output remains constant until the level decreases below the lower switching point. At this time the controller changes to another distinct output value. The new value remains constant until the level again rises above the upper switching point; causing the output value to return to the first output value. The distance between the two switching points is called the differential gap.

### Transmitter/Receiver controller

There are two devices in this version. The first is a transmitter which senses the level directly at the vessel and provides a 100% of span signal to the receiver/controller. The receiver/controller operates in the same manner as a direct connected level device, such as a proportional controller, which allows varying the proportional band and level set point. This unit may be mounted either integrally next to the transmitter, or at a more convenient remote location.

### Direct acting

As the level increases, the pressure increases in direct acting pneumatic instruments.

### Electric limit switches

Electric limit switches allow high and low alarms to be added to any of the pneumatic instruments described above.

### Reverse acting

As the level increases, the pressure decreases in reverse acting pneumatic instruments.

## Interface detection

Modulevel controllers can be factory calibrated to detect the interface between two liquids if:

1. There is a minimum difference in specific gravity of 0.10.
2. The interface line between the two liquids is kept within the length of the displacer.
3. The displacer is constantly submerged in liquid.

Consult the factory when specifying units for interface applications. The specific gravity of both liquids must be supplied at the time the order is placed.

## Expedite ship plan (ESP)

Many standard Module level pneumatic level controls are available for quick shipment, usually within one week after factory receipt of a purchase order, through the Expedite Ship Plan (ESP). Models covered by ESP service are conveniently color coded in the selection data charts which follow. To take advantage of ESP, simply match color coded model number codes and options (standard dimensions apply). ESP service may not apply to orders of ten units or more. Contact your local representative for lead times on larger value orders as well as other products and options.

### Selection data

Module level controls are identified by a ten digit alphanumeric model numbering system. The model number describes model configuration, materials of construction, level ranges, and other options vital to the performance and function of the instrument.

**Example:** P63-5C5A-PAA

## Model number construction

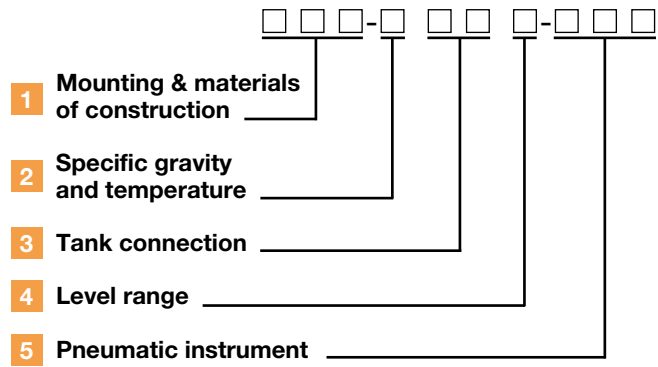

## Standard flanged cage displacer models

### 1 Mounting and materials of construction

Model	Style	Mounting Arrangement	Body Material	Pressure
P61	In Tank	Top ①	Carbon Steel	ANSI 150, 300, 600 lb.
P62			316SS	
P63	External Flanged Cage	Side/Bottom	Carbon Steel	
P64			316 SS	
P65		Side/Side	Carbon Steel	
P66			316 SS	

① Requires adjustable hanger, part number 032-3110-001, when the span is greater than 5.00" (127 mm) below the mounting flange.

### 2 Specific gravity and temperature

Liquid Specific Gravity Range	Code ②	
	400° F (204° C) Max.	700° F (371° C) Max.
0.23 — 0.54	1	4
0.55 — 1.09	2	5
1.10 — 2.20	3	6

② Inconel spring furnished on models P62, P64, and P66 with codes 4, 5, and 6.

### 5 Pneumatic instrument

Function	Pressure PSIG	Single Function Models				Transmitter/Receiver Controllers			
		Direct Acting		Reverse Acting		Integral Mount		Remote Mount	
		Standard Head	w/Limit Switches	Standard Head	w/Limit Switches	Direct Acting	Reverse Acting	Direct Acting	Reverse Acting
						Standard	Standard	Standard	Standard
Proportional	3-15	PAA	PIA	PEA	PMA	RAA	REA	TAA	TEA
	6-30	PAB	PIB	PEB	PMB	RAB	REB	TAB	TEB
Proportional w/reset	3-15	PBA	PJA	PFA	PNA	RBA	RFA	TBA	TFA
	6-30	PBB	PJB	PFB	PNB	RBB	RFB	TBB	TFB
Transmitter	3-15	PCA	PKA	PGA	POA	—	—	—	—
	6-30	PCB	PKB	PGB	POB	—	—	—	—
Differential gap	0-20	PDA	PLA	PHA	PPA	—	—	—	—
	0-35	PDB	PLB	PHB	PPB	—	—	—	—

For explanations of the various types of pneumatic instruments, refer to page 3.

### 3 Tank connection

Model	Pipe Size	Mounting Connection Code ANSI Head Flange Rating		
		150 lb.	300 lb.	600 lb.
P61, P62	3 inch	G3	G4	G5
	4 inch	H3	H4	H5
	6 inch	K3	K4	K5

Model	Pipe Size	Connection Style	Mounting Connection Code ANSI Head Flange Rating		
			150 lb.	300 lb.	600 lb.
P63, P64, P65, P66	1½"	NPT	C5	C7	C9
		Socket Weld	C6	C8	C0
		Flanged	P3	P4	P5
	2"	NPT	D5	D7	D9
		Socket Weld	D6	D8	D0
		Flanged	Q3	Q4	Q5

### 4 Level range/displacer diameter

Code	A	B	C	D	E	F	G	H	I
Inches	14.0	32.0	48.0	60.0	72.0	84.0	96.0	108.0	120.0
mm	356	813	1219	1524	1829	2134	2438	2743	3048
Dia.	2.0	1.25	1.0	.88	.88	.75	.75	.63	.63
mm	50	31	25	22	22	19	19	16	16

## Selection data

Module level controls are identified by a ten-digit alphanumeric model numbering system. The model number describes model configuration, materials of construction, level ranges and other options vital to the performance and function of the instrument.

**Example:** P51-5H6A-PAA

## Model number construction

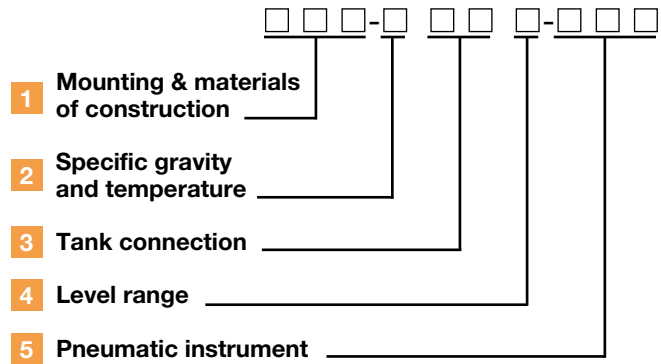

## High pressure flanged cage displacer models

### 1 Mounting and materials of construction

Model ①	Style	Mounting Arrangement	Body Material	Pressure
P51	In Tank	Top ②	Carbon Steel	ANSI 900, 1500, 2500 lb. ③
P53	External Flanged Cage	Side/Bottom		
P55		Side/Side		

① P50 Series displacer material 304 stainless steel.

② Requires adjustable hanger, part number 032-3110-001, when the span is greater than 9.31" (236 mm) below the mounting flange.

### 2 Specific gravity and temperature

Liquid Specific Gravity Range	Code 700° F (371° C) Maximum
0.55 — 1.09	5

### 3 Tank connection

Model	Pipe Size	Mounting Connection Code ANSI Head Flange Rating		
		900 lb.	1500 lb.	2500 lb. ③
P51	4 inch	H6	H7	H8

Model	Pipe Size	Connection Style	Mounting Connection Code ANSI Head Flange Rating		
			900 lb.	1500 lb.	2500 lb. ③
P53, P55	1½"	NPT	L5	L7	L9
		Socket Weld	M5	M7	M9
		Flanged	P6	P7	P8
	2"	NPT	L6	L8	L0
		Socket Weld	M6	M8	M0
		Flanged	Q6	Q7	Q8

③ Maximum rating for a unit with 2500 lb. flanges is 4265 PSIG at +100° F (294 bar at +38° C).

### 4 Level range/displacer diameter

Code	A	B	C	D
Inches	14.0	32.0	48.0	60.0
mm	356	813	1219	1524
Dia.	1.90	1.25	1.0	.88
mm	48	31	25	22

### 5 Pneumatic instrument

Function	Pressure PSIG	Single Function Models				Transmitter/Receiver Controllers			
		Direct Acting		Reverse Acting		Integral Mount		Remote Mount	
		Standard Head	w/Limit Switches	Standard Head	w/Limit Switches	Direct Acting	Reverse Acting	Direct Acting	Reverse Acting
						Standard	Standard	Standard	Standard
Proportional	3-15	PAA	PIA	PEA	PMA	RAA	REA	TAA	TEA
	6-30	PAB	PIB	PEB	PMB	RAB	REB	TAB	TEB
Proportional w/reset	3-15	PBA	PJA	PFA	PNA	RBA	RFA	TBA	TFA
	6-30	PBB	PJB	PFB	PNB	RBB	RFB	TBB	TFB
Transmitter	3-15	PCA	PKA	PGA	POA	—	—	—	—
	6-30	PCB	PKB	PGB	POB	—	—	—	—
Differential gap	0-20	PDA	PLA	PHA	PPA	—	—	—	—
	0-35	PDB	PLB	PHB	PPB	—	—	—	—

For explanations of the various types of pneumatic instruments, refer to page 3.

## Selection data

Module level controls are identified by a ten digit alphanumeric model numbering system. The model number describes model configuration, materials of construction, level ranges and other options vital to the performance and function of the instrument.

**Example:** P71-1C9A-PAA

## Standard sealed cage displacer models

### 1 Mounting and materials of construction

Model	Style	Mounting Arrangement	Body Material	Pressure
P71	External Sealed Cage	Side/Bottom	Carbon Steel	ANSI 150, 300 (*600 lb.)
P72		Side/Side		

\*For 600 lb. pressure rating, refer to chart at right.

### 2 Specific gravity and temperature

Liquid Specific Gravity Range	Code ①	
	+400° F (+204° C) Max.	+700° F (+371° C) Max.
0.23 — 0.54	1	4
0.55 — 1.09	2	5
1.10 — 2.20	3	6

### 3 Tank connection

Model	Pipe Size	Mounting Connection Code				
		NPT	Socket Weld	ANSI Mounting Flange Rating		
				150 lb.	300 lb.	600 lb.
P71, P72	1½"	C9	C0	P3	P4	P5
	2"	D9	D0	Q3	Q4	Q5

### 5 Pneumatic instrument

Function	Pressure PSIG	Single Function Models				Transmitter/Receiver Controllers			
		Direct Acting		Reverse Acting		Integral Mount		Remote Mount	
		Standard Head	w/Limit Switches	Standard Head	w/Limit Switches	Direct Acting	Reverse Acting	Direct Acting	Reverse Acting
						Standard	Standard	Standard	Standard
Proportional	3-15	PAA	PIA	PEA	PMA	RAA	REA	TAA	TEA
	6-30	PAB	PIB	PEB	PMB	RAB	REB	TAB	TEB
Proportional w/reset	3-15	PBA	PJA	PFA	PNA	RBA	RFA	TBA	TFA
	6-30	PBB	PJB	PFB	PNB	RBB	RFB	TBB	TFB
Transmitter	3-15	PCA	PKA	PGA	POA	—	—	—	—
	6-30	PCB	PKB	PGB	POB	—	—	—	—
Differential gap	0-20	PDA	PLA	PHA	PPA	—	—	—	—
	0-35	PDB	PLB	PHB	PPB	—	—	—	—

For explanations of the various types of pneumatic instruments, refer to page 3.

## Model number construction

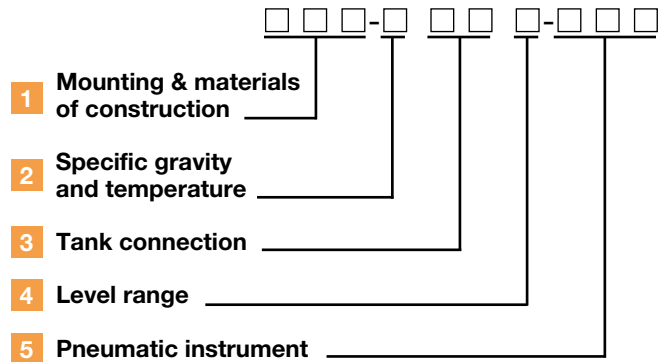

### 4 Level range/displacer diameter

Code	A	B	C	D	E	F	G	H	I
Inches	14.0	32.0	48.0	60.0	72.0	84.0	96.0	108.0	120.0
mm	356	813	1219	1524	1829	2134	2438	2743	3048
Dia.	2.00	1.25	1.0	.88	.88	.75	.75	.63	.63
mm	50	31	25	22	22	19	19	16	16

### NPT, socket weld, and 600 lb. pressure/temperature ratings

Temperature ②		Pressure	
° F	° C	PSIG	Bar
100	38	1440	99
200	93	1240	85
300	149	1120	77
400	204	1020	70
500	260	940	65
600	315	900	62
700	371	860	59

## Selection data

Module level controls are identified by a ten-digit alphanumeric model numbering system. The model number describes model configuration, materials of construction, level ranges and other options vital to the performance and function of the instrument.

**Example:** P68-2F2A-PAJ

### Standard side mounted float models

#### 1 Mounting and materials of construction

Model	Style	Mounting Arrangement	Body Material	Float & Trim	Pressure
P68*	In-Tank	Side	Carbon Steel	316 SS	ANSI 150, 300, 600 Lb.

\*Maximum pressure rating with 600 lb. flange is 800 psi at 100° F.

#### 2 Specific gravity and temperature

Liquid Specific Gravity Range	Code +400° F (+204° C) Max.
0.60 minimum	2

#### 3 Tank connection and level range

Model	Pipe Size	Mounting Connection Code			
		NPT	ANSI Mounting Flange Rating		
			150 Lb.	300 Lb.	600 Lb.
P68	3 Inch	F2A	Not Available		
	4 Inch	N/A	H3A	H4A	H5A

Maximum available level range is 8.50" (216 mm) with 3" NPT and 7.38" (187 mm) with flanged models.

### APM Boiler displacer models

#### 1 Design Type

APM	Pneumatic Level Controls
-----	--------------------------

#### 2 Mounting and materials of construction

Model Code	Output Signal	Mounting Arrangement	Body Material	Maximum Pressure	Maximum Temperature	Minimum S.G.	Displacer Size
131L	3-15	Top	Carbon steel	230 psig (16 bar)	+250° F (+120° C)	0.90	2" x 14"
131H	6-30	Top	Carbon steel	230 psig (16 bar)	+250° F (+120° C)	0.90	2" x 14"
W251	3-15 6-30	External Flange Cage	Cast iron	250 lb. WSP	+406° F (+208° C)	0.86	2.5" x 9"
W254	3-15 6-30	External Flange Cage	Cast iron	250 lb. WSP	+406° F (+208° C)	0.86	2" x 12"
W291	3-15 6-30	External Flange Cage	Carbon steel	300 lb. WSP	+422° F (+217° C)	0.85	2" x 12"

#### 3 Pneumatic instrument

Function	Pressure psig	Single Function Models			
		Direct Acting		Reverse Acting	
		Standard Head	w/Limit Switches	Standard Head	w/Limit Switches
Proportional	3-15	PAA	PIA	PEA	PMA
	6-30	PAB	PIB	PEB	PMB

## Model number construction

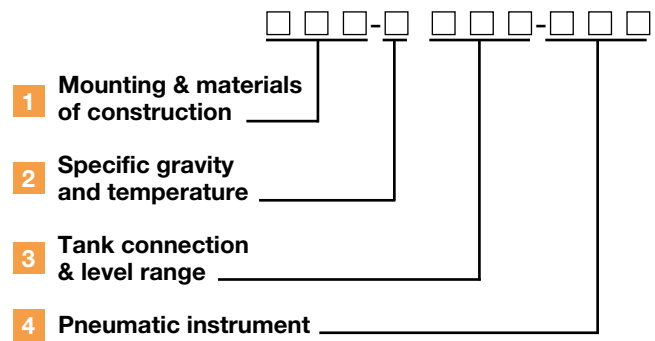

#### 4 Pneumatic instrument

Function	Pressure PSIG	Single Function P68 Models Only Integral Mount	
		Direct Acting	Reverse Acting
		Standard	Standard
Proportional	3-15	PAJ	PEJ
	6-30	PAK	PEK
Proportional w/Reset	3-15	PBJ	PFJ
	6-30	PBK	PFK
Transmitter	3-15	PCJ	PGJ
	6-30	PCK	PGK
Differential Gap	0-20	PDJ	PHJ
	0-35	PDK	PHK

For explanations of the various types of pneumatic instruments, refer to page 3.

## Model number construction

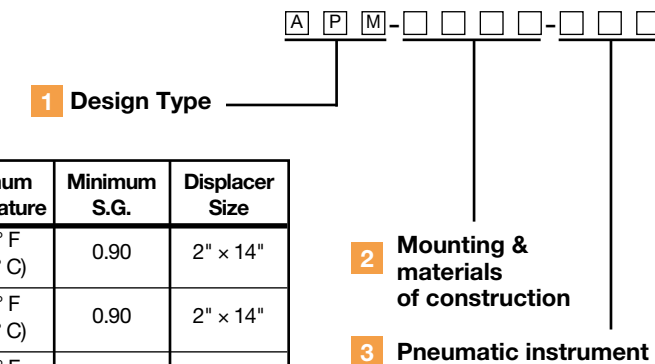

**NOTE:** Controller head may be rotated through 360°.

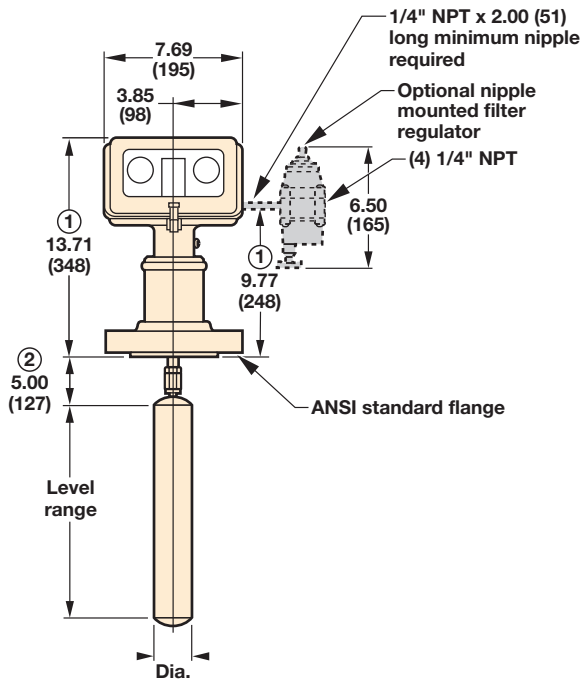

**P61 and P62 Series Top Mounting**  
150, 300, 600 lb. Class

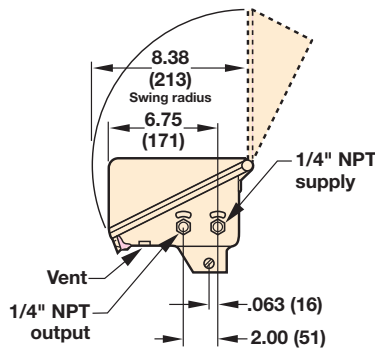

**Controller Head (side view)**

Outlet Size	Dimension A
1½" NPT or Socket Weld	3.22 (82)
2" NPT or Socket Weld	3.34 (85)

Outlet Size	Dimension B
1½" Flanged	5.94 (151)
2" Flanged	6.25 (159)

Outlet Size	Dimension C
1½" or 2", 150 lb.	7.50 (191)
1½" or 2", 300 lb.	8.25 (210)
1½" or 2", 600 lb.	8.25 (210)

- ① Add 1.96 (50) for units with specific gravity code 1, 5.08 (129) for units with specific gravity code 4, and 3.12 (79) for units with specific gravity codes 5 or 6.
- ② Distance without stem extension is 5.00 (127) standard. Can be furnished to a minimum distance of 3.00 (76).

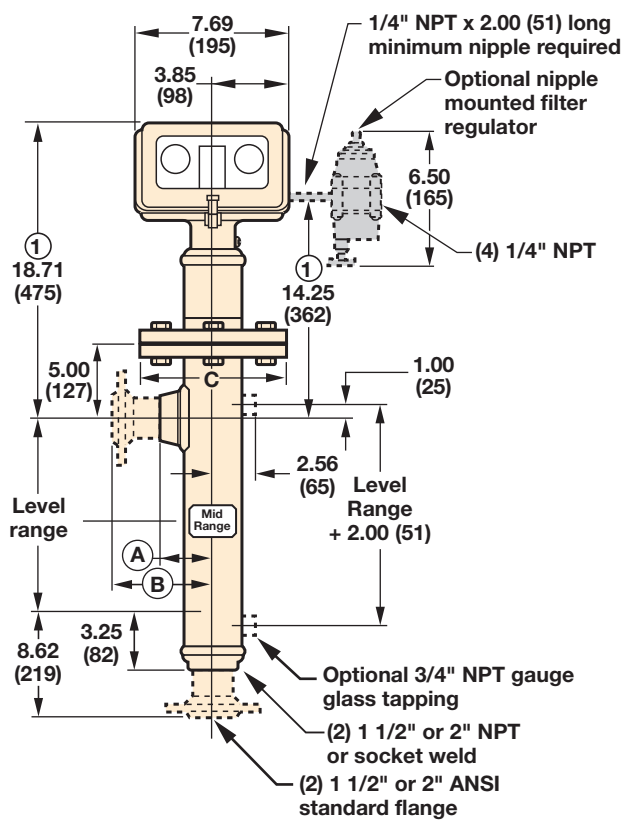

**P63 and P64 Series with Side/Bottom Connections**  
150, 300, 600 lb. Class

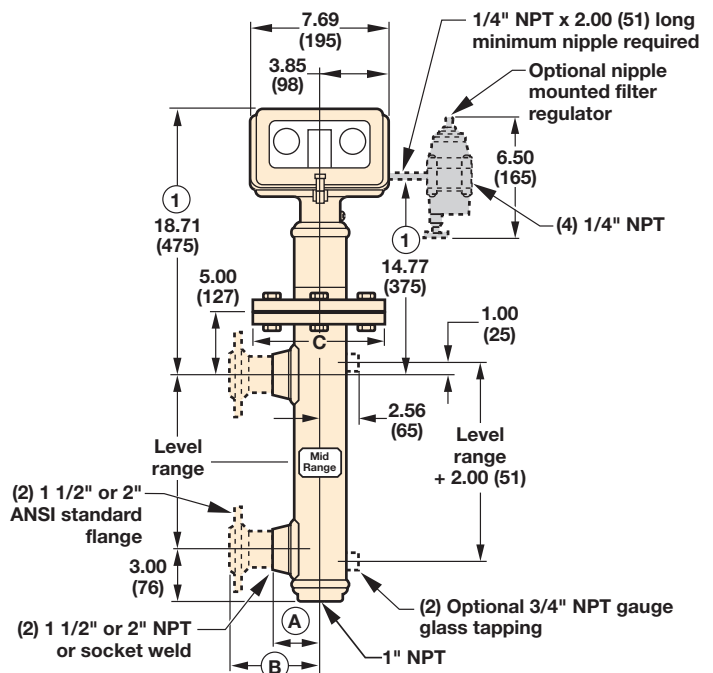

**P65 and P66 Series with Side/Side Connections**  
150, 300, 600 lb. Class

**Dimensional specifications inches (mm)**

**High pressure flanged cage models: P51, P53, P55**

**NOTE:** Controller head may be rotated through 360°.

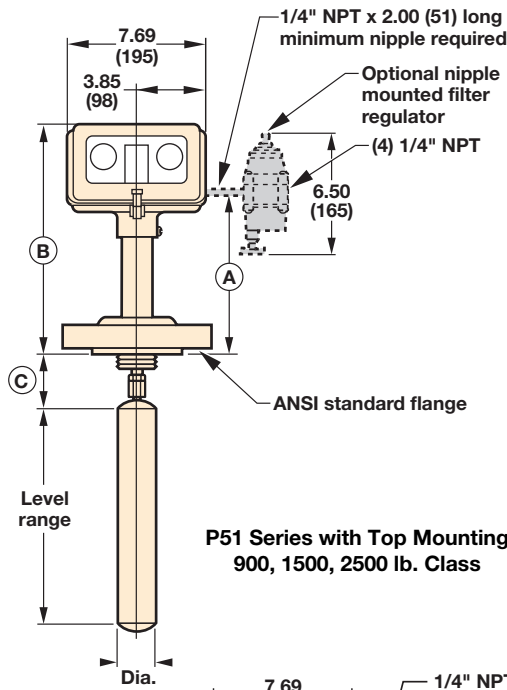

**P51 Series with Top Mounting**  
900, 1500, 2500 lb. Class

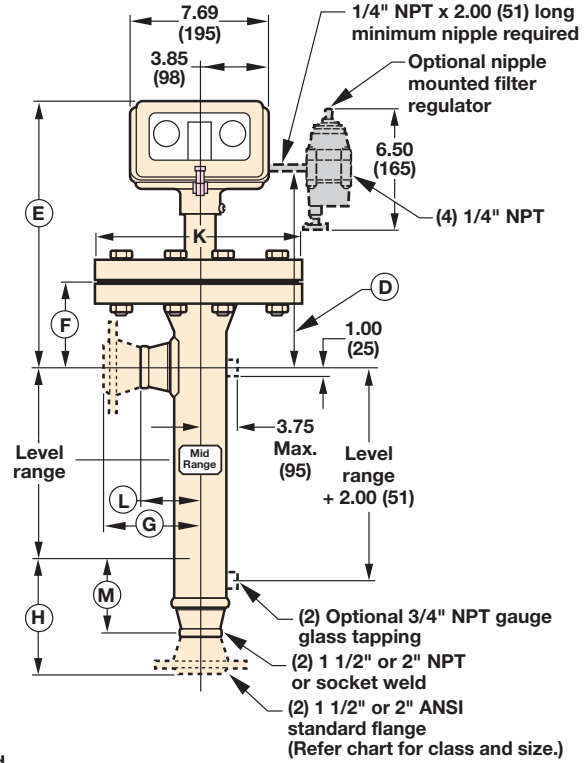

**P53 Series with Upper Side/Bottom Connections**  
900, 1500, 2500 lb. Class

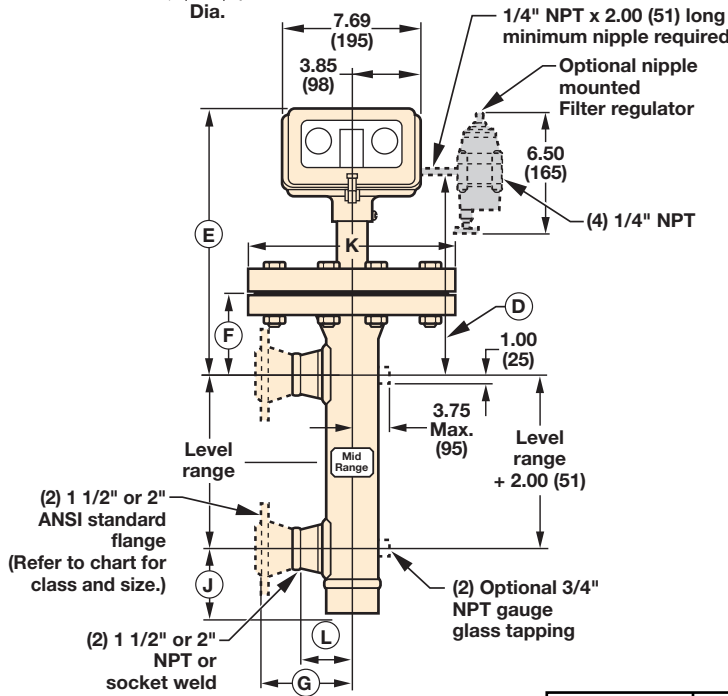

**P55 Series with Side/Side Connections**  
900, 1500, 2500 lb. Class

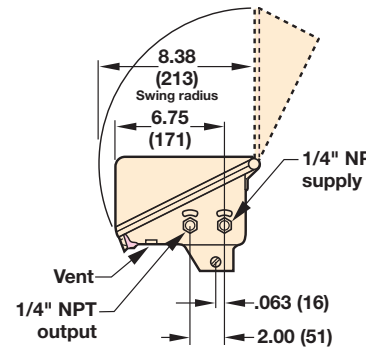

**Controller Head**  
Side View

Outlet Size	Dimensions	
	L	M
1 1/2" NPT or Socket Weld	4.00 (102)	3.44 (87)
2" NPT or Socket Weld	4.38 (111)	3.50 (89)

Flange Size & Class	Dimensions									
	A	B	C	D	E	F	G	H	J	K
1 1/2" - 900 lb.	8.48	12.41	9.31	17.96	21.89	9.31	7.25	8.43	3.44	11.50
	(215)	(315)	(236)	(456)	(556)	(236)	(184)	(214)		
2" - 900 lb.							8.18	9.38		
							(208)	(238)		
1 1/2" - 1500 lb.	8.86	12.79	9.31	18.34	22.27	9.31	7.93	9.13	3.44	12.25
	(225)	(325)	(236)	(466)	(566)	(236)	(201)	(232)		
2" - 1500 lb.							8.87	10.13		
							(225)	(257)		
1 1/2" - 2500 lb.	9.73	13.66	9.31	19.21	23.14	9.31	9.06	10.25	3.44	14.00
	(247)	(347)	(236)	(488)	(588)	(236)	(230)	(267)		
2" - 2500 lb.							9.87	11.13		
							(251)	(283)		

**NOTE:** Controller head may be rotated through 360°.

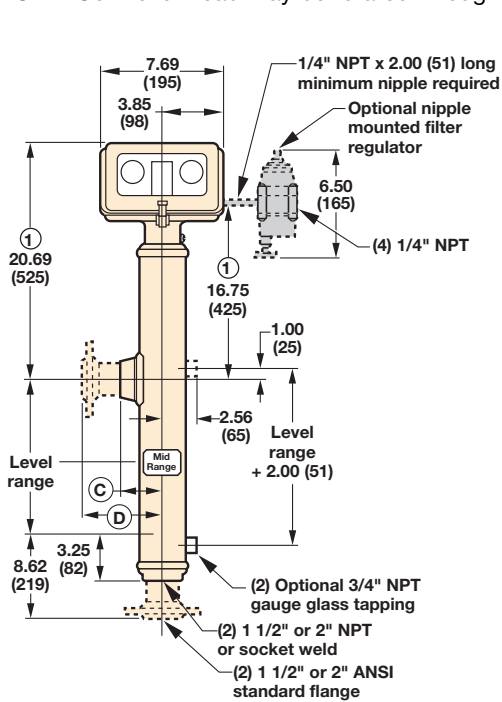

**P71 Series with Upper Side/Bottom Connections**  
150, 300, 600 lb. Class

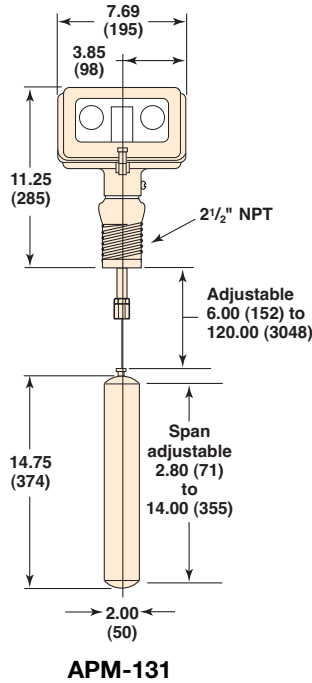

**APM-131**

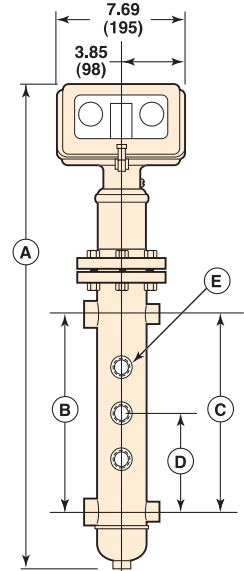

**APM-W251, APM-W254, and APM-W291**

**Controller Head Side View**

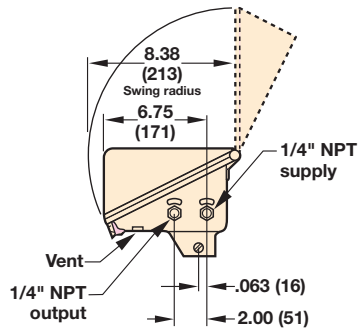

Outlet Size	Dimension C
1 1/2" NPT or Socket Weld	3.22 (82)
2" NPT or Socket Weld	3.34 (85)

Outlet Size	Dimension D
1 1/2" Flange	5.94 (151)
2" Flange	6.25 (159)

① Add 1.96 (50) for units with specific gravity code 1, 5.08 (129) for units with specific gravity code 4, and 3.12 (79) for units with specific gravity codes 5 or 6.

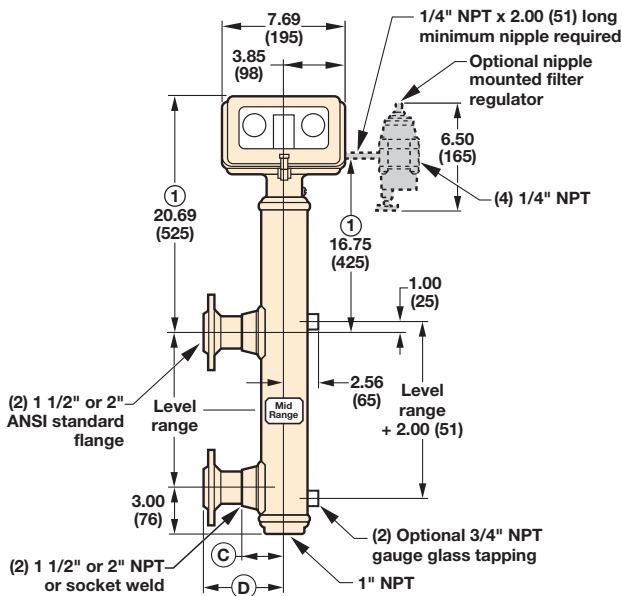

**P72 Series with Side/Side Connections**  
150, 300, 600 lb. Class

Catalog Number	A	B Gauge glass centers and pipe size	C Drum connector centers and pipe size	D Mid range of throttling band	E Try-Cock tappings and pipe size
APM-W251	25.62	13.50 1/2" NPT	13.50 1" NPT	6.00	Three 1/2" NPT
APM-W254	29.50	15.00 3/4" NPT	16.00 1 1/4" NPT	8.00	Six 3/4" NPT
APM-W291	30.50	15.00 3/4" NPT	15.00 1 1/4" NPT	7.50	Three 3/4" NPT

Dimensions are in inches and subject to change without notice. Certified and detailed submittal drawings are available from the factory.

NOTE: Controller head may be rotated through 360°.

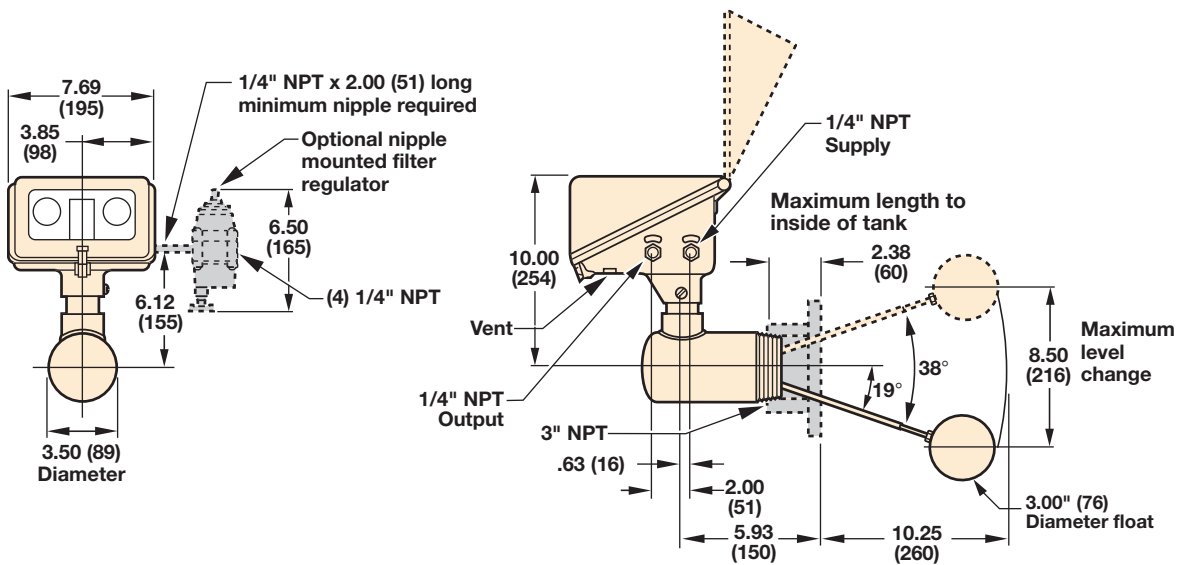

P68 Series with Threaded Side Mounting

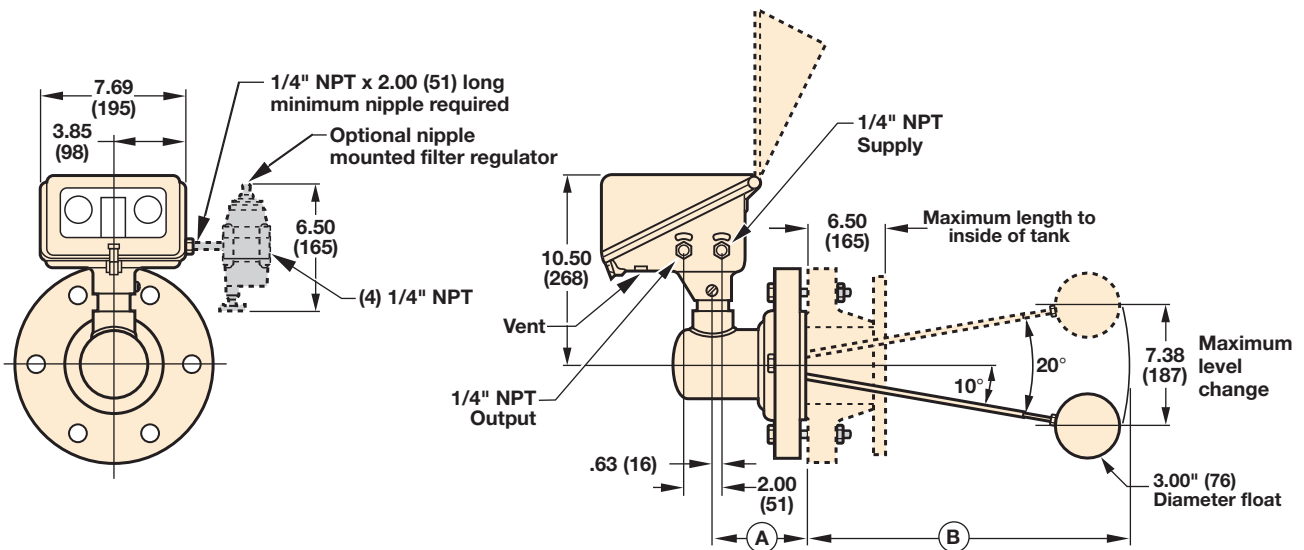

P68 Series with Flanged Side Mounting

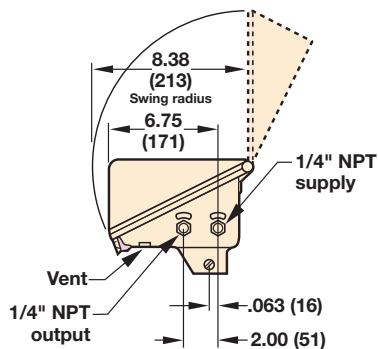

Controller Head Side View

Flange Size and Class	Dim. A	Dim. B	No. of Bolt Holes	Dia. of Bolt Holes
4" - 150 lb.	5.38 (137)	20.12 (511)	8	.75 (19)
4" - 300 lb.	5.38 (137)	20.12 (511)	8	.88 (22)
4" - 600 lb.	5.88 (149)	19.62 (498)	8	1.00 (25)

## Product warranty

All Magnetrol mechanical level and flow controls are warranted free of defects in materials or workmanship for five full years from the date of original factory shipment.

If returned within the warranty period; and, upon factory inspection of the

control, the cause of the claim is determined to be covered under the warranty; then, Magnetrol will repair or replace the control at no cost to the purchaser (or owner) other than transportation.

Magnetrol shall not be liable for misapplication,

labor claims, direct or consequential damage or expense arising from the installation or use of equipment. There are no other warranties expressed or implied, except special written warranties covering some Magnetrol products.

## Quality assurance



The quality assurance system in place at Magnetrol guarantees the highest level of quality throughout the company. Magnetrol is committed to providing full customer satisfaction both

in quality products and quality service.

Magnetrol's quality assurance system is registered to ISO 9001 affirming its commitment to known

international quality standards providing the strongest assurance of product/service quality available.

**ASSURED QUALITY & SERVICE COST LESS**



5300 Belmont Road • Downers Grove, Illinois 60515-4499 • 630-969-4000 • Fax 630-969-9489 • [www.magnetrol.com](http://www.magnetrol.com)  
145 Jardin Drive, Units 1 & 2 • Concord, Ontario Canada L4K 1X7 • 905-738-9600 • Fax 905-738-1306  
Heikensstraat 6 • B 9240 Zele, Belgium • 052 45.11.11 • Fax 052 45.09.93  
Regent Business Ctr., Jubilee Rd. • Burgess Hill, Sussex RH15 9TL U.K. • 01444-871313 • Fax 01444-871317

Copyright © 2007 Magnetrol International, Incorporated. All rights reserved. Printed in the USA.  
Performance specifications are effective with date of issue and are subject to change without notice.

**BULLETIN: 48-110.19**  
**EFFECTIVE: January 2007**  
**SUPERSEDES: January 2001**