

# ES/EZ Modulelevel®

## Top Hat Assembly Design

Installation and Operating Manual



*Digital ES II Modulelevel  
with HART® Communication  
and Analog EZ Modulelevel  
Electronic Liquid Level  
Transmitters*

---

## Read this Manual Before Installing

This manual provides information on the Digital ES II and Analog EZ Modulelevel Electronic Transmitters. It is important that all instructions are read carefully and followed in sequence. Detailed installation, wiring and calibration instructions are included in this manual.

## Conventions Used in this Manual

Certain conventions are used in this manual to convey specific types of information. General technical material, support data, and safety information are presented in narrative form. The following styles are used for notes, cautions, and warnings.

### NOTES

Notes contain information that augments or clarifies an operating step. Notes do not normally contain actions. They follow the procedural steps to which they refer.

### Cautions

Cautions alert the technician to special conditions that could injure personnel, damage equipment, or reduce a component's mechanical integrity. Cautions are also used to alert the technician to unsafe practices or the need for special protective equipment or specific materials. In this manual, a caution box indicates a potentially hazardous situation which, if not avoided, may result in minor or moderate injury.

### WARNINGS

Warnings identify potentially dangerous situations or serious hazards. In this manual, a warning indicates an imminently hazardous situation which, if not avoided, could result in serious injury or death.

## Safety Messages

Follow all standard industry procedures for servicing electrical and computer equipment when working with or around high voltage. Always shut off the power supply before touching any components.

Electrical components are sensitive to electrostatic discharge. To prevent equipment damage, observe safety procedures when working with electrostatic sensitive components.

**WARNING!** Explosion hazard. Do not connect or disconnect equipment unless power has been switched off or the area is known to be non-hazardous.

## Low Voltage Directive

For use in Category II installations. If equipment is used in a manner not specified by manufacturer, protection provided by equipment may be impaired.

## Notice of Trademark, Copyright and Limitations

Magnetrol & Magnetrol logotype and STI & STI logotype, and Modulelevel are registered trademarks of Magnetrol International, Incorporated. Digital ES II, Digital ES II Modulelevel, Analog EZ & Analog EZ Modulelevel, Smart EZ & Smart EZ Modulelevel are tradenames of Magnetrol International, Incorporated.

Copyright © 2007 Magnetrol International, Incorporated. All rights reserved.

Performance specifications are effective with date of issue and are subject to change without notice. Magnetrol/STI reserves the right to make changes to the product described in this manual at any time without notice. Magnetrol/STI makes no warranty with respect to the accuracy of the information in this manual.

## Warranty

All Magnetrol/STI electronic level and flow controls are warranted free of defects in materials or workmanship for one full year from the date of original factory shipment.

If returned within the warranty period; and, upon factory inspection of the control, the cause of the claim is determined to be covered under the warranty; then, Magnetrol/STI will repair or replace the control at no cost to the purchaser (or owner) other than transportation.

Magnetrol/STI shall not be liable for misapplication, labor claims, direct or consequential damage or expense arising from the installation or use of equipment. There are no other warranties expressed or implied, except special written warranties covering some Magnetrol products.

## Quality assurance

The quality assurance system in place at Magnetrol/STI guarantees the highest level of quality throughout the company. Magnetrol/STI is committed to providing full customer satisfaction both in quality products and quality service.

Magnetrol's quality assurance system is registered to ISO 9001 affirming its commitment to known international quality standards providing the strongest assurance of product/service quality available.





# Electronic Modulelevel (Top Hat Assembly Design) Displacer Level Transmitter Installation, Operation and Maintenance Manual

## Table of Contents

<b>1.0 Complete Installation</b>	
1.1 Unpacking.....	1
1.2 Electrostatic Discharge (ESD) .....	1
1.3 Before you begin.....	2
1.3.1 Site Preparation .....	2
1.3.2 Equipment and Tools.....	2
1.3.3 Operational Considerations .....	3
1.4 Mounting .....	3
1.4.1 Installing a Tank Top Mounted Modulelevel.....	3
1.4.2 Installing a Chamber Type modulelevel.....	4
<b>2.0 Analog EZ Modulelevel Wiring and Calibration</b>	
2.1 Integral Transmitter Wiring .....	6
2.2 Remote Transmitter Wiring.....	7
2.3 Hazardous Location Wiring .....	7
2.4 Calibrating the Analog EZ Modulelevel.....	10
2.4.1 Direct Acting Field Calibration.....	10
2.4.2 Reverse Acting Field Calibration.....	11
2.4.3 Bench Calibration.....	11
<b>3.0 Digital ES II Modulelevel Wiring and Calibration</b>	
3.1 Integral Transmitter Wiring.....	14
3.2 Remote Transmitter Wiring.....	15
3.3 Hazardous Location Wiring .....	16
3.4 Digital ES II Push-button Calibration.....	16
3.4.1 Push-button Field Calibration .....	16
3.4.2 Push-button Bench Calibration .....	17
3.4.3 Digital Meter Calibration .....	18
3.4.4 Interface Calibration.....	19
3.4.4.1 Calibration in Process Liquids .....	20
3.4.4.2 Calibration in water only for interface of another liquid over water.....	20
3.4.4.3 Calibration in water only for interface of two other liquids.....	20
3.4.4.3.1 Lower S.G. less than or equal to 1.0 .....	20
3.4.4.3.2 Lower S.G. greater than 1.0.....	21
3.5 Configuration Using HART.....	22
3.5.1 Connections .....	22
3.5.2 Display Menu.....	22
3.5.3 Basic Field Calibration Using Hart HHC .....	22
3.5.4 Hart Menu .....	23
<b>4.0 Reference Information</b>	
4.1 Description.....	25
4.2 Theory of Operation .....	26
4.2.1 Displacer Buoyancy .....	26
4.2.2 LVDT.....	26
4.3 Troubleshooting.....	26
4.4 Maintenance of Analog EZ Modulelevel.....	28
4.4.1 Replacing Transmitter PC Board .....	28
4.4.2 Replacing Power Supply PC Board .....	28
4.4.3 Replacing LVDT .....	29
4.4.4 Checking the LVDT Winding Resistance .....	29
4.5 Maintenance of Digital ES II Modulelevel.....	29
4.5.1 Replacing Transmitter PC Board .....	29
4.5.2 Replacing LVDT .....	30
4.5.3 Checking the LVDT Winding Resistance .....	30
4.6 Agency Approvals .....	31
4.6.1 FM (Factory Mutual).....	31
4.6.2 CSA (Canadian Standards Association).....	31
4.6.3 CENELEC (Comité Européen de Normalisation Electrotechnique).....	32
4.7 Parts .....	33
4.7.1 Replacement PC Boards .....	33
4.7.2 Transmitter Head Parts.....	34
4.7.3 Recommended Spare Parts.....	34
4.7.4 Mechanical Replacement Parts.....	35
4.7.5 Upgrade to ESII Electronics .....	37
4.7.5.1 ES to ES II Conversion .....	37
4.7.5.2 EZ to ES II Conversion.....	38
4.8 Specifications.....	39
4.8.1 Functional .....	39
4.8.2 Performance.....	40
4.8.3 Physical.....	41
4.9 Model Numbers .....	43
4.9.1 Models for Steam Applications (max. 600 lbs.).....	43
4.9.2 Models for Steam Applications (900-2500 lbs.).....	45
4.9.3 Models for Non-Steam Applications (max. 600 lbs.).....	47
<b>Glossary</b> .....	49

---

## 1.0 Mechanical Installation

This section provides detailed procedures for properly installing the Electronic Modulelevel Displacer Level Transmitter.

### 1.1 Unpacking

Unpack the instrument carefully. Take care not to bend the displacer stem or enclosing tube. Ensure all components have been removed from the packing material. Check all the contents against the packing slip and report any discrepancies to the factory.

Before proceeding with the installation, do the following:

- Inspect all components for damage. Report any damage to the carrier within 24 hours.
- On chambered units, remove the shipping strap and wire assembly holding the displacer in place. This assembly must be removed through the bottom chamber connection before start-up.

**Caution:** If reshipping to another location, the displacer must again be secured using the same strap and wire assembly.

- Check that the model number on the nameplate matches the packing slip and purchase order.
- Record the model and serial numbers for future reference when ordering parts.

Model Number \_\_\_\_\_

Serial Number \_\_\_\_\_

### 1.2 Electrostatic Discharge (ESD) Handling Procedure

Magnetrol's electronic instruments are manufactured to the highest quality standards. These instruments use electronic components which may be damaged by static electricity present in most work environments.

The following steps are recommended to reduce the risk of component failure due to electrostatic discharge.

- Ship and store circuit boards in anti-static bags. If an anti-static bag is not available, wrap the board in aluminum foil. Do not place boards on foam packing materials.
- Use a grounding wrist strap when installing and removing circuit boards. A grounded workstation is recommended.

- 
- Handle circuit boards only by the edges. Do not touch components or connector pins.
  - Ensure that all electrical connections are completely made and that none are partial or floating. Ground all equipment to a good, earth ground.

## **1.3 Before You Begin**

### **1.3.1 Site Preparation**

Each Modulelevel transmitter is built to match the specific physical specifications of the required installation. Ensure that the process connection(s) on the vessel matches the Modulelevel's process connection(s).

See *Mounting, Section 1.4*.

Ensure that the wiring between the power supply and Modulelevel transmitter are complete and correct for the type of installation.

See *Specifications, Section 4.8*.

When installing the Modulelevel transmitter in a general purpose or hazardous area, local, state and federal regulations and guidelines must be observed.

See *Wiring, Sections 2.0 & 3.0*.

### **1.3.2 Equipment and Tools**

No special equipment or tools are required to install the Electronic Modulelevel. The following items are recommended:

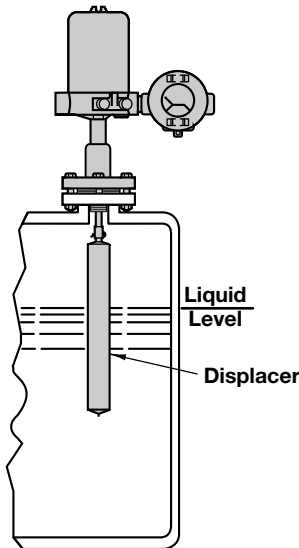
- Wrenches, flange gaskets and flange bolting appropriate for process connection(s)
- Flat-blade screwdriver
- Level
- 1/8" Allen wrench
- Power supply which matches voltage identification on nameplate
- Multimeter with maximum sensitivity of 100 millivolts for 120 or 240 VAC transmitters
- 250 to 450 ohm resistor for transmitters with HART communication

### 1.3.3 Operational Considerations

The Modulevel transmitter should be located for easy access for service, configuration, and monitoring. There should be sufficient headroom to allow installation and removal of the transmitter head and, in cases of tank top configuration, the displacer. Special precautions should be made to prevent exposure to corrosive atmosphere, excessive vibration, shock, or physical damage.

The operating temperature range for the transmitter electronics is  $-40^{\circ}$  to  $+160^{\circ}$  F ( $-40^{\circ}$  to  $+70^{\circ}$  C). The operating temperature range for the digital display is  $-4^{\circ}$  to  $+160^{\circ}$  F ( $-20^{\circ}$  to  $+70^{\circ}$  C).

Operation of all buoyancy type level devices should be done in such a way as to minimize the action of dynamic forces on the float or displacer sensing element. Good practice for reducing the likelihood of damage to the control is to equalize pressure across the device very slowly.



**Figure 1**  
**Tank Top Mounted**  
**Installation**

### 1.4 Mounting

The Modulevel transmitter can be mounted to a tank using a variety of configurations and process connections. Generally, either a threaded, welded or flanged connection is used with an external cage. A flanged connection is always used on a tank top model. For information about the sizes and types of connections available, see *Model Numbers, Section 4.9*.

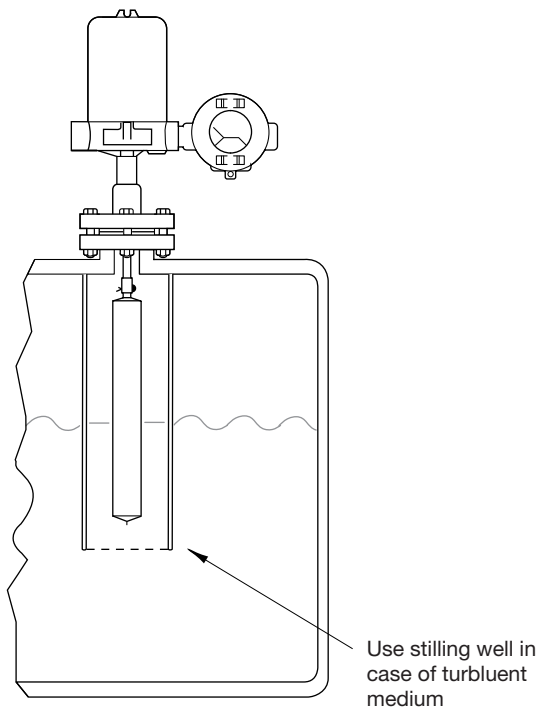
Ensure all mounting connections are in place on the tank and properly sized for the specific unit being installed. Compare the model on the nameplate with the product information to ensure the Modulevel transmitter is correct for the intended installation.

#### 1.4.1 Installing a Tank Top Mounted Modulevel (E61, E62, E51 and E52 models)

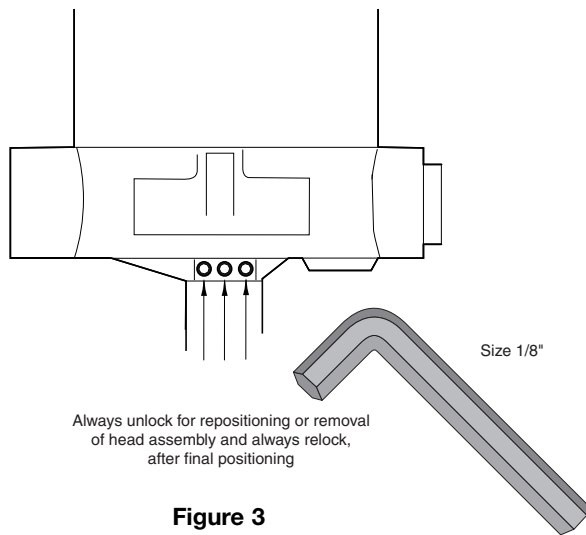
Figure 1 illustrates a typical tank top installation.

Before installing, ensure that:

- There is adequate headroom for the installation of the Modulevel head and displacer and that it has unobstructed entry into the vessel.
- Using a level, the mounting flange is horizontal within  $3^{\circ}$ .
- If the adjustable hanger assembly (P/N 32-3110-001) is used, it is cut to the required length and attached to the displacer stem.



**Figure 2**  
**Tank Top Mounted**  
**with Stilling Well**



**Figure 3**  
**Transmitter Head**  
**Lock Screws**

Note: The adjustable hanger assembly is used when the top of the displacer and, therefore, the top of the measurement range must be positioned in the vessel more than 5" (127 mm) below the mounting flange in the case of models 600# or less, or more than 9.31" below the mounting flange on models 900# or greater. The maximum hanger cable length is 8 feet.

- A stilling well is installed for applications where continuous agitation is present. The stilling well must be vertically level so as not to restrict displacer movement. See Figure 2 for a typical stilling well installation.
- The process temperature, pressure and specific gravity are within the unit's specifications for installation. See *Specifications, Section 4.8*.

To install:

1. Carefully place the displacer in the vessel. Align the gasket on the flange.
2. Align the Modulelevel flange with the flanged connection on the vessel.
3. Make sure the flange gasket is seated properly. Install flange bolts and nuts.
4. Tighten alternating flange bolts in a star pattern.

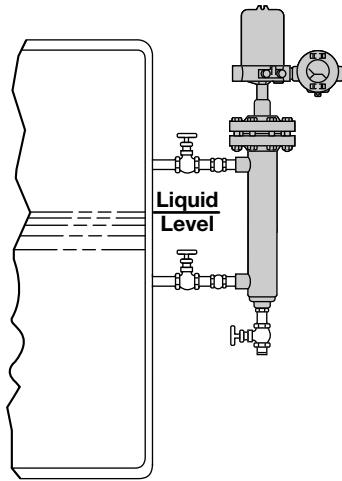
**Caution:** All Modulelevels are shipped from the factory with the enclosing tube tightened and the transmitter head set screws locked to the enclosing tube. Failure to loosen the set screws prior to repositioning the supply and output connections may cause the enclosing tube to loosen, resulting in the possible leakage of the process liquid or vapor.

5. Loosen the transmitter head lock screws (socket type) and position conduit outlet in the desired direction. See Figure 3.
6. Retighten lock screws.

Note: Since the transmitter head is rotatable through 360°, it is important to make certain that the controller locking screws are tight before making electrical connections.

#### 1.4.2 Installing a Chamber Type Modulelevel (E63, E64, E65, E66, E53, and E55)

The chamber type Modulelevel is mounted on the side of the vessel with either a side/side or side/bottom connection, as furnished. Figure 4 on page 5 illustrates a typical chamber type installation.



**Figure 4**  
**Chamber Type Installation**  
**Side-Side Process Connections**

Before installing, ensure that:

- There is adequate room for the installation of the Modulelevel.
- Using a level, the vessel mounting connections are level within  $3^\circ$  of vertical.
- The process temperature, pressure and specific gravity are within the unit's specifications for installation. See *Specifications, Section 4.8*.
- If not already done, remove the shipping strap and wire assembly holding the displacer in place in the chamber. This assembly must be removed through the bottom chamber connection or drain before start-up.

To install:

1. Carefully align the Modulelevel chamber process connections with the vessel connections.
2. Attach the process connections accordingly, based on the type of connection. Appropriate gaskets and bolting will be required if using flanged process connections.

**Note:** It is recommended that shut-off valves be installed in each equalizing line to the chamber, along with a blow-down valve (refer to Figure 4). Equalizing lines should be sized at least as large as the connections provided at the chamber.

3. Make sure that the chamber is vertically level within  $3^\circ$  in each direction to ensure frictionless operation of the internal displacer.

**Caution:** All Modulelevels are shipped from the factory with the enclosing tube tightened and the transmitter head set screws locked to the enclosing tube. Failure to loosen the set screws prior to repositioning the supply and output connections may cause the enclosing tube to loosen, resulting in the possible leakage of the process liquid or vapor.

4. Loosen the transmitter head lock screws (socket type) and position conduit outlet in the desired direction. See Figure 3 on page 4.
5. Retighten lock screws.

**Note:** Since the transmitter head is rotatable through  $360^\circ$ , it is important to make certain that the controller locking screws are tight before making electrical connections.

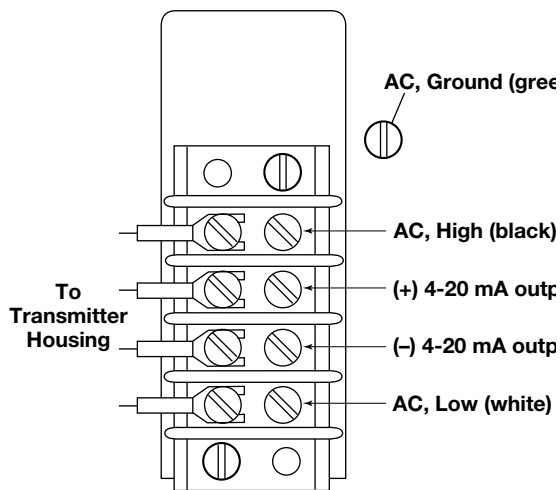
## 2.0 Analog EZ Modulelevel Wiring and Calibration

**Caution:** The Analog EZ Modulelevel Transmitter operates at voltages 12–36 VDC, 120 VAC or 240 VAC. Incorrect voltages will damage the transmitter.

All wiring between the power supply and the Modulelevel transmitter on 24 VDC units should be made using 18-22 AWG shielded twisted pair instrument cable or on 120 VDC and 240 VAC units should be made using a quantity of 14-16 AWG conductors and ground. All wiring connections to the transmitter are made in the attached junction box.

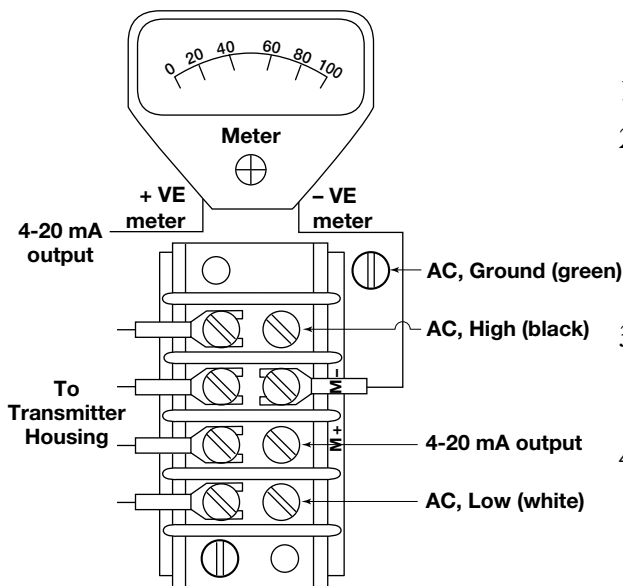
NO WIRING CONNECTIONS ARE REQUIRED INSIDE THE TRANSMITTER HOUSING ON INTEGRAL UNITS. Instructions for wiring the Modulelevel transmitter depend on type of mounting, integral or remote, and the area classification required, intrinsically safe, explosion proof or non-incendive.

**WARNING!** Turn off all power before making any electrical connection.



Series EZB, EZC, GZR, GZS,  
GZ2 and GZ3 Blind Transmitters  
120 and 240 VAC Supply Conduit Junction Box

Figure 5



Series EZL, EZN, GZU, GZV,  
GZ5 and GZ6 Transmitters with Meter  
120 and 240 VAC Supply Conduit Junction Box

Figure 6

### 2.1 Integral Transmitter Wiring

Note: Before connecting the power supply to the transmitter, be sure that the voltage identification on the nameplate matches the power supply. Do NOT attempt to operate this unit at voltages other than as identified as it will damage the unit.

1. Remove the cover to the junction box of the transmitter.
2. If unit is supplied with meter, access terminal board by removing the two screws securing the meter/bracket assembly to the junction box housing and moving meter/bracket assembly out of the way. Do not disconnect wires. If unit has no meter, terminal board is already accessible.
3. Install an approved conduit seal within 18" of the junction box for explosion proof installation. For IS installation, see page 9.
4. Pull the supply wires and connect to the terminals as indicated in the wiring diagram for the unit having the appropriate voltage and meter configuration, see Figures 5, 6, 7 & 8 on pages 6-7.
5. Replace meter/bracket assembly, if supplied, by positioning the holes in the bracket assembly over those in the junction box housing and replacing the two screws.
6. Replace the junction box cover. Ensure that the cover is tightened down sufficiently to compress o-ring seal.

Note: When operated from a 24 VDC source, the maximum allowable loop resistance is 480 ohms for Analog EZ Modulelevels. See Figure 9.

When operated from a 120 or 240 VAC source, the Analog EZ current can only be monitored from the meter terminals (M+ and M-) using a multimeter with maximum sensitivity of 100 millivolts.

**Caution:** Instrument and conduit junction box covers must be in place and tightly sealed at all times during operation.

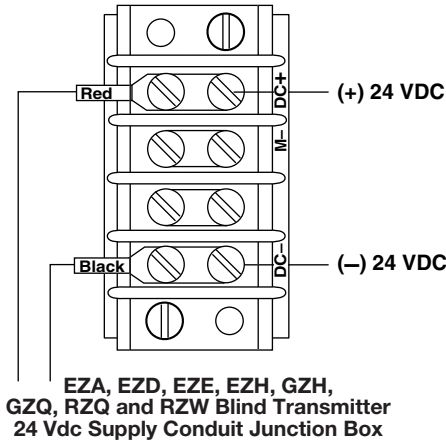


Figure 7

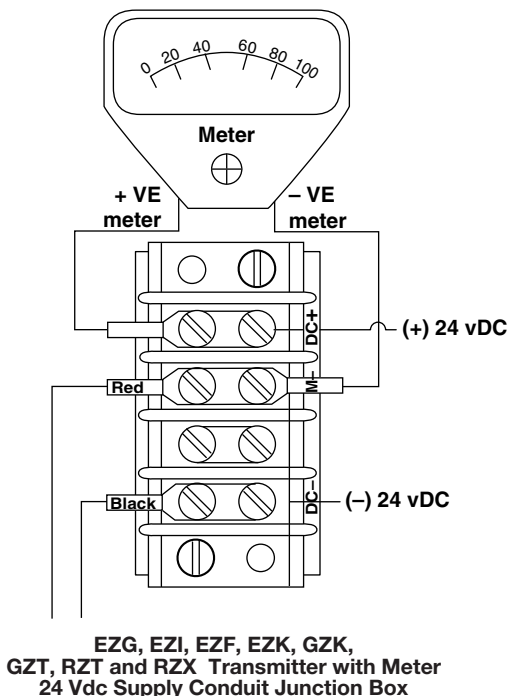


Figure 8

## 2.2 Remote Transmitter Wiring

Note: Before connecting the power supply to the transmitter, be sure that the voltage identification on the nameplate matches the power supply. Do NOT attempt to operate this unit at voltages other than as identified as it will damage the unit.

1. Remove the cover of the remote transmitter and of the LVDT housing.
2. Connect one end of the six conductor cable (P/N 037-3218-xxx or 037-3220-xxx) to the LVDT terminal block and the other end to the terminal block within the remote transmitter housing. Be sure to match the six discrete numbered wires with the numbers on each terminal block. See Figure 10.
3. Wire the power supply to the terminal board in the junction box and seal the conduit per the instructions in Section 2.1.

Note: When operated from a 24 VDC source, the maximum allowable loop resistance is 480 ohms for Analog EZ Modulelevels. See Figure 9.

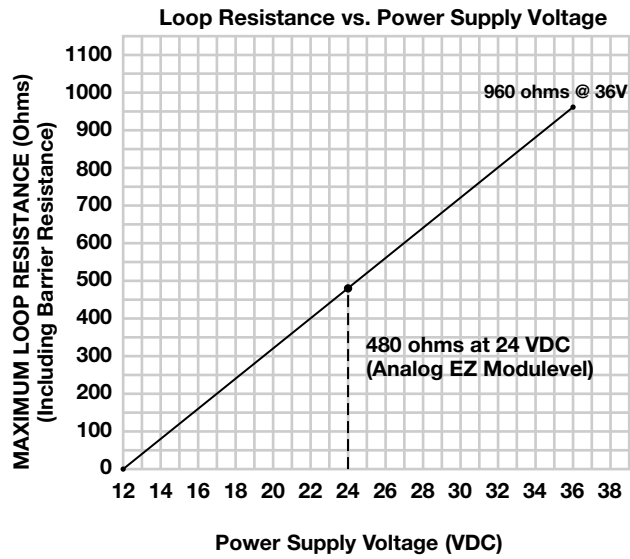
When operated from a 120 or 240 VAC source, the Analog EZ current can only be monitored from the meter terminals (M+ and M-) using a multimeter with maximum sensitivity of 100 millivolts.

**Caution:** Instrument and conduit junction box covers must be in place and tightly sealed at all times during operation.

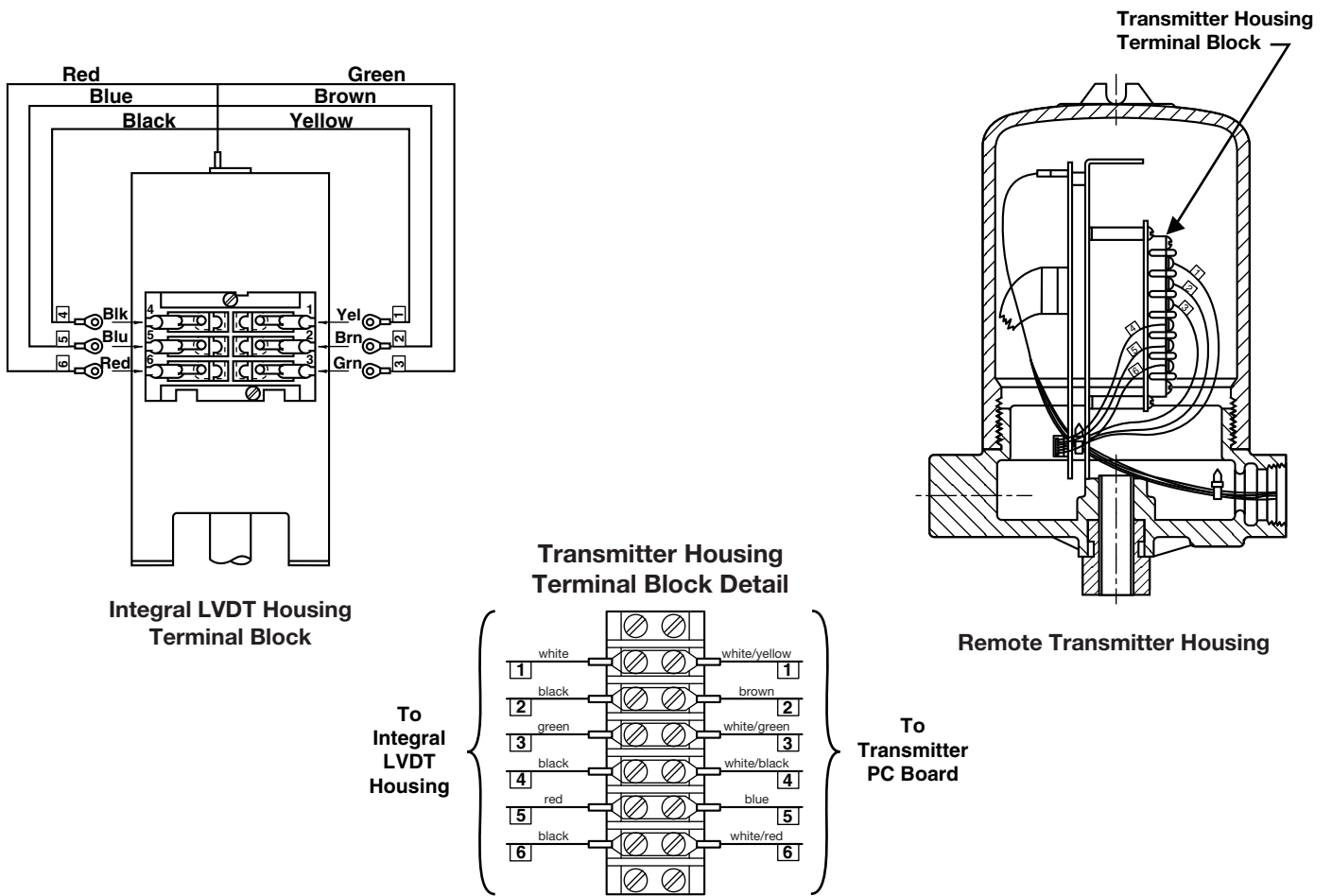
## 2.3 Hazardous Location Wiring

Figure 11 illustrates the proper installation for Intrinsically Safe wiring. Figure 12 illustrates Intrinsically Safe Connections/Non-incendive wiring. See page 9.

NOTE: Intrinsically Safe Connections require that the remote mount electronics and LVDT housings must be installed explosion proof.



**Figure 9**  
**Analog EZ**  
**Maximum Loop Resistance**



**Figure 10**  
**Analog EZ**  
**Remote Mounted Transmitter Wiring**

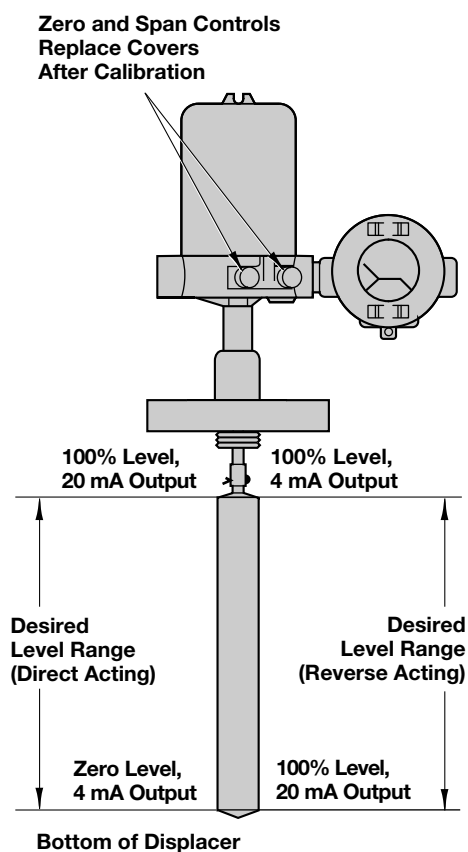


## 2.4 Calibrating the Analog EZ Modulelevel

The Analog EZ Modulelevel must be calibrated for each unique application. It may be calibrated in service or on a bench calibration stand. Bench calibration provides a convenient way to set up the transmitter before going to the tank site to complete the installation. Bench calibration, however, does not compensate for elevated process temperatures.

For convenience during the calibration of a blind transmitter, a DC milliammeter may be connected to terminals (M+) and (M-) in the junction box, see Figure 5 on page 6.

### 2.4.1 Direct Acting Field Calibration



**Figure 13**  
Analog EZ Modulelevel  
Field Calibration

1. Bring process up to operating temperature.
  2. Unscrew and remove protective covers from zero and span controls. See Figure 13.
  3. Rotate the span control counterclockwise fully, approximately 20 turns.
  4. Rotate the zero control counterclockwise fully, approximately 20 turns.
  5. Establish liquid level at the desired 4 mA (0%) level on the displacer.
  6. Adjust the zero control until the output signal is 4.00 mA (0% on transmitter with analog meter).
  7. Replace cover on zero control.
  8. Establish liquid level at the desired 20 mA (100%) level on the displacer.
  9. Adjust the span control until the output signal is 20.00 mA (100% on transmitter with analog meter).
- In the case that 20 mA (100%) level cannot be established:
10. After setting the zero point, establish liquid level as close to the 20 mA level as possible.
  11. Adjust the span control until the output signal corresponds with the % of actual level (e.g. 80 % level should equal  $(20 \text{ mA} - 4 \text{ mA}) \times 80\% + 4 \text{ mA} = 16.8 \text{ mA}$ ).
  12. Replace cover on span control.

## 2.4.2 Reverse Acting Field Calibration

Analog EZ Module levels are factory set for direct action (rising level increases output signal). The following adjustment is required for reverse action.

1. Remove power from unit.
2. Remove transmitter housing cover.
3. Locate the Direct/Reverse switch on the PC board. See Figure 14.
4. Move the Direct/Reverse switch to “REV.”
5. Replace and tighten the transmitter housing cover until the o-ring is compressed.
6. Bring process up to operating temperature.
7. Unscrew and remove protective covers from zero and span controls. See Figure 13 on page 10.
8. Rotate the span control counterclockwise fully, approximately 20 turns.
9. Rotate the zero control counterclockwise fully, approximately 20 turns.
10. Establish liquid level at the desired 4 mA (100%) level on the displacer.
11. Adjust the zero control until the output signal is 4.00 mA (0% on transmitter with analog meter).
12. Replace cover on zero control.
13. Establish liquid level at the desired 20 mA (0%) level on the displacer.
14. Adjust the span control until the output signal is 20.00 mA (100% on transmitter with analog meter).



**Figure 14**  
**Analog EZ Transmitter**  
**PC Board**

## 2.4.3 Bench Calibration

The Analog EZ Module level can be bench calibrated using the calibration stand (P/N 31-6107-001) (except units that have been calibrated for interface service. Bench calibration cannot be performed on interface models). The fixture includes an open-topped enclosing tube upon which the transmitter head is mounted and an adjustment rod which simulates level movement of liquids with various S.G.s.

To remove transmitter head from control:

1. Disconnect field wiring at the junction box.
2. Loosen the housing base lock screws. See Figure 3 on page 4.
3. Remove transmitter housing cover.
4. Remove c-ring from enclosing tube using snap ring pliers.
5. Slide transmitter on housing base upward until clear of the enclosing tube.

---

To install transmitter head on calibration stand, carefully slide the white teflon spacer and LVDT assembly down over the open topped enclosing tube. Be certain that both the LVDT assembly and the housing base are fully seated on the fixture. See Figure 15 on page 13.

To bench calibrate the Analog EZ transmitter:

1. Connect appropriate supply voltage and meter, if necessary, to terminals in junction box. See Figure 5, 6, 7 & 8 on pages 6-7.
2. Unscrew and remove protective covers from zero and span controls. See Figure 13 on page 10.
3. Rotate the span control counterclockwise fully, approximately 20 turns.
4. Rotate the zero control counterclockwise fully, approximately 20 turns.
5. Push the adjustment rod completely down into the enclosing tube to simulate low level. See Figure 15 on page 13.
6. Adjust the zero control until the output signal is 4.00 mA (0% on transmitter with analog meter).
7. Replace cover on zero control.
8. Lift the adjustment rod until the top of the enclosing tube is aligned with the marking on the rod that corresponds to the S.G. of your process liquid.
9. Adjust the span control until the output signal is 20.00 mA (100% on transmitter with analog meter).
10. Replace cover on span control.
11. Disconnect power and meter (if used) and remount transmitter head onto control by reversing the removal procedure.

Note: Bench calibration does not compensate for elevated process temperatures.

Note: To bench calibrate for reverse action, after moving the Direct/Reverse Switch to "Rev" position, adjust the zero control with the adjustment rod positioned at the S.G. marking on the rod. Adjust the span control with the adjustment rod down until firmly seated on calibration tube (see "Bench Calibration" procedure above).

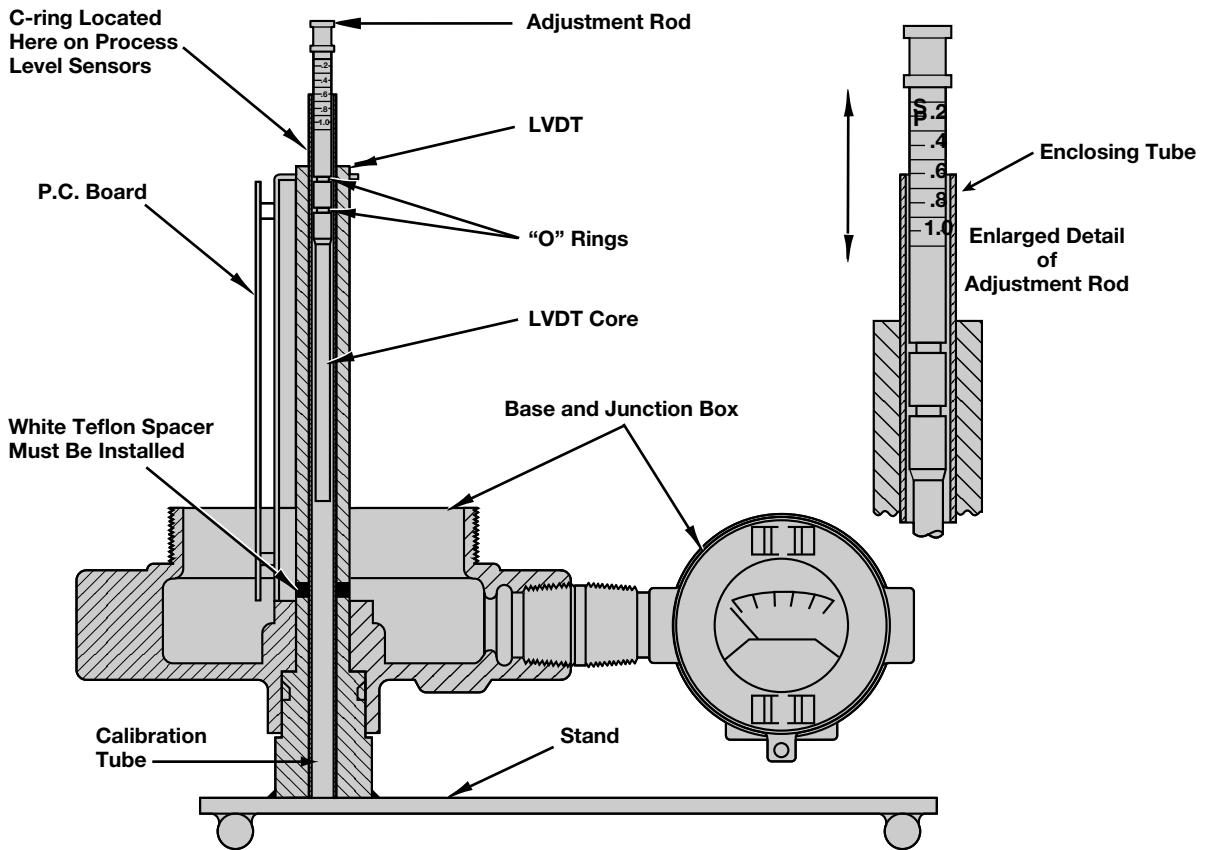


Figure 15  
Bench Calibration Stand  
(part number 31-6107-001)

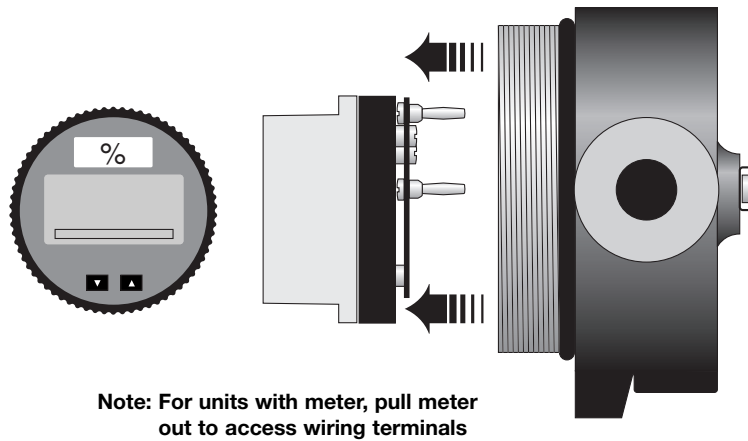


Figure 16  
Digital Meter Removal

### 3.0 Digital ES II Modulelevel Wiring and Calibration.

**Caution:** The Digital ES II Modulelevel Transmitter operates at voltages of 12-36 VDC. Incorrect voltages will damage the transmitter.

All wiring between the power supply and the Modulelevel transmitter should be made using 18-22 AWG shielded twisted pair instrument cable. All wiring connections to the transmitter are made in the attached junction box. NO WIRING CONNECTIONS ARE REQUIRED INSIDE THE TRANSMITTER HOUSING ON INTEGRAL UNITS. Instructions for wiring the Modulelevel transmitter depend on type of mounting, integral or remote, and the area classification required, intrinsically safe, explosion proof or non-incendive.

**WARNING!** Turn off all power before making any electrical connection.

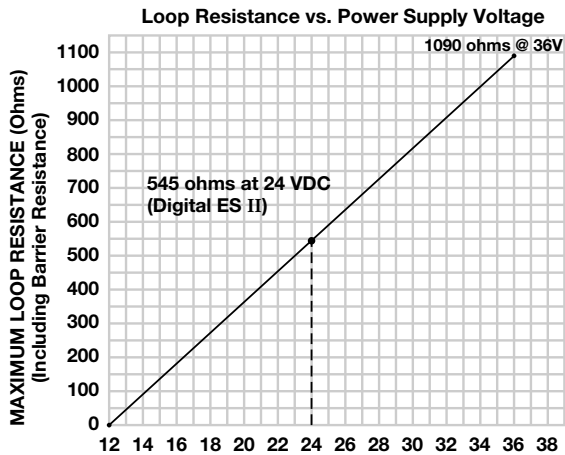


Figure 17  
Digital ES II  
Maximum Loop Resistance

#### 3.1 Integral Transmitter Wiring

Note: Before connecting the power supply to the transmitter, be sure that the voltage identification on the name-plate matches the power supply. Do NOT attempt to operate this unit at voltages other than as identified as it will damage the unit.

1. Remove the cover to the junction box of the transmitter.
2. If unit is supplied with meter, access terminal board by pulling meter straight out until it unplugs. See Figure 16. If unit has no meter, terminal board is already accessible.
3. Install an approved seal within 18" of the junction box conduit.
4. Pull the supply wires and connect to the terminals as indicated in the wiring. See Figure 18.
5. Replace meter, if supplied, by pushing banana plugs firmly into receptacles.
6. Replace junction box cover. Ensure that the cover is tightened down sufficiently to compress o-ring seal.

Note: When operated from a 24 VDC source, the maximum allowable loop resistance is 545 ohms for Digital ES II Modulelevels. See Figure 17.

When using HART, a loop resistance of 250 to 450 ohms must be placed in series with the Digital ES II Modulelevel.

**Caution:** Instrument and conduit junction box covers must be in place and tightly sealed at all times during operation.

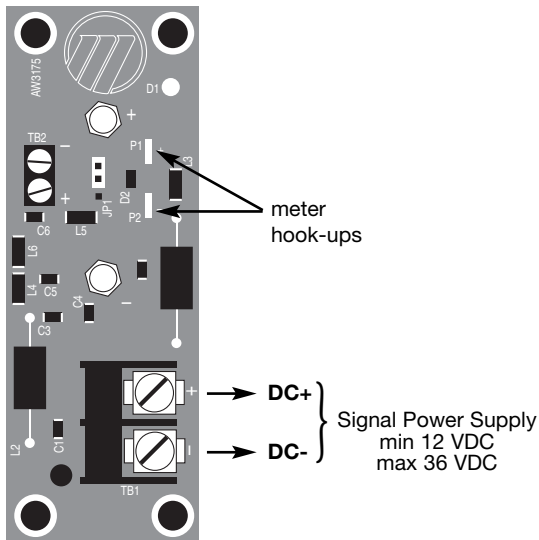


Figure 18  
Digital ES II Terminal Board

### 3.2 Remote Transmitter Wiring

Note: Before connecting the power supply to the transmitter, be sure that the voltage identification on the nameplate matches the power supply. Do NOT attempt to operate this unit at voltages other than as identified as it will damage the unit.

1. Remove the cover of the remote transmitter and of the LVDT housing.
2. Connect one end of the six conductor cable (P/N 037-3218-xxx or 037-3220-xxx) to the LVDT terminal block and the other end to the terminal block within the remote transmitter housing. Be sure to match the six discrete numbered wires with the numbers on each terminal block. See Figure 19.
3. Wire the power supply to the terminal board in the junction box and seal the conduit per the instructions in Section 3.1.

Note: When operated from a 24 VDC source, the maximum allowable loop resistance is 545 ohms for Digital ES II Modulevels. When using HART, a loop resistance of 250 to 450 ohms must be placed in series with the Digital ES II Modulevel. See Figure 17 on page 14.

**Caution:** Instrument and conduit junction box covers must be in place and tightly sealed at all times during operation.

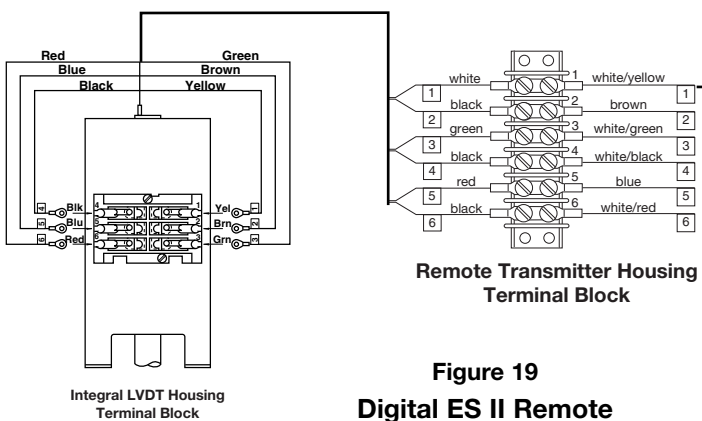
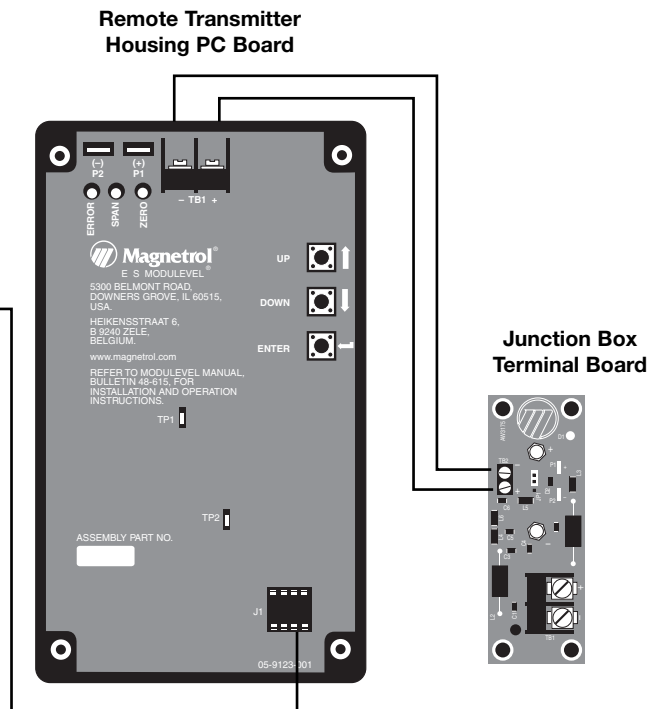


Figure 19  
Digital ES II Remote Mounted Transmitter Wiring



### 3.3 Hazardous Location Wiring

See Figure 11 on page 9 for proper installation of Digital ES II for intrinsically safe locations. Proper installation of Digital ES II with intrinsically safe connections and non-incendive wiring is illustrated in Figure 12 on page 9.

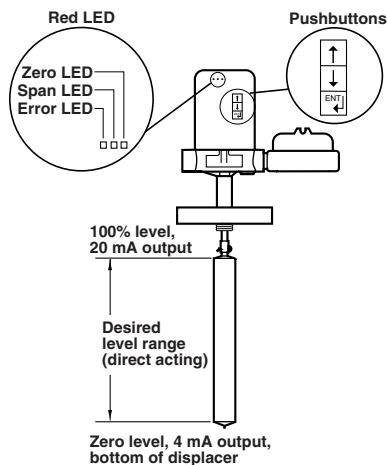
### 3.4 Digital ES II Push-Button Calibration

The Digital ES II Modulelevel must be calibrated for each unique application. It may be calibrated using the push-buttons on the PC board or using a HART communicator. The HART hand-held communicator allows advanced calibration.

The Digital ES II Modulelevel may be calibrated in service or on a bench calibration stand (P/N 31-6107-001) (except units that have been calibrated for interface service. Bench calibration cannot be performed on interface models). Bench calibration provides a convenient way to set up the transmitter before going to the tank site to complete the installation. Bench calibration, however, does not compensate for elevated process temperatures and must be fine tuned in the field.

#### 3.4.1 Push-button field calibration

1. Bring process up to operating temperature.
2. Establish liquid level at desired 4 mA (0%) level on displacer. If 4 mA level is at the bottom of the displacer, 4 mA point may be set with displacer hanging free in vapor.
3. With unit power on, remove cover.
4. Press the ENTER key to start calibration. The ZERO LED will light. Loop will go to 22 mA. See Figure 20 on page 16.
5. Press the DOWN key to lock in the 4 mA value. The ZERO LED will flash and remain on. Loop will stay at 22 mA.
6. Press ENTER to confirm the setting. The ZERO LED will go off. Loop will go to 4 mA.
7. Establish liquid at the 20 mA (100%) level on the displacer.
8. Press ENTER to start calibration. The ZERO LED will light. Loop will go to 22 mA.
9. Press UP to lock in the 20 mA value. The ZERO LED will go off. The SPAN LED will be on. Loop will go to 20 mA.
10. Press ENTER to confirm the setting. The SPAN LED will go off. Loop will stay at 20 mA.



**Figure 20**  
**Digital ES II Push-button Calibration**

---

In the case that 20 mA (100%) level cannot be established:

11. After setting the zero point, establish the liquid level as close to the 20 mA level as possible (must be more than 50% of the total span).
12. Press ENTER to start 20 mA calibration. The ZERO LED will light. Loop will go to 22 mA.
13. Press UP to lock in 20mA value. The ZERO LED will go off. The SPAN LED will be on. Loop will go to 20 mA.
14. Toggle UP and DOWN until the loop signal corresponds with the % of actual level (e.g. 80 % level should equal  $(20 \text{ mA} - 4 \text{ mA}) \times 80\% + 4 \text{ mA} = 16.8 \text{ mA}$ ).
15. Press ENTER to confirm the setting. The SPAN LED will go off. Loop will stay at value chosen in step 14 above.
16. Replace cover.

Note: When calibrating for reverse action (4 mA at high level, 20 mA at low level) step 2 will be establishing high level at the 4 mA level and step 7 will be bringing the level down to the 20 mA level.

### 3.4.2 Push-button Bench Calibration

---

The Digital ES II Module level can be bench calibrated using the calibration stand (P/N 31-6107-001) (except units that have been calibrated for interface service. Bench calibration cannot be performed on interface models). The fixture includes an open topped enclosing tube upon which the transmitter head is mounted and an adjustment rod which simulates level movement of liquids with various S.G.s. Bench calibration does not compensate for elevated process temperatures and must be fine tuned in the field.

To remove transmitter head from control:

1. Disconnect field wiring at the junction box.
2. Loosen the housing base lock screws. See Figure 3 on page 4.
3. Remove transmitter housing cover.
4. Remove c-ring from enclosing tube using snap ring pliers.
5. Slide transmitter on housing base upward until clear of the enclosing tube.

To install transmitter head on calibration stand, carefully slide the white teflon spacer and LVDT assembly down over the open topped enclosing tube. Be certain that both the LVDT assembly and the housing base are fully seated on the fixture. See Figure 15 on page 13.

---

To bench calibrate the Digital ES II transmitter:

1. Connect supply voltage and meter, if necessary, to terminals in junction box. See Figure 18 on page 14.
2. Slide the electronics head over the open topped enclosing tube of the calibration stand, making sure that the white plastic washer is in place below the electronics head. See Figure 15 on page 13.
3. Push the adjustment rod completely down into the enclosing tube to simulate low level.
4. Press the ENTER key to start calibration. The ZERO LED will light. Loop will go to 22 mA.
5. Press the DOWN key to lock in the 4 mA value. The ZERO LED will flash and remain on. Loop will stay at 22 mA.
6. Press ENTER to confirm the setting. The ZERO LED will go off. Loop will go to 4 mA.
7. Lift the adjustment rod until the top of the enclosing tube is aligned with the marking on the rod that corresponds to the S.G. of your process liquid.
8. Press ENTER to start calibration. The ZERO LED will light. Loop will go to 22 mA.
9. Press UP to lock in the 20 mA value. The ZERO LED will go off. The SPAN LED will be on. Loop will go to 20 mA.
10. Press ENTER to confirm the setting. The SPAN LED will go off. Loop will stay at 20 mA.

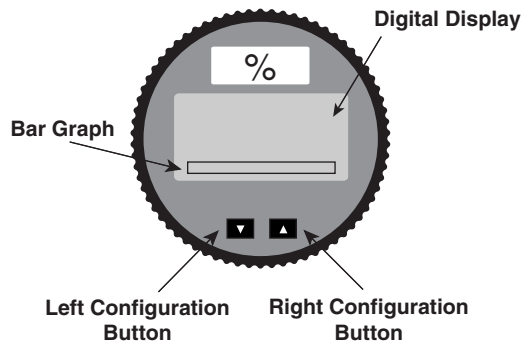
Note: To calibrate for reverse action, follow the same procedures as above, but calibrate 4 mA as 100% (adjustment rod at your S.G.) and 20 mA as 0% (adjustment rod all the way down).

### 3.4.3 Digital Meter Calibration

---

The digital meter on the Digital ES II Module level is set at the factory to display 00.0% when the loop current is 4.0 mA and 100.0% when the loop current is 20.0 mA. The following instructions may be followed if a different configuration is required. Regardless of the configuration of the numeric display, the analog bar graph represents 4 – 20 mA directly. Meter configuration does not affect the loop current and is easily done with no additional equipment.

1. Remove transmitter junction box housing cover.
2. Unscrew and remove the transparent meter cover.



**Figure 21**  
**Digital Meter**

### 3.4.3 Digital Meter Calibration (cont.)

To position the decimal point and choose meter function:

3. Simultaneously press and immediately release the left and right configuration buttons. See Figure 21.
4. To move the decimal point, press the left button until decimal point is in desired location.
5. To choose meter function, press right button until desired function is displayed. L in=linear, L inF=linear with five second filter, Srt = Square root and SrtF = Square root with five second filter.
6. Simultaneously press both configuration buttons for two seconds to store chosen configurations.

To set 4 mA reading:

7. Press left button for two seconds.
8. Using the left button to decrease the reading and the right to increase the reading, set display to the desired 4 mA reading.
9. Simultaneously press both buttons to store the 4 mA reading.

To set 20 mA reading:

10. Press right button for two seconds.
11. As in step 8 above, set display to desired 20 mA reading.
12. Simultaneously press both buttons to store the 20 mA reading.
13. Replace transparent meter cover and transmitter junction box cover.

### 3.4.4 Interface Calibration

#### 3.4.4.1 Calibration in Process Liquids

**IMPORTANT:** Displacer must always be completely submerged in one or both process liquids.

1. Bring process up to operating temperature.
2. Establish interface level at desired 4 mA (10%) level on the displacer. If 4 mA level is at the bottom of the displacer, 4 mA point may be set with displacer immersed in upper liquid only.
3. With unit power on, remove cover.
4. Press the ENTER key to start calibration. The ZERO LED will light. Loop will go to 22 mA.
5. Press the DOWN key to lock in the 4 mA value. The ZERO LED will flash and remain on. Loop will stay at 22 mA.
6. Press ENTER to confirm the setting. The ZERO LED will go off, and the loop will go to 4 mA.

---

### 3.4.4 Interface Calibration (cont.)

7. Establish interface level at desired 20 mA (100%) level on the displacer.
8. Press the ENTER key. The ZERO LED will light. Loop will go to 20 mA.
9. Press UP to lock in the 20 mA value. The ZERO LED will go off. The SPAN LED will light. Loop will go to 20 mA.
10. Press ENTER to confirm setting. The SPAN LED will go off, and the loop will go to 20 mA.

#### 3.4.4.2 Calibration in water only for interface of another liquid over water.

The example calibration below assumes an upper specific gravity of 0.80. For liquid with another S.G., immerse displacer by the percentage equal to that S.G.

(EX: S.G. = 0.73, immerse displacer 73%)

1. Bring process up to operating temperature.
2. Establish water level at 80% level on displacer.
3. With unit power on, remove cover.
4. Press the ENTER key to start calibration. The ZERO LED will light. Loop will go to 22 mA.
5. Press the DOWN key to lock in the 4 mA value. The ZERO LED will flash and remain on. Loop will stay at 22 mA.
6. Press ENTER to confirm the setting. The ZERO LED will go off, and the loop will go to 4 mA.
7. Immerse displacer completely in water.
8. Press the ENTER key. The ZERO LED will light. Loop will go to 20 mA.
9. Press UP to lock in the 20 mA value. The ZERO LED will go off. The SPAN LED will light. Loop will go to 20 mA.
10. Press ENTER to confirm setting. The SPAN LED will go off, and the loop will go to 20 mA.

#### 3.4.4.3 Calibration in water only for interface of two other liquids.

##### 3.4.4.3.1 Lower S.G. less than or equal to 1.0.

When S.G. of lower liquid is less than or equal to 1.0, calibrate as follows (this example assumes upper S.G. = 0.78 and lower S.G. = 0.98):

1. Bring process up to operating temperature.
2. Establish water at the point on displacer equal to the upper S.G.  $\times$  100% (EX.  $0.78 \times 100\% = 78\%$ ).
3. Ensure there is no explosion hazard. With unit power on, remove cover.

- 
4. Press ENTER key to start calibration. ZERO LED will light. Loop will go to 22 mA.
  5. Press DOWN key to lock in 4 mA value. Zero LED will flash and remain on. Loop will stay at 22 mA.
  6. Press ENTER to confirm setting. ZERO LED will go off, and loop will go to 4 mA.
  7. Establish water at the point on displacer equal to the lower S.G.  $\times 100\%$  (EX.  $0.98 \times 100\% = 98\%$ ).
  8. Press ENTER key. ZERO LED will light. Loop will go to 20 mA.
  9. Press UP key to lock in 20 mA value. ZERO LED will go off. SPAN LED will light. Loop will go to 20 mA.
  10. Press ENTER to confirm setting. ZERO LED will go off, and loop will go to 20 mA.

#### 3.4.4.3.2 Lower S.G. greater than 1.0.

When S.G. of lower liquid is greater than 1.0, calibrate as follows (this example assumes upper S.G. = 0.78 and lower S.G. = 1.20):

1. Bring process up to operating temperature.
2. Establish water at the point on displacer equal to the upper S.G.  $\times 100\%$  (EX.  $0.78 \times 100\% = 78\%$ ).
3. Ensure there is no explosion hazard. With unit power on, remove cover.
4. Press ENTER key to start calibration. ZERO LED will light. Loop will go to 22 mA.
5. Press DOWN key to lock in 4 mA value. Zero LED will flash and remain on. Loop will stay at 22 mA.
6. Press ENTER to confirm setting. ZERO LED will go off, and loop will go to 4 mA.
7. Immerse displacer completely in water.
8. Determine the proper current setting for this calibration step using the following calculation:  $[(20 \text{ mA} - 4 \text{ mA}) \times (1.00 - \text{upper S.G.}) / (\text{lower S.G.} - \text{upper S.g.})] + 4 \text{ mA}$  (EX.  $[(20 \text{ mA} - 4 \text{ mA}) \times (1.00 - 0.78) / (1.20 - 0.78)] + 4 \text{ mA} = 12.38 \text{ mA}$ ).
9. Press ENTER key. ZERO LED will light. Loop will go to 20 mA.
10. Press UP key to lock in 20 mA value. ZERO LED will go off. SPAN LED will light. Loop will go to 20 mA.
11. Using UP and DOWN keys, toggle until loop signal reads 12.38 mA.
12. Press ENTER to confirm setting. The SPAN LED will go off.

### 3.5 Configuration Using HART

A HART (Highway Addressable Remote Transducer) remote unit, such as a HART handheld terminal (HHT) can be used to provide a communication link to the Digital ES II Modulelevel Transmitter. When connected to the control loop, the same system measurement readings shown on the transmitter are shown on the HHT. In addition, the HHT can be used to calibrate the transmitter.

If your HART communicator (HHT) has not been updated since January 1999, it will need to be updated to include the ES II Modulelevel V2 software (Device Descriptors). Contact your local HART Service Center if this is required.

#### 3.5.1 Connections

A HART communicator can be operated from a remote location by connecting to a remote junction or by connecting directly to the (+) and (-) terminal points at TB1 on the amplifier board in the electronics housing of the Digital ES II Modulelevel Transmitter.

HART uses the Bell 202 frequency shift key technique of high-frequency digital signals. It operates on the 4-20 mA loop and requires 250 ohms of minimum load resistance. A typical connection between a HHT and the Digital ES II Transmitter is illustrated in Figure 22.

#### 3.5.2 Display Menu

A typical communicator display is an 8 line by 21 character LCD. When connected, the top line of each on line menu displays the model (ES MOD) and its tag number or address. Usually, the bottom line is reserved for software defined function keys (F1-F4). For detailed operating information, consult the instruction manual provided with the HART communicator.

#### 3.5.3 Basic Field Calibration Using Hart HHC

1. Connect HART HHT per Figure 22.
2. Start up the unit.
3. Refer to the next page for the transmitter online menu. Open the menu by pressing the alphanumeric key 1, Device Setup, to display the second level menu.

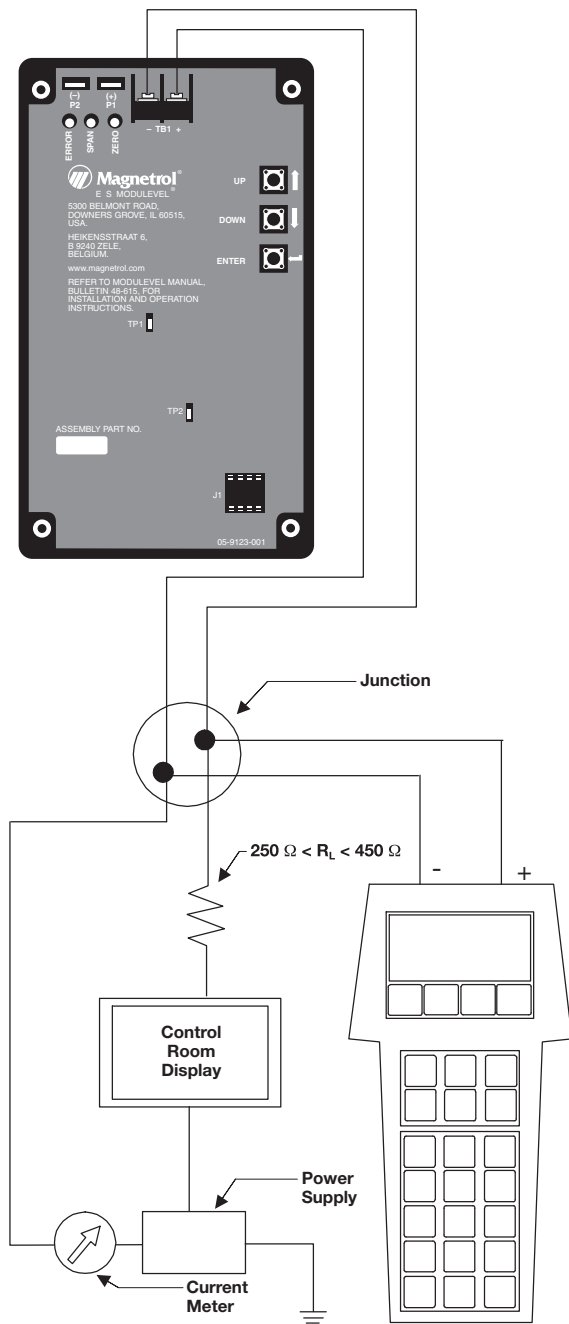
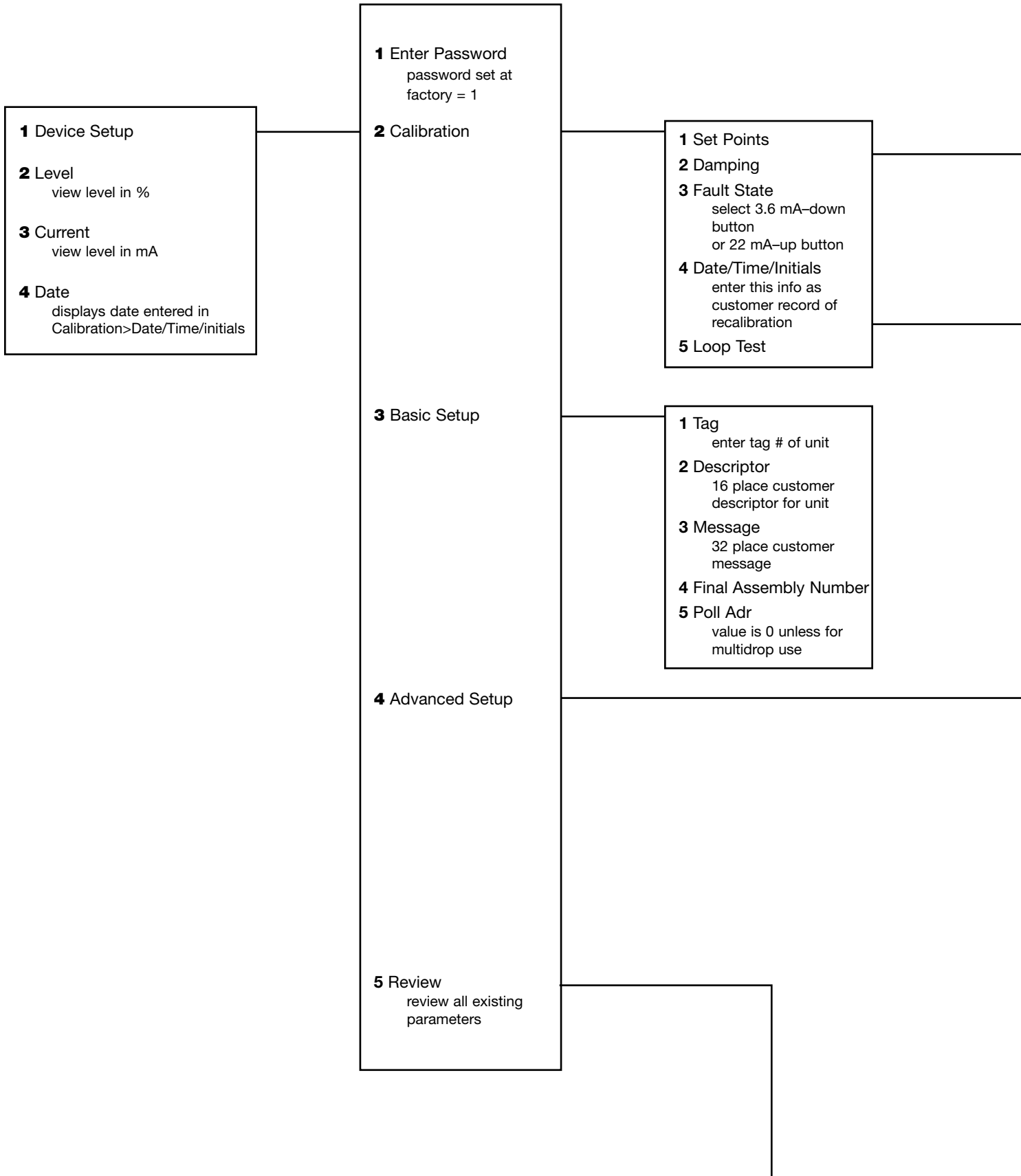


Figure 22

### Digital ES II/HART Communicator Connections

### 3.5.4 HART Menu



**1** 4 mA  
apply new 4 mA input

**2** 20 mA  
apply new 20 mA input

**3** 20 mA by %  
enter % of span vs.  
actual level

**4** End

**1** Set as 4 mA value  
current level will be new 4 mA level

**2** Read new value  
introduce a value that will match 4 mA

**3** Leave as found  
keep old 4 mA level

**1** Set as 20 mA value  
current level will be new 20 mA level

**2** Read new value  
Introduce a value that will match 20 mA

**3** Leave as found  
keep old 20 mA value

**1** 4 mA  
unit blocks at 4 mA

**2** 20 mA  
unit blocks at 20 mA

**3** Other  
enter a value between 3.6 and 22 mA

**4** End

**1** Set Dry Point  
for use when SG will be changed,  
dry point set with displacer hanging free  
completely out of liquid.

**2** LVDT %  
read out %

**3** Spec Grav  
set SG value

**4** Error Codes  
if value other than 0000, consult factory

**5** New password  
enter new password, or enter value "0"  
to disable password function

**6** Trim 4 mA Point  
factory set

**7** Trim 20 mA Point  
factory set

**8** 4 mA Trim Point  
factory set

**9** 20 mA Trim Point  
factory set

**10** Set Serial Number  
factory set

**1** Model

**2** Manufacturer

**3** Set Magnetrol S/N

**4** Dev id

**5** Tag

**6** Descriptor

**7** Message

**8** Damping

**9** Fault State

**10** Date

**11** Final Assembly

**12** Universal rev

**13** Fld dev rev

**14** Software rev

**15** Poll addr

**16** Number req preams

## 4.0 Reference Information

This section presents an overview of the operation of the Electronic Modulelevel Displacer Level Transmitter, information on troubleshooting common problems, listings of agency approvals, lists of replacement and recommended spare parts, and detailed physical, functional, and performance specifications.

### 4.1 Description

The Digital ES II and Analog EZ Modulelevels are advanced, intrinsically safe or explosion proof two-wire or four-wire instruments utilizing simple buoyancy principles to detect and convert liquid level changes into a stable 4–20 mA output signal. The linkage between the level sensing element and the output electronics provides a simple mechanical design and construction. The vertical in-line design of the transmitter results in low instrument weight and simplifies installation. The instrument comes in a variety of configurations and pressure ratings for varied applications.

The Digital ES II Modulelevel has micro-processor based electronics with HART compatible output, in addition to the standard 4–20 mA DC output. The Analog EZ Modulelevel provides a simple 4–20 mA output.

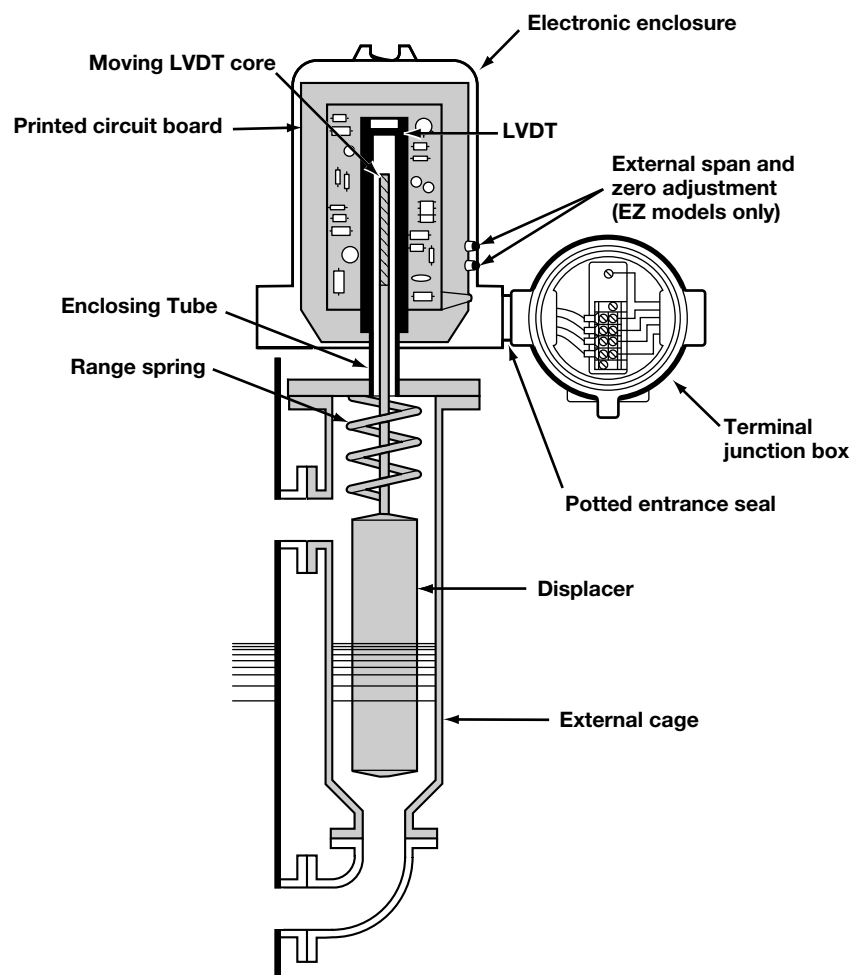


Figure 23  
Electronic Modulelevel  
Components

---

## 4.2 Theory of Operation

The Electronic Modulelevel Displacer Level Transmitter relies on the principles of buoyancy to convert mechanical movement to an electronic output. See Figure 23.

### 4.2.1 Displacer Buoyancy

The buoyancy force acting on an object is equal to the weight of the liquid displaced by the object. As the level changes, and more or less of the displacer is submerged in liquid, the buoyancy force on the displacer changes. This change is detected by the range spring from which the displacer hangs. The compression or elongation of the range spring, in turn, causes movement of the LVDT core mounted on the rigid stem attached to the spring.

### 4.2.2 LVDT

An LVDT is a linear variable differential transformer made up of a primary winding, two secondary windings and a special magnetic steel core. The primary winding and the two secondary windings form an open transformer. The secondary windings are positioned, one above each other, opposite the primary winding. The primary winding is powered so that when the magnetic steel core is positioned between the primary and one or both of the secondary windings, a current is induced in the secondary winding(s). By comparing the currents in the two secondary windings, the exact position of the core, and therefore the liquid level, can be measured.

## 4.3 Troubleshooting

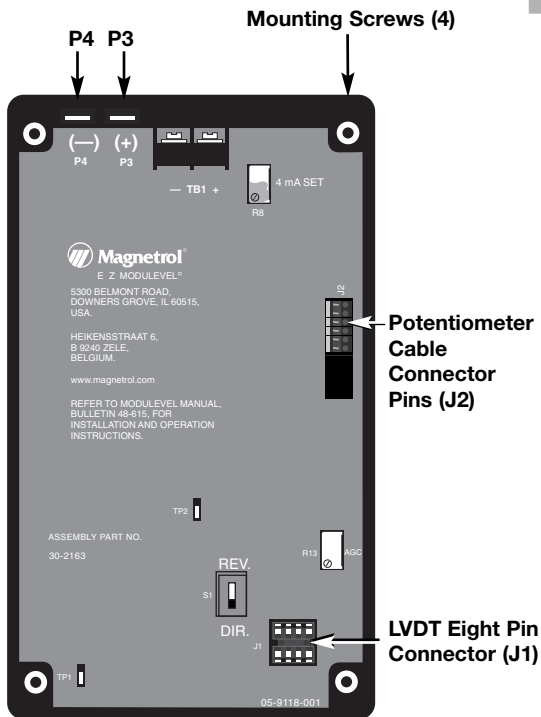
The Electronic Modulelevel Displacer Level Transmitter is designed and engineered for trouble-free operation over a wide range of operating conditions. Common transmitter problems are discussed in terms of their symptoms and corrective actions as recommended.

**WARNING!** Explosion hazard. Do not connect or disconnect equipment unless power has been switched off or the area is known to be non-hazardous.

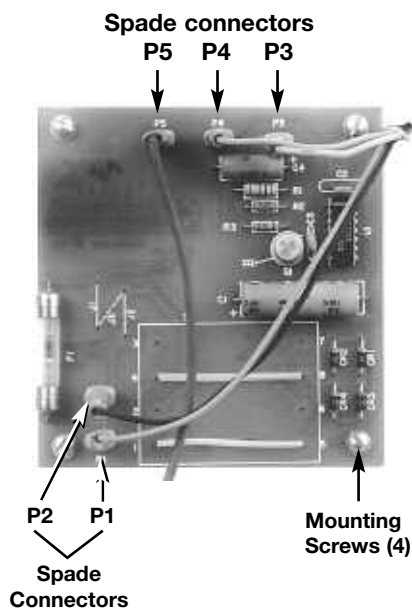
The table on the next page provides information on how to troubleshoot transmitter-level problems.

Symptom	Problem	Solution
No loop current	Power supply not turned on.	Turn on power.
	Insufficient source voltage.	The ES II requires a minimum of 12 VDC at terminals TB1 and TB2 while the EZ requires a minimum of 12 VDC at terminals P3 and P4 on amplifier board.
	Wires broken/improperly connected.	Check wiring.
	Defective PC board.	Replace PC board. See <i>Section 4.4.1 or 4.5.1.</i>
Zero point cannot be set to 4.00 mA at low level.	Incorrect supply.	Check power supply.
	Zero incorrectly set.	Recalibrate 0% level.
	Displacer hanging up.	Verify proper and level installation.
Span point cannot be increased to 20.00 mA at high level.	Incorrect supply.	Check power supply.
	Span incorrectly set.	Recalibrate unit.
	Displacer hanging up.	Verify proper and level installation.
	Excessive loop resistance.	Increase power supply voltage, or decrease loop resistance (For Digital ES II, max 545 ohms @ 24 VDC, 450 ohms for HART; for Analog EZ, max 480 ohms @ 24VDC).
Span point cannot be decreased to 20.00 mA at high level.	Span incorrectly set.	Recalibrate unit.
	Displacer hanging up.	Verify proper and level installation.
Loop current oscillates or hunts.	Waves or disturbances in medium.	Adjust damping via HART (ES II) or install stilling well. See <i>Section 3.5.4.</i>
Loop current randomly unstable.	Waves or disturbances in medium.	Adjust damping via HART.
	Power supply unstable.	Repair or replace power supply.
	Electrical interference (RFI).	Consult factory for assistance.
Loop current exceeds 20.00 mA.	Incorrect calibration.	Recalibrate unit.
	Material level greater than 100%.	No action required.
	Supply voltage out of limits at transmitter.	Check power supply. Allowable voltage for ES II or EZ is between 12 and 36 VDC,
	Excessive temperature at transmitter electronics.	Use remote transmitter mounting.
	Loop current exceeds 22.00 mA.	Check power supply (+) and (-) for reverse wiring.
Loop current less than 4.00 mA.	Incorrect calibration.	Recalibrate unit.
	Material level less than 0%.	No action required.
	Supply voltage out of limits at transmitter.	Adjust power supply or reduce loop resistance.
	Excessive temperatures at transmitter electronics.	Use remote transmitter mounting.
Loop current 22 mA or 3.6 mA fault indication (ES II only).	Stem is broken, LVDT core is missing, LVDT wire is broken or unplugged or circuitry failure has occurred.	Verify the unit.
Non-linear output.	Incorrect calibration.	Recalibrate unit.
	Excessive loop resistance.	Increase power supply voltage or decrease loop resistance.
	Displacer hanging up.	Verify proper and level installation.

## 4.4 Maintenance of Analog EZ Modulelevel



**Figure 24**  
Analog EZ Transmitter PC Board Connections



**Figure 25**  
Analog EZ Power Supply PC Board Connections

### 4.4.1 Replacing Transmitter PC Board

Refer to Figure 24 during this procedure.

1. Remove power from the unit.
2. Remove transmitter housing cover.

To remove old transmitter board:

3. Remove the two wires from spade connectors P3 and P4 and shield wire from the board mounting screw on the transmitter PC board.
4. Unplug the potentiometer cables from the PC board connector pins at J2.
5. Unplug the LVDT eight pin connector from the socket at J1.
6. Clip the plastic tie wrap which holds the cable to the PC board.
7. Remove two screws which secure the PC board bracket to housing base and carefully remove board / bracket assembly.
8. Remove the four screws which hold the PC board to the bracket.
9. Carefully remove the transmitter PC board from the transmitter housing.
10. Install new PC board by reversing above steps. Be certain that the red wire is attached to P3 and the black wire is attached to P4.

### 4.4.2 Replacing Power Supply PC Board (120 and 240 VAC controls only)

Refer to Figure 25 during this procedure.

1. Remove power from the unit.
2. Remove transmitter housing cover.

To remove old power supply board:

3. Mark the five wires connected to P1 through P5 and then remove the wires from these connectors.
4. Remove the four screws which hold the PC board to the bracket.
5. Carefully remove the power supply PC board from the transmitter housing.
6. Install new PC board by reversing above steps. Be certain that each wire is connected to the same spade connector as on the original PC board.

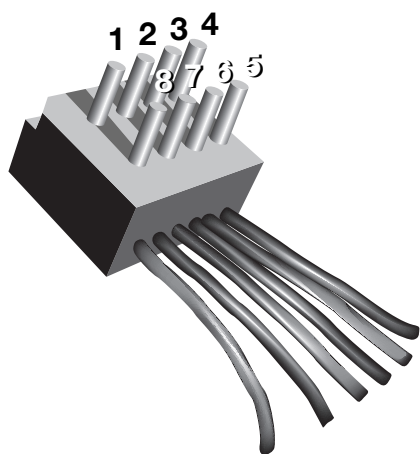
---

### 4.4.3 Replacing LVDT

1. Remove power from the unit.
2. Remove the transmitter housing cover.

To remove old LVDT:

3. Locate the black wire which runs from the top of the LVDT to the lower right hand corner of the transmitter PC board. Remove the eight pin connector on this wire from J1 on the transmitter PC board.
4. Remove the c-ring above the LVDT on the enclosing tube using a snap ring pliers.
5. Carefully slide the LVDT from the enclosing tube. If necessary, clip the plastic tie wrap on the transmitter PC board.
6. Install new LVDT by reversing the above steps.



**Figure 26**  
**LVDT Eight Pin Connector**

### 4.4.4 Checking the LVDT Winding Resistance

Refer to Figure 26 during this procedure.

1. Remove power from the unit.
2. Remove the transmitter housing cover.
3. Locate the black wire which runs from the top of the LVDT to the lower right hand corner of the transmitter PC board. Remove the eight pin connector on this wire from J1 on the PC board.
4. Using a multimeter, check the primary winding by verifying that pins 2 and 6 of the eight pin connector have approximately 78 to 117 ohms resistance.
5. Check the secondary winding by verifying that pins 1 and 5 or pins 4 and 8 of the eight pin connector have approximately 72 to 109 ohms resistance.
6. If the winding resistance is out of range, replace LVDT.

---

## 4.5 Maintenance of Digital ES II Modulelevel

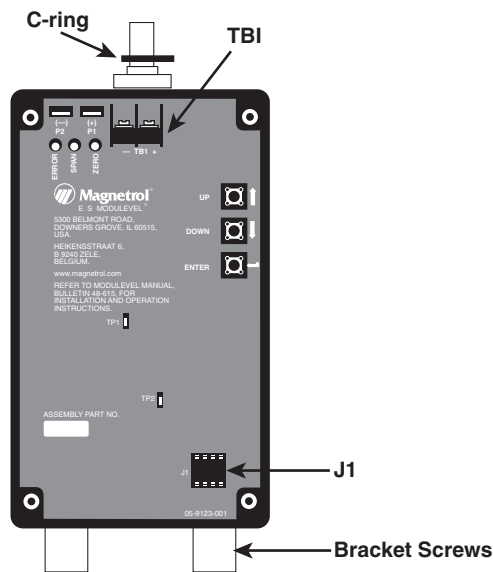
### 4.5.1 Replacing Transmitter PC Board

Refer to Figure 27 during this procedure.

1. Remove power from the unit.
2. Remove transmitter housing cover.

To remove old board:

3. Remove two screws which secure the PC board bracket to the housing base.
4. Remove two wires from TB1 on the PC board.



**Figure 27**  
**Digital ES II Transmitter PC**  
**Board Mounting**

5. Unplug the LVDT eight pin connector from the socket at P1 on the PC board.
6. Clip the plastic tie wraps which hold the cable to the PC board.
7. Remove the four screws which hold the PC board to the bracket.
8. Remove the c-ring from LVDT using snap ring pliers.
9. Carefully remove the transmitter PC board from the transmitter housing.
10. Install new PC board by reversing above steps. Be certain that the red wire is attached to the (+) terminal at TBI and the black wire is attached to the (-) terminal at TBI.

#### 4.5.2 Replacing LVDT

1. Remove power from the unit.
2. Remove the transmitter housing cover.

To remove old LVDT:

3. Locate the black wire which runs from the top of the LVDT to the lower right hand corner of the transmitter PC board. Remove the eight pin connector on this wire from J1 on the PC board.
4. Remove the c-ring above the LVDT on the enclosing tube using a snap ring pliers.
5. Carefully slide the LVDT from the enclosing tube. If necessary, clip the plastic tie wrap on the transmitter PC board.
6. Install new LVDT by reversing the above steps.


#### 4.5.3 Checking the LVDT Winding Resistance

Refer to Figure 26 during this procedure.


1. Remove power from the unit
2. Remove the transmitter housing cover.
3. Locate the black wire which runs from the top of the LVDT to the lower right hand corner of the transmitter PC board. Remove the eight pin connector on this wire from J1 on the PC board.
4. Using a multimeter, check the primary winding by verifying that pins 2 and 6 of the eight pin connector have approximately 78 to 117 ohms resistance.
5. Check the secondary winding by verifying that pins 1 and 5 or pins 4 and 8 of the eight pin connector have approximately 72 to 109 ohms resistance.
6. If the winding resistance is out of range, replace LVDT.

## 4.6 Agency Approvals


### 4.6.1 FM (Factory Mutual)

Model		Approval
<b>XEXX-XXXX</b> with transmitter codes:  	<b>EZA</b> , B, C, E, F, G, L, N	<b>Explosion Proof</b> Class I, Div. 1; Groups A, B, C, D Class II, Div. 1; Groups E, F, G Class III, NEMA 4X
	<b>ESA</b> , E, F, G, 7, 9	
	<b>GZH</b> , K, Q, R, S, T, U, V, 2, 3, 5, 6	
	<b>GSH</b> , K, Q, T, 4, 7	
	<b>RZW</b> , X	
	<b>RSW</b> , X, 4	
<b>XEXX-XXXX</b> with transmitter codes:	<b>RZQ</b> , T	<b>Explosion Proof with Intrinsically Safe Connections</b> Class I, II, III, Div. 1; Groups B, C, D, E, F, G Nema 4X Entity
	<b>RSQ</b> , T, Z	
<b>EXX-XXXX</b> with transmitter codes:	<b>EZD</b> , H, I, K	<b>Intrinsically Safe</b> Class I, Div. 1; Groups B, C, D Class II, Div. 1; Groups E, F, G Class III, NEMA 4X Entity
	<b>ESD</b> , H, I, J, K, 8, 9	
<b>EXX-XXXX</b> with transmitter codes:	<b>EZA</b> , G	<b>Non-Incendive</b> suitable for: Class I, Div. 2; Groups A, B, C, D Class II, Div. 2; Groups F, G Class III, Div. 2; NEMA 4X
	<b>ESA</b> , E, F, G, 7, 9	
	<b>GZH</b> , K, Q, T ①	
	<b>GSH</b> , K, Q, T, 4, 7 ①	
	<b>RZW</b> , X	
	<b>RSW</b> , X, 4	

## 4.6.2 CSA (Canadian Standards Association)

Model		Approval
<b>XE5X-XXXX</b> with transmitter codes:	<b>EZA</b> , B, C, E, F, G, L, N <b>ESA</b> , E, F, G, 7, 9 <b>GZH</b> , K, Q, R, S, T, U, V, 2, 3, 5, 6 <b>GSH</b> , K, Q, T, 4, 7 <b>RZW</b> , X <b>RSW</b> , X, 4	<b>Explosion Proof</b> Class I, Div. 1; Groups B, C, D Class II, Div. 1; Groups E, F, G Class III, Type 4X
		
<b>E5X-XXXX</b> with transmitter codes:	<b>EZD</b> , H, I, K <b>ESD</b> , H, I, J, K, 8 <b>GZH</b> , K, Q, T ② <b>GSH</b> , K, Q, T, 4, 7 ② <b>RZQ</b> , T <b>RSQ</b> , T, Z	<b>Intrinsically Safe</b> Class I, Div. 1; Groups A, B, C, D Class II, Div. 1; Groups E, F, G Class III, Type 4X Entity
<b>E5X-XXXX</b> with transmitter codes:	<b>EZD</b> , H, I, K <b>ESD</b> , H, I, J, K, 8 <b>GZH</b> , K, Q, T ② <b>GSH</b> , K, Q, T, 4, 7 ② <b>RZQ</b> , T <b>RSQ</b> , T, Z	<b>Non-Incendive</b> suitable for: Class I, Div. 2; Groups A, B, C, D Class II, Div. 2; Groups E, F, G Class III, Type 4X

## 4.6.3 ATEX (European Directive for Explosion Protection)

Model		Approval
<b>ATEX</b>	<b>XEXX-XXXX, EXX-XXXX</b> with transmitter codes <b>EZA</b> , E, F, G <b>ESA</b> , E, F, G, 7, 9 <b>RZW</b> , X <b>RSW</b> , X, 4	<b>Explosion Proof</b> ③ ATEX Ex II 1/2 G EEx d IIC T6
		
	<b>EXX-XXXX</b> with transmitter codes <b>ESD</b> , I, H, K <b>RSQ</b> , T	<b>Intrinsically Safe</b> ④ ATEX Ex II 1 G EEx ia IIC T6
	<b>EXX-XXXX</b> with transmitter codes <b>ESJ</b> , 8 <b>RSZ</b>	<b>Intrinsically Safe</b> ④ ATEX Ex II 1 G EEx ia IIC T5

① Field wiring must be installed in conduit.

② If IS or NI CSA nameplate is required, this must be specified at time of order placement.

③ ATEX EP approval available on standard 900#, 1500#, and 2500# models. 150#, 300#, and #600 models require modification for ATEX EP approval and must be "X'd" for a heavy wall e-tube.

④ Entity parameters for ATEX EEx ia installation:

Ci = 5 nF, Li = 800 μH

Ui = 28.4 V, Pi = 0.67 W or

Ui = 26.4 V, Li = 99 mA, Pi = 0.66 W



These units have been tested to EN 50081-2 and EN 50082-2 and are in compliance with the EMC Directive 89/336/EEC.

## 4.7 Parts

### 4.7.1 Replacement P.C. Boards

		① Replacement Electronic Modulelevel Boards		
<b>Digital ES</b>		<b>Serial Number Format</b>	<b>(6 digits)-(2 digits)-(3 digits)</b>	<b>6 or 7 digits</b>
		<b>Date of Manufacture</b>	<b>1998 - present</b>	<b>1995 - 1999</b>
		<b>P.C. Board Description</b>	<b>Potted module</b>	<b>Through hole</b>
<b>Supply Voltage</b>	<b>Transmitter Mounting</b>	<b>Transmitter Code</b>	<b>ES II board</b>	<b>ES I board</b>
24 VDC	Integral	ESA/ESD/ESG/ESI/ESE/ESH/ESF	89-9113-001 ①	
		ESJ/ES9/ESK/ES7/ES8		
	Remote	ES1/ES4/GSH/GSK		
		GS7		
		ESQ/EST/GSQ/GST		
		GS4		
HT-Integral	RSQ/RSW/RST/RSX/RS4/RSZ			

		① Replacement Electronic Modulelevel Boards		
<b>Analog EZ</b>		<b>Serial Number Format</b>	<b>(6 digits)-(2 digits)-(3 digits)</b>	<b>6 or 7 digits</b>
		<b>Date of Manufacture</b>	<b>1996 - present</b>	<b>1984 - 1997</b>
		<b>P.C. Board Description</b>	<b>Six pin potentiometer connector</b>	<b>Ten pin potentiometer connector</b>
<b>Supply Voltage</b>	<b>Transmitter Mounting</b>	<b>Transmitter Code</b>	<b>New EZ board</b>	<b>Original EZ board</b>
24 VDC	Integral	EZA/EZG/EZE/EZF	89-7826-004	89-7826-001
24 VDC		EZD/EZI/EZH	89-7826-004	89-7826-001 ②
120 VAC		EZB/EZL	89-7826-005	89-7826-002
240 VAC		EZC/EZN	89-7826-006	89-7826-003
24 VDC	Remote	EZ1/EZ4/GZH/GZK	89-7826-004	89-7826-001
120 VAC		EZ2/EZ5/GZ2/GZ5	89-7826-005	30-2163-002
240 VAC		EZ3/EZ6/GZ3/GZ6	89-7826-006	89-7826-003
24 VDC		EZQ/EZT/GZQ/GZT/GZZ	89-7826-004	89-7826-001
120 VAC		EZR/EZU/GZR/GZU	89-7826-005	89-7826-002
240 VAC		EZS/EZV/GZS/GZV	89-7826-006	89-7826-003
24 VDC	HT-Integral	RZW/RZX/RZQ/RZT	89-7826-004	n/a

① All digital ES boards are to be replaced with ES II transmitter boards as indicated.

② CENELEC IS units require complete transmitter head replacement if PC board or LVDT is required.

## 4.7 Parts

### 4.7.2 Transmitter Head Parts

	② LVDT <sup>®</sup> Assembly	③ Meter Assembly	④ Transmitter/LVDT Housing	⑤ Junction Box	⑥ Housing O-rings	Junction/Meter Board (not shown)
ESA	89-7827-001	N/A	89-7830-002	89-7828-005	89-6562-001	Z30-2194-001
ESG		37-3308-001		89-7828-006		
ES9		37-3310-001				
EZA	89-7827-001	N/A	89-7830-001	89-7828-001	89-6562-001	N/A
EZB				89-7828-002		
EZC						
EZG	89-7827-001	37-3145-002	89-7830-001	89-7828-003	89-6562-001	N/A
EZL				89-7828-004		
EZN						
ESE	89-7827-006	N/A	89-7830-002	89-7828-005	89-6562-001	Z30-2194-001
ESF		37-3308-001		89-7828-006		
ES7		37-3310-001				
EZE	30-2135-002	N/A	89-7830-001	89-7828-001	89-6562-001	N/A
EZF		37-3145-002		89-7828-003		
GSH	89-7827-003	N/A	89-7830-002 and 89-7830-003	89-7828-005	89-6562-001 QTY 2	Z30-2194-001
GSK		37-3308-001		89-7828-006		
GS7		37-3310-001				
GSQ	89-7827-004	N/A	89-7830-002 and 89-7830-003	89-7828-005	89-6562-001 QTY 2	Z30-2194-001
GST		37-3308-001		89-7828-006		
GS4		37-3310-001				
GZH	89-7827-003	N/A	89-7830-001 and 89-7830-003	89-7828-001	89-6562-001 QTY 2	N/A
GZ2				89-7828-002		
GZ3						
GZK	89-7827-003	37-3145-002	89-7830-001 and 89-7830-003	89-7828-003	89-6562-001 QTY 2	N/A
GZ5				89-7828-004		
GZ6						
GZQ	89-7827-004	N/A	89-7830-001 and 89-7830-003	89-7828-001	89-6562-001 QTY 2	N/A
GZR				89-7828-002		
GZS						
GZT	89-7827-004	37-3145-002	89-7830-001 and 89-7830-003	89-7828-003	89-6562-001 QTY 2	N/A
GZU				89-7828-004		
GZV						
RSW	89-7827-004	N/A	89-7830-004 and 89-7830-003	89-7828-005	89-6562-001 QTY 2	Z30-2194-001
RSX		37-3308-001		89-7828-006		
RS4		37-3310-001				
RZW	89-7827-004	N/A	89-7830-005 & 89-7830-003	89-7828-001	89-6562-001 QTY 2	N/A
RZX		37-3145-002		89-7828-003		
ESD	89-7827-001	N/A	04-9111-001 cover only	04-9113-001 cover only	89-6562-001	Z30-2194-001
ESH	89-7827-006					
RSQ*	89-7827-004					
ESI	89-7827-001	37-3308-001	04-9111-001 cover only	36-3908-003 cover only	89-6562-001	Z30-2194-001
ESK	89-7827-006					
RST	89-7827-004					
ESJ	89-7827-001	37-3310-001	04-9111-001 cover only	36-3908-003 cover only	89-6562-001	Z30-2194-001
ES8	89-7827-006					
RSZ*	89-7827-004					
EZD	89-7827-001	N/A	04-9111-001 cover only	04-9113-001 cover only	89-6562-001	N/A
EZH	30-2135-002					
RZQ*	89-7827-004					
EZI	89-7827-001	37-3145-002	04-9111-001 cover only	36-3908-001 cover only	89-6562-001	N/A
EZK	30-2135-002					
RZW*	89-7827-004					

\* Requires quantity 2 of Transmitter/LVDT Housing and Housing O-rings

### 4.7.3 Recommended Spare Parts

Item	Description	Part Number
1	Transmitter PC board assembly	See replacement parts chart, Section 4.7.1.
2	Displacer	See replacement parts chart, Section 4.7.4.

## 4.7.4 Mechanical Replacement Parts

⑦

E-tube kit		
	Standard	High Temperature
CS to 600#	89-5944-001	89-5944-004
SS to 600#	89-5944-002	89-5944-007
CS - 900#	89-5944-002	89-5944-003
CS 1500# & up	89-5944-005	89-5944-006

⑧

E-tube Gasket	
All Pressures	12-1204-001

⑨

Flange/Flange Assembly						
	150#	300#	600#	900#	1500#	2500#
3" CS 0.5	89-4217-001	89-4219-001	89-4221-001	n/a	n/a	n/a
3" CS 1.0/2.0	89-4218-001	89-4220-001	89-4222-001	n/a	n/a	n/a
4" CS 0.5	Z31-4804-007	Z31-4804-008	Z31-4804-009	n/a	n/a	n/a
4" CS 1.0/2.0	Z31-4804-010	Z31-4804-011	Z31-4804-012	Z04-8606-001	Z04-8606-002	Z04-8606-003
6" CS 0.5	Z31-4804-013	Z31-4804-014	Z31-4804-015	n/a	n/a	n/a
6" CS 1.0/2.0	Z31-4804-016	Z31-4804-017	Z31-4804-018	Z04-8606-004	Z04-8606-005	Z04-8606-006
3" SS 0.5	89-4238-001	89-4238-003	89-4238-005	n/a	n/a	n/a
3" SS 1.0/2.0	89-4238-002	89-4238-004	89-4238-006	n/a	n/a	n/a
4" SS 0.5	Z31-4806-007	Z31-4806-008	Z31-4806-009	n/a	n/a	n/a
4" SS 1.0/2.0	Z31-4806-010	Z31-4806-011	Z31-4806-012	n/a	n/a	n/a
6" SS 0.5	Z31-4806-013	Z31-4806-014	Z31-4806-015	n/a	n/a	n/a
6" SS 1.0/2.0	Z31-4806-016	Z31-4806-017	Z31-4806-018	n/a	n/a	n/a

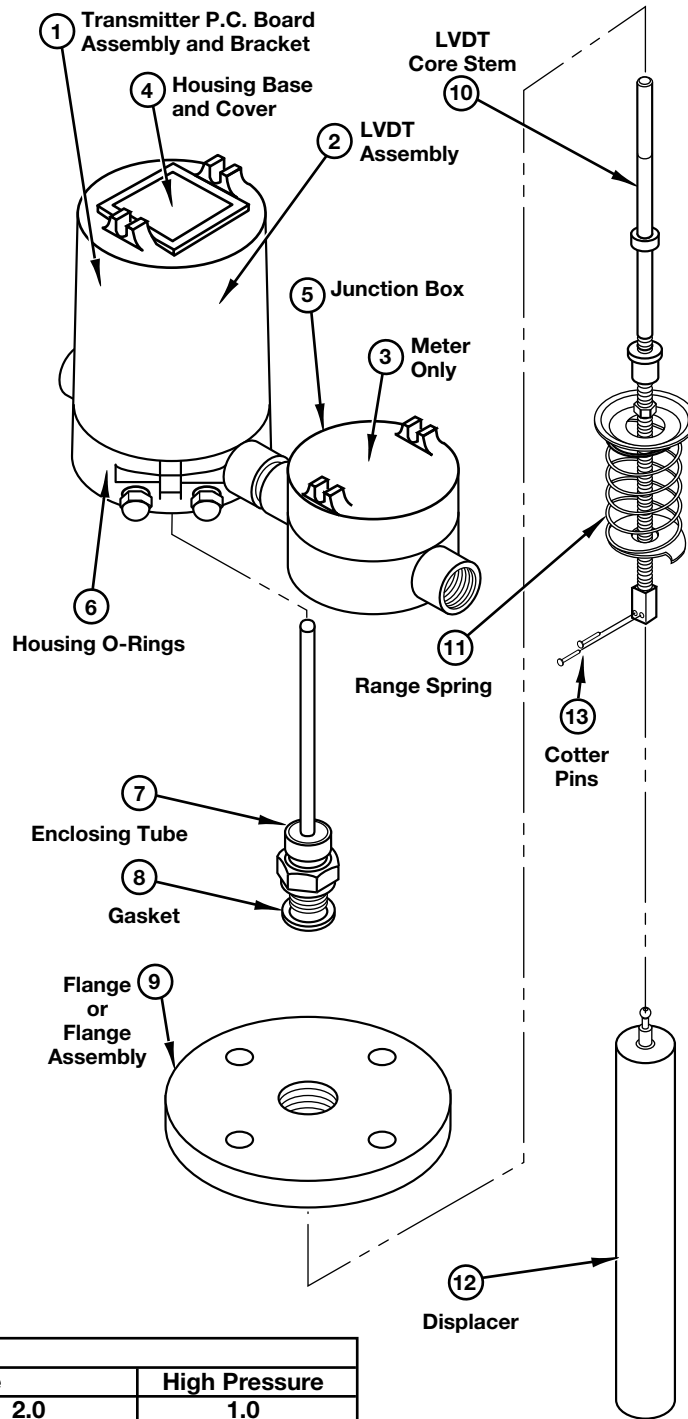
⑩

Stem Assembly				
Pressure	E-tube	0.5 SG	1.0 SG	2.0 SG
600# or less	standard	32-5841-003	32-5841-004	32-5841-004
600# or less	High Temp	32-5841-005	32-5841-006	32-5841-006
4" 900#	standard	n/a	32-5855-001	n/a
4" 900#	High Temp	n/a	32-5855-006	n/a
6" 900#	standard	n/a	32-5855-002	n/a
6" 900#	High Temp	n/a	32-5855-007	n/a
4" 1500#	standard	n/a	32-5855-002	n/a
4" 1500#	High Temp	n/a	32-5855-007	n/a
6" 1500#	standard	n/a	32-5855-004	n/a
6" 1500#	High Temp	n/a	32-5855-009	n/a
4" 2500#	standard	n/a	32-5855-003	n/a
4" 2500#	High Temp	n/a	32-5855-008	n/a
6" 2500#	standard	n/a	32-5855-005	n/a
6" 2500#	High Temp	n/a	32-5855-010	n/a

⑪

Spring Assembly				
	0.5 SG	1.0 SG	2.0 SG	Hi Press 1.0 SG
CS Low Temp	32-8129-003	32-8129-001	32-8129-005	32-8120-002
SS Low Temp	32-8129-004	32-8129-002	32-8129-006	n/a
CS/SS Hi Temp	32-8129-008	32-8129-007	32-8129-009	32-8120-002

Head Flange- Gasket Only (not pictured)						
	150#	300#	600#	900#	1500#	2500#
3"	12-1301-17	12-1301-018	12-1204-021	n/a	n/a	n/a
4"	n/a	n/a	n/a	12-1204-009	12-1204-010	12-1204-011



⑫

Displacer			
	Low Pressure		High Pressure
	0.5/1.0	2.0	1.0
14"	89-6125-001	89-6126-001	89-6125-010
32"	89-6125-002	89-6126-002	89-6125-011
48"	89-6125-003	89-6126-003	89-6125-012
60"	89-6125-004	89-6126-004	89-6125-013
72"	89-6125-005	89-6126-005	n/a
84"	89-6125-006	89-6126-006	n/a
96"	89-6125-007	89-6126-007	n/a
108"	89-6125-008	89-6126-008	n/a
120"	89-6125-009	89-6126-009	n/a

⑬

Cotter pins	
All Units	10-5203-001

---

## 4.7.5 Upgrade to ESII Electronics

### 4.7.5.1 Procedure for Conversion of Smart ES Electronics to Digital ES II Electronics

#### **REMOVAL OF THE ES TRANSMITTER BOARD:**

1. Remove power from the Smart ES unit.
2. Remove the transmitter housing cover.
3. Remove the two screws that secure the PC board and bracket assembly to the housing base. Save these screws.
4. Using snap ring pliers, remove the c-ring on the enclosing tube above the LVDT.
5. Slide the board/bracket assembly up and off of the e-tube.
6. Remove the shield over the transmitter PC board by removing the two screws in the upper corners of the board that hold it in place. Discard the shield and screws.
7. Remove the power wires from terminal TB1 on the board.
8. Remove the LVDT eight pin connector from socket P1 on the board.
9. Clip the plastic tie-wrap that holds the cable to the board.
10. Remove and discard the PC board and bracket assembly.

#### **INSTALLATION OF THE ES II REPLACEMENT BOARD:**

1. Have on hand an ES II replacement board kit, p/n 89-9113-001.
2. Connect the power wires to the board at terminal TB1. Ensure that the red wire is attached to the (+) terminal and the black wire to the (-) terminal.
3. Plug the LVDT eight pin connector into the new board at socket J1.
4. Slide the board and bracket assembly down on the e-tube until the bracket rests in the housing base.
5. Secure the bracket to the housing base using the two screws that originally held it in place.
6. Replace the c-ring on the enclosing tube above the LVDT.
7. Replace the transmitter housing cover.
8. Apply power and check for output signal.
9. Recalibrate the transmitter as described in Sections 3.4 & 3.5.

#### 4.7.5.2 Procedure for Conversion of EZ Electronics to Digital ES II Electronics

##### REMOVAL OF THE EZ TRANSMITTER:

1. Remove power from the EZ unit.
2. Remove the transmitter and terminal housing covers.
3. Disconnect the field wiring in the terminal strip housing.
4. Unplug the LVDT wiring from the 8-pin connector at P1.
5. Remove the c-ring on the enclosing tube above the LVDT using snap ring pliers.
6. Slide the LVDT up, off the enclosing tube. It may be necessary to clip the wiring tie-wrap from the PC board.
7. Remove the white plastic positioner ring at the base of the enclosing tube.
8. Loosen the set screws in the hub of the housing base, and carefully lift the entire assembly off the enclosing tube.

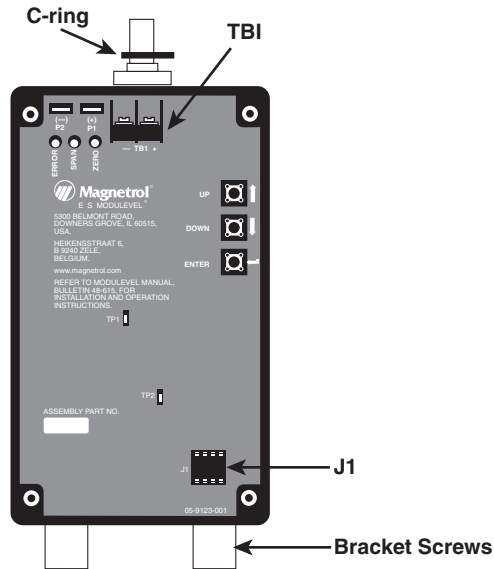


Figure 28

##### INSTALLATION OF THE ES II REPLACEMENT:

1. Remove the dummy enclosing tube (if provided) from the new ES II housing assembly.
2. Remove the transmitter and terminal housing covers.
3. Lower the complete ES II assembly onto the existing enclosing tube, being careful not to bend the enclosing tube. Make sure the housing set screws are loose so that the assembly fits tightly to the enclosing tube nut. As you lower the assembly, guide the PC board assembly mounting bracket onto the enclosing tube.
4. Replace the white plastic positioner on the enclosing tube making sure it is snug against the enclosing tube base; then, slide the LVDT down the enclosing tube until it rests firmly on the white plastic positioner.
5. Replace the c-ring at the top of the enclosing tube.
6. Connect the 8-pin LVDT into the socket at J1.
7. Connect the field wiring to the terminals in the terminal housing. Check the terminal markings for +/- polarity.
8. Replace the transmitter housing cover.
9. Apply power and check for output signal.
10. Calibrate the transmitter as described in Sections 3.4 & 3.5.

## 4.8 Specifications

### 4.8.1 Functional

<i>Measurement principle</i>	Buoyancy – continuous displacement utilizing a precision range spring
<b>Input</b>	
<i>Measured variable</i>	Level, determined by LVDT core movement affected by buoyancy force changes on continuous displacer
<i>Physical Range</i>	Up to 120" (300 cm) based on displacer length
<b>Output (Digital ES II)</b>	
<i>Type</i>	Analog 4 to 20 mA direct or reverse acting with HART® digital signal
<i>Range</i>	Analog 3.8 to 20.5 mA useable Digital 0 to 100%
<i>Loop Resistance (maximum)</i>	545 Ohms @ 24 VDC
<i>Fault</i>	3.6 or 22 mA, selectable
<i>Damping</i>	Adjustable 0-60 seconds
<i>Sampling Rate</i>	Transmitter 15 times per second Digital Meter 1.33 times per second
<b>User Interface (Digital ES II)</b>	
<i>Keypad</i>	3 calibration buttons (up, down, enter)
<i>Indication</i>	3 LED's on PCB for calibration and functional checks
<i>Digital communication</i>	HART Version 5.x compatible
<b>Power (Digital ES II)</b>	
<i>Measured at instrument terminals</i>	12 to 36 VDC
<b>Output (Analog EZ)</b>	
<i>Type</i>	Analog 4 to 20 mA direct or reverse acting
<i>Range</i>	Analog 4 to 20 mA useable
<i>Loop Resistance (maximum)</i>	480 ohms @ 24 VDC
<i>Fault</i>	22 mA
<b>User Interface (Analog EZ)</b>	
<i>Potentiometers</i>	Zero + Span controls
<i>Action</i>	Direct/Reverse switch
<b>Power (Analog EZ)</b>	
<i>Measured at instrument terminals</i>	12 to 36 VDC 120 VAC, 50/60 Hz 240 VAC, 50/60 Hz
<b>Housing</b>	
<i>Material</i>	Polymer coated cast iron
<i>Cable entry</i>	1" NPT

---

## Chamber

<i>Materials</i>	Carbon steel 316/316L stainless steel
<i>Wetted parts</i>	304/304L and 316/316L (900# and greater) and Inconel (spring) 316/316L (600# and less) and Inconel (spring)
<i>Process connections</i>	Tank Top: 3", 4", 6" ANSI Flange Chambered: 1½", 2" NPT 1½", 2" Socketweld 1½", 2" ANSI Flanges

## Process Conditions

<i>Process temperature range</i> *	Steam applications: -20° F to +500° F (+260° C) Non-steam applications: -20° F to +600° F (-29°C to +315° C)
<i>Process pressure range</i>	4265 psig @ +100° F (294 bar @ +38° C)

## Environmental

<i>Electronics operating temperature</i>	-40° F to +160° F (-40° C to +70° C)
<i>Display function operating temperature</i>	-4° F to +160° F (-20° C to +70° C)
<i>Storage temperature</i>	-40° F to +185° F (-40° C to +85° C)
<i>Electromagnetic compatibility</i>	Meets CE Requirements (EN 50081-2, EN 50082-2)

---

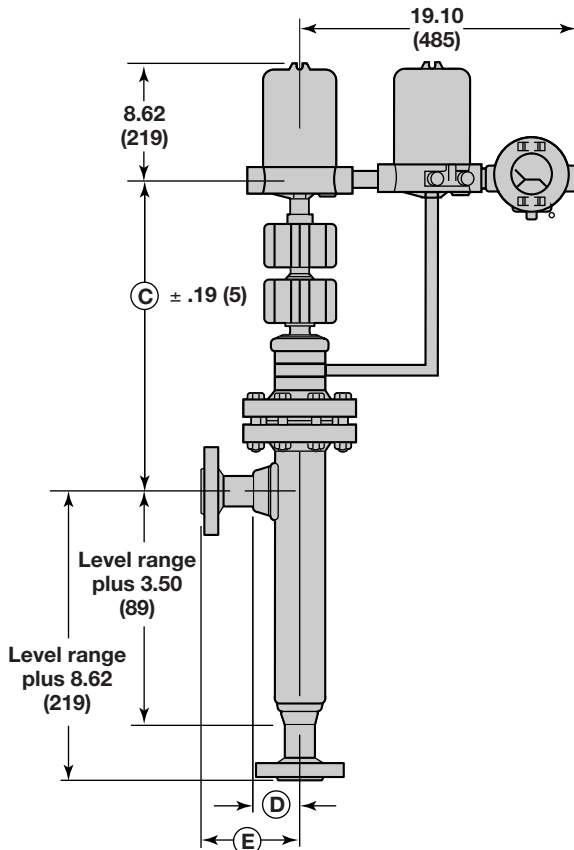
## 4.8.2 Performance

<i>Linearity (independent)</i>	LVDT: +/- 0.25% of full span Mechanical/electrical: +/- 0.25% of full span
<i>Repeatability</i>	+/-0.20% of full span
<i>Resolution</i>	0.05 % of range ± 1 digit
<i>Ambient temperature effect</i>	Maximum zero shift is 0.031% of effect/°F
<i>Operating Temp. range:</i>	-40° to +160° F (-40° to +70° C)
<i>Digital Meter Temp. Range:</i>	-4° to +160° F (-20° to +70° C)
<i>Storage Temp. Range:</i>	-40° to +185° F (-40° to +85° C)
<i>Electromagnetic Compatibility:</i>	Meets CE Requirements (EN 50081-2, EN 50082-2)

\* Maximum process temperatures are based on ambient temperatures less than or equal to +120° F (+49° C). Higher ambient temperatures require reduced process temperatures.

### 4.8.3 Physical

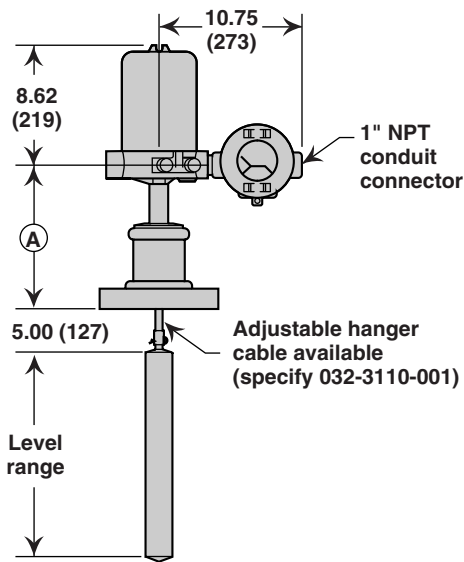
#### Dimensional specifications for standard pressure models E61, E62, E63, E64, E65, E66



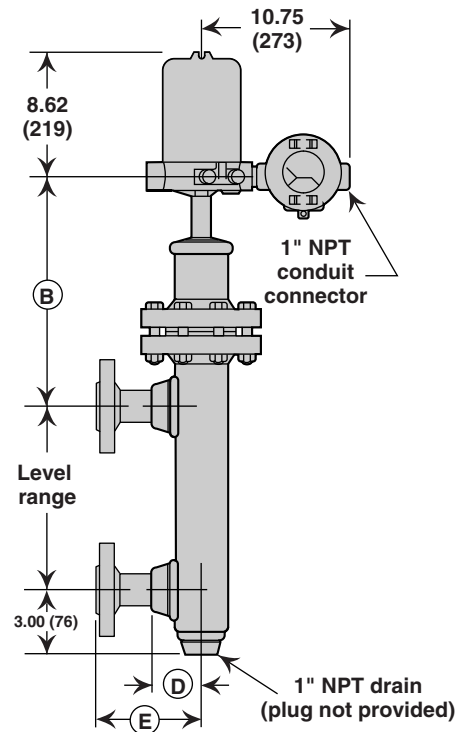
**Figure 29**  
HT Integral Side/Bottom Mount  
Fourth Digit Codes 7, 8, 9

Range Spring Specific Gravity Rating	A	B	C
.11 to .54	14.06 (357)	19.06 (484)	23.25 (591)
.55 to 1.09	12.12 (308)	17.12 (435)	21.31 (541)
1.10 to 2.20			

Outlet Size	D	E
1½"	3.19 (81)	6.25 (159)
2"	3.31 (84)	6.25 (159)

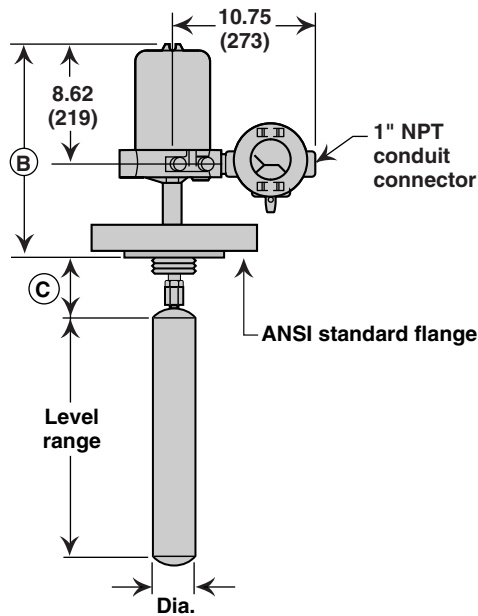


**Figure 30**  
Integral Top Mount



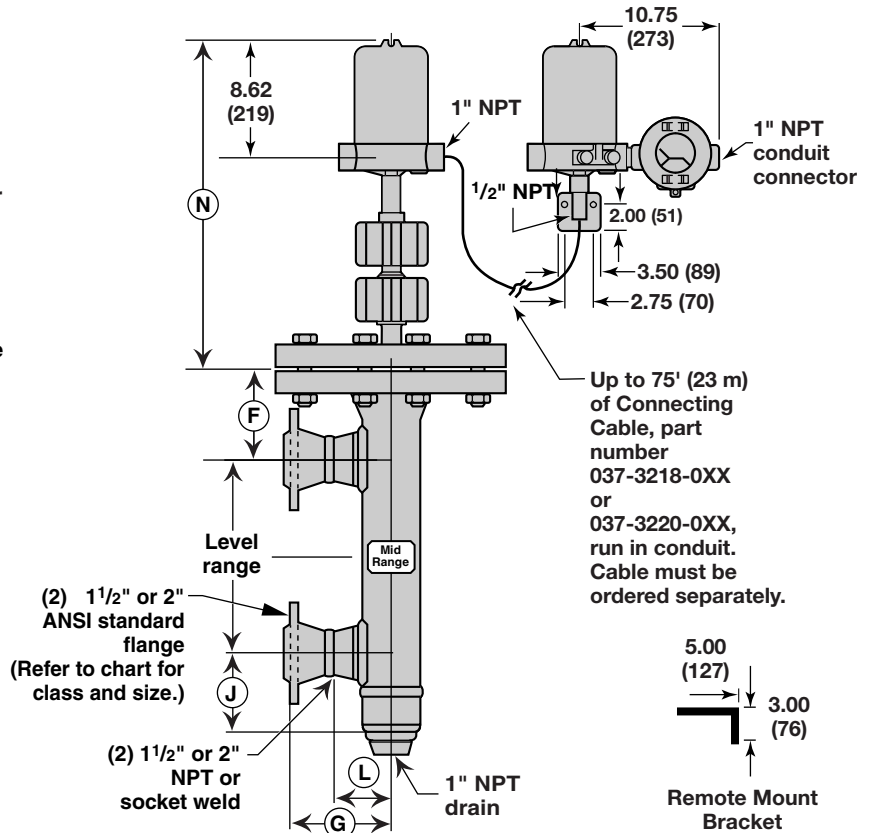
**Figure 31**  
Integral Side/Side Mount  
Fourth Digit Codes 1, 2, 3

**Dimensional specifications for high pressure models E51, E53, E55**



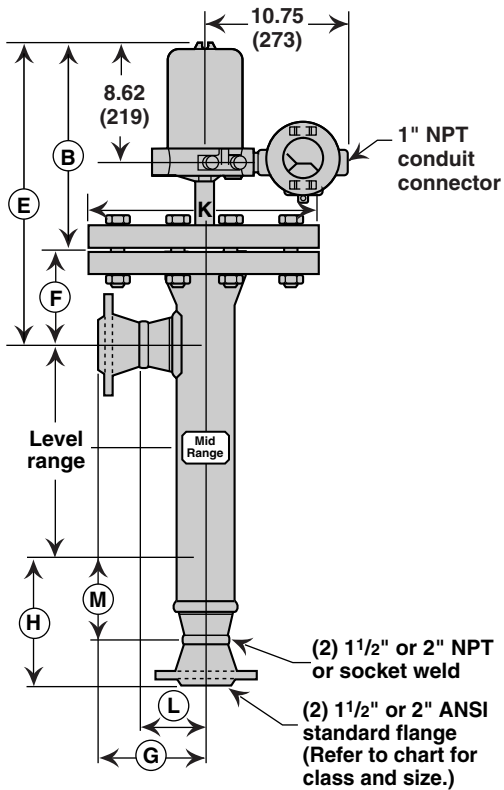
**Figure 32**

**E51 Series with Integral Top Mounting  
900, 1500, 2500 lb. Class**



**Figure 33**

**E55 Series with Side/Side Connections, Remote Mount  
900, 1500, 2500 lb. Class**



**Figure 34**

**E53 Series with Upper Side/Bottom Connections, Integral Mount  
900, 1500, 2500 lb. Class**

Flange Size & Class	Dimensions								
	B	C	E	F	G	H	J	K	N
1 1/2" - 900 lb.	16.38	9.31	25.81	9.31	7.25	8.43	3.44	11.50	20.57
	(416)	(236)	(655)	(236)	(184)	(214)	(87)	(292)	(522)
2" - 900 lb.					8.18	9.38			
					(208)	(238)			
1 1/2" - 1500 lb.	16.75	9.31	26.19	9.31	7.93	9.13	3.44	12.25	20.94
	(425)	(236)	(665)	(236)	(201)	(232)	(87)	(311)	(532)
2" - 1500 lb.					8.87	10.13			
					(225)	(257)			
1 1/2" - 2500 lb.	17.62	9.31	27.06	9.31	9.06	10.25	3.44	14.00	21.81
	(447)	(236)	(687)	(236)	(230)	(267)	(87)	(356)	(554)
2" - 2500 lb.					9.87	11.13			
					(251)	(283)			

Outlet Size	Dimensions	
	L	M
1 1/2" NPT or Socket Weld	4.00 (102)	3.44 (87)
2" NPT or Socket Weld	4.38 (111)	3.50 (89)

## 4.9 Model Numbers

### 4.9.1 Models for Steam applications (max. 600 lbs.)

#### DESIGN TYPE

E 6	Standard design EZ Modulelevel
-----	--------------------------------

#### MOUNTING AND CHAMBER MATERIALS

flanged top <sup>①</sup>		cage side/bottom		cage side/side		tank connection
steel	316 SS	steel	316 SS	steel	316 SS	chamber material
1	2	3	4	5	6	code

<sup>①</sup> Adjustable 8' hanger cable (p/n 32-3110-001), required when distance from flange face to top of displacer must be greater than 5.00"

#### SPECIFIC GRAVITY AND PROCESS TEMPERATURE

integral	remote	HT integral or remote	transmitter mounting
+300° F (+150° C)	+400° F (+200° C)	+500° F (+260° C)	maximum temperature
1	7	7	0.11 - 0.54 specific gravity <sup>②</sup>
2	8	8	0.55 - 1.09 specific gravity
3	9	9	1.10 - 2.20 specific gravity

<sup>②</sup> Consult factory for lower specific gravity design

#### TANK CONNECTION

##### Top mounted connection type

ANSI HEAD Flange rating			
RF 150 lbs	RF 300 lbs	RF 600 lbs	Size
G3	G4	G5	3"
H3	H4	H5	4"
K3	K4	K5	6"

##### External cage models

ANSI Cage rating			
RF 150 lbs	RF 300 lbs	RF 600 lbs	Size / Type
C5	C7	C9	1½" NPT
C6	C8	C0	1½" S.W.
P3	P4	P5	1½" flanged
D5	D7	D9	2" NPT
D6	D8	D0	2" S.W.
Q3	Q4	Q5	2" flanged

#### LEVEL RANGE

14	32	48	60	72	84	96	108	120	inches
356	813	1219	1524	1829	2134	2438	2743	3048	mm
A	B	C	D	E	F	G	H	I	code

TRANSMITTER - ELECTRONICS (see opposite page)

E 6

\_\_\_\_\_

complete order code for Standard EZ Modulelevel transmitter

**TRANSMITTER TYPE & MOUNTING**

E	Electronic Integral Mount
G	Electronic Remote Mount
R	Electronic High-temp Integral Mount

**TRANSMITTER OUTPUT**

Z	4-20 mA only (Analog)	24 VDC, 120 VAC or 240 VAC
S	4-20 mA with HART (Digital) <sup>①</sup>	24 VDC only

① HART communicator sold separately

**TRANSMITTER CONFIGURATION AND ACCESSORIES**

	Code	Display	Input Voltage	Agency Approval
Integral Mount  Fourth Digits 1, 2, 3 only  Eighth Digit E only  +300° F max.	A	None	24 VDC	EP – FM, CSA, CENELEC
	B	None	120 VAC <sup>②</sup>	EP – FM, CSA
	C	None	240 VAC <sup>②</sup>	EP – FM, CSA
	D	None	24 VDC	IS/NI – FM, CSA, CENELEC
	G	Analog	24 VDC	EP – FM, CSA, CENELEC
	I	Analog	24 VDC	IS/NI – FM, CSA, CENELEC
	L	Analog	120 VAC <sup>②</sup>	EP – FM, CSA
	N	Analog	240 VAC <sup>②</sup>	EP – FM, CSA
	J	Digital <sup>③</sup>	24 VDC	IS/NI – FM, CSA
Remote Mount  Fourth Digits 7, 8, 9 only  Eighth Digit G only  +400° F max.	9	Digital <sup>③</sup>	24 VDC	EP – FM, CSA, CENELEC
	H	None	24 VDC	EP – FM, CSA
	2	None	120 VAC <sup>②</sup>	EP – FM, CSA
	3	None	240 VAC <sup>②</sup>	EP – FM, CSA
	K	Analog	24 VDC	EP – FM, CSA
	5	Analog	120 VAC <sup>②</sup>	EP – FM, CSA
HT-Integral Mount  Fourth Digits 7, 8, 9 only  Eighth Digit R only  +500° F max.	6	Analog	240 VAC <sup>②</sup>	EP – FM, CSA
	7	Digital <sup>③</sup>	24 VDC	EP – FM, CSA
	Q	None	24 VDC	IS/NI – FM, CSA, CENELEC
	W	None	24 VDC	EP – FM, CSA, CENELEC
	T	Analog	24 VDC	IS/NI – FM, CSA, CENELEC
Remote Mount  Fourth Digits 7, 8, 9 only  Eighth Digit G only  +500° F max.	X	Analog	24 VDC	EP – FM, CSA, CENELEC
	4	Digital <sup>③</sup>	24 VDC	EP – FM, CSA, CENELEC
	Z	Digital <sup>③</sup>	24 VDC	IS/NI – FM, CSA
	Q	None	24 VDC	EP – FM, CSA
	R	None	120 VAC <sup>②</sup>	EP – FM, CSA
	S	None	240 VAC <sup>②</sup>	EP – FM, CSA
	T	Analog	24 VDC	EP – FM, CSA
Eighth Digit G only  +500° F max.	U	Analog	120 VAC <sup>②</sup>	EP – FM, CSA
	V	Analog	240 VAC <sup>②</sup>	EP – FM, CSA
	4	Digital	24 VDC	EP – FM, CSA

② 120 & 240 VAC available on Analog unit only (ninth digit Z)

③ Digital meter available on Digital Hart compatible unit only (ninth digit S)

**REMOTE CONNECTING CABLE**

Up to +400° F, specify cable 037-3218-0XX, where last two digits are cable length in feet from 1-75 feet.

Up to +500° F, specify cable 037-3220-0XX, where last two digits are cable length in feet from 1-75 feet.

□ □ □ Last 3 Digits of Model Number

## 4.9.2 Models for Steam applications (900 to 2500 lbs.)

### DESIGN TYPE

E 5	Standard design EZ Modulelevel
-----	--------------------------------

### MOUNTING AND CHAMBER MATERIALS

flanged top ①	cage side/bottom	cage side/side	tank connection with steel chamber material
1	3	5	code

① Adjustable 8' hanger cable (p/n 32-3110-001), required when distance from flange face to top of displacer must be greater than 9.31"

### SPECIFIC GRAVITY AND PROCESS TEMPERATURE

integral	remote	HT integral or remote	transmitter mounting
+300° F (+150° C)	+400° F (+200° C)	+500° F (+260° C)	maximum temperature
2	8	8	0.55 - 1.09 specific gravity

### TANK CONNECTION

#### Top mounted connection type

ANSI HEAD Flange rating			
RF 900 lbs	RF 1500 lbs	RF 2500 lbs	Size
H6	H7	H8	4"
K6	K7	K8	6"

#### External cage models

ANSI Cage rating			
RF 900 lbs	RF 1500 lbs	RF 2500 lbs	Size / Type
L5	L7	L9	1½" NPT
M5	M7	M9	1½" S.W.
P6	P7	P8	1½" flanged
L6	L8	L0	2" NPT
M6	M8	M0	2" S.W.
Q6	Q7	Q8	2" flanged

### LEVEL RANGE

14	32	48	60	inches
356	813	1219	1524	mm
A	B	C	D	code

TRANSMITTER – ELECTRONICS (see opposite page)

E	5						
---	---	--	--	--	--	--	--

complete order code for Standard EZ Modulelevel transmitter

**TRANSMITTER TYPE & MOUNTING**

E	Electronic Integral Mount
G	Electronic Remote Mount
R	Electronic High-temp Integral Mount

**TRANSMITTER OUTPUT**

Z	4-20 mA only (Analog)	24 VDC, 120 VAC or 240 VAC
S	4-20 mA with HART (Digital) <sup>①</sup>	24 VDC only

① HART communicator sold separately

**TRANSMITTER CONFIGURATION AND ACCESSORIES**

	Code	Display	Input Voltage	Agency Approval
<b>Integral Mount</b>	A	None	24 VDC	EP – FM, CSA, CENELEC
	B	None	120 VAC <sup>②</sup>	EP – FM, CSA
	C	None	240 VAC <sup>②</sup>	EP – FM, CSA
	D	None	24 VDC	IS/NI – FM, CSA, CENELEC
Fourth Digit 2 only	G	Analog	24 VDC	EP – FM, CSA, CENELEC
Eighth Digit E only	I	Analog	24 VDC	IS/NI – FM, CSA, CENELEC
	L	Analog	120 VAC <sup>②</sup>	EP – FM, CSA
+300° F max.	N	Analog	240 VAC <sup>②</sup>	EP – FM, CSA
	J	Digital <sup>③</sup>	24 VDC	IS/NI – FM, CSA
	9	Digital <sup>③</sup>	24 VDC	EP – FM, CSA, CENELEC
<b>Remote Mount</b>	H	None	24 VDC	EP – FM, CSA
	2	None	120 VAC <sup>②</sup>	EP – FM, CSA
Fourth Digit 8 only	3	None	240 VAC <sup>②</sup>	EP – FM, CSA
Eighth Digit G only	K	Analog	24 VDC	EP – FM, CSA
	5	Analog	120 VAC <sup>②</sup>	EP – FM, CSA
+400° F max.	6	Analog	240 VAC <sup>②</sup>	EP – FM, CSA
	7	Digital <sup>③</sup>	24 VDC	EP – FM, CSA
<b>HT-Integral Mount</b>	Q	None	24 VDC	IS/NI – FM, CSA, CENELEC
	W	None	24 VDC	EP – FM, CSA, CENELEC
Fourth Digit 8 only	T	Analog	24 VDC	IS/NI – FM, CSA, CENELEC
Eighth Digit R only	X	Analog	24 VDC	EP – FM, CSA, CENELEC
	4	Digital <sup>③</sup>	24 VDC	EP – FM, CSA, CENELEC
+500° F max.	Z	Digital <sup>③</sup>	24 VDC	IS/NI – FM, CSA
	Q	None	24 VDC	EP – FM, CSA
<b>Remote Mount</b>	R	None	120 VAC <sup>②</sup>	EP – FM, CSA
	S	None	240 VAC <sup>②</sup>	EP – FM, CSA
Fourth Digit 8 only	T	Analog	24 VDC	EP – FM, CSA
Eighth Digit G only	U	Analog	120 VAC <sup>②</sup>	EP – FM, CSA
	V	Analog	240 VAC <sup>②</sup>	EP – FM, CSA
+500° F max.	4	Digital	24 VDC	EP – FM, CSA

② 120 & 240 VAC available on Analog unit only (ninth digit Z)

③ Digital meter available on Digital Hart compatible unit only (ninth digit S)

**REMOTE CONNECTING CABLE**

Up to +400° F, specify cable 037-3218-0XX, where last two digits are cable length in feet from 1-75 feet.

Up to +500° F, specify cable 037-3220-0XX, where last two digits are cable length in feet from 1-75 feet.

□ □ □ Last 3 Digits of Model Number

### 4.9.3 Models for Non-Steam applications (max. 600 lbs.)

#### DESIGN TYPE

E 6	Standard design EZ Modulelevel
-----	--------------------------------

#### MOUNTING AND CHAMBER MATERIALS

flanged top <sup>①</sup>		cage side/bottom		cage side/side		tank connection
steel	316 SS	steel	316 SS	steel	316 SS	chamber material
1	2	3	4	5	6	code

<sup>①</sup> Adjustable 8' hanger cable (p/n 32-3110-001), required when distance from flange face to top of displacer must be greater than 5.00"

#### SPECIFIC GRAVITY AND PROCESS TEMPERATURE

integral	remote	HT integral or remote	transmitter mounting
+400° F (+200° C)	+500° F (+290° C)	+600° F (+315° C)	maximum temperature
1	7	7	0.23 - 0.54 specific gravity <sup>②</sup>
2	8	8	0.55 - 1.09 specific gravity
3	9	9	1.10 - 2.20 specific gravity

<sup>②</sup> Consult factory for lower specific gravity design

#### TANK CONNECTION

##### Top mounted connection type

ANSI HEAD Flange rating			
RF 150 lbs	RF 300 lbs	RF 600 lbs	Size
G3	G4	G5	3"
H3	H4	H5	4"
K3	K4	K5	6"

##### External cage models

ANSI Cage rating			
RF 150 lbs	RF 300 lbs	RF 600 lbs	Size / Type
C5	C7	C9	1½" NPT
C6	C8	C0	1½" S.W.
P3	P4	P5	1½" flanged
D5	D7	D9	2" NPT
D6	D8	D0	2" S.W.
Q3	Q4	Q5	2" flanged

#### LEVEL RANGE

14	32	48	60	72	84	96	108	120	inches
356	813	1219	1524	1829	2134	2438	2743	3048	mm
A	B	C	D	E	F	G	H	I	code

TRANSMITTER – ELECTRONICS (see opposite page)



complete order code for Standard EZ Modulelevel transmitter

**TRANSMITTER TYPE & MOUNTING**

E	Electronic Integral Mount
G	Electronic Remote Mount
R	Electronic High-temp Integral Mount

**TRANSMITTER OUTPUT**

Z	4-20 mA only (Analog)	24 VDC, 120 VAC or 240 VAC
S	4-20 mA with HART (Digital) <sup>①</sup>	24 VDC only

① HART communicator sold separately

**TRANSMITTER CONFIGURATION AND ACCESSORIES**

	Code	Display	Input Voltage	Agency Approval
Integral Mount  Fourth Digits 1, 2, 3 only  Eighth Digit E only  +400° F max.	A	None	24 VDC	EP – FM, CSA, ATEX <sup>④</sup>
	B	None	120 VAC <sup>②</sup>	EP – FM, CSA
	C	None	240 VAC <sup>②</sup>	EP – FM, CSA
	D	None	24 VDC	IS/NI – FM, CSA, ATEX
	G	Analog	24 VDC	EP – FM, CSA, ATEX <sup>④</sup>
	I	Analog	24 VDC	IS/NI – FM, CSA, ATEX
	L	Analog	120 VAC <sup>②</sup>	EP – FM, CSA
	N	Analog	240 VAC <sup>②</sup>	EP – FM, CSA
	J	Digital <sup>③</sup>	24 VDC	IS/NI – FM, CSA
Remote Mount  Fourth Digits 7, 8, 9 only  Eighth Digit G only  +500° F max.	9	Digital <sup>③</sup>	24 VDC	EP – FM, CSA, ATEX <sup>④</sup>
	H	None	24 VDC	EP – FM, CSA
	2	None	120 VAC <sup>②</sup>	EP – FM, CSA
	3	None	240 VAC <sup>②</sup>	EP – FM, CSA
	K	Analog	24 VDC	EP – FM, CSA
	5	Analog	120 VAC <sup>②</sup>	EP – FM, CSA
HT-Integral Mount  Fourth Digits 7, 8, 9 only  Eighth Digit R only  +600° F max.	6	Analog	240 VAC <sup>②</sup>	EP – FM, CSA
	7	Digital <sup>③</sup>	24 VDC	EP – FM, CSA
	Q	None	24 VDC	IS/NI – FM, CSA, ATEX
	W	None	24 VDC	EP – FM, CSA, ATEX <sup>④</sup>
	T	Analog	24 VDC	IS/NI – FM, CSA, ATEX
	X	Analog	24 VDC	EP – FM, CSA, ATEX <sup>④</sup>
Remote Mount  Fourth Digits 7, 8, 9 only  Eighth Digit G only  +600° F max.	4	Digital <sup>③</sup>	24 VDC	EP – FM, CSA, ATEX <sup>④</sup>
	Z	Digital <sup>③</sup>	24 VDC	IS/NI – FM, CSA
	Q	None	24 VDC	EP – FM, CSA
	R	None	120 VAC <sup>②</sup>	EP – FM, CSA
	S	None	240 VAC <sup>②</sup>	EP – FM, CSA
	T	Analog	24 VDC	EP – FM, CSA
	U	Analog	120 VAC <sup>②</sup>	EP – FM, CSA
	V	Analog	240 VAC <sup>②</sup>	EP – FM, CSA
	4	Digital	24 VDC	EP – FM, CSA

② 120 & 240 VAC available on Analog unit only (ninth digit Z)

③ Digital meter available on Digital Hart compatible unit only (ninth digit S)

④ ATEX EP approval requires modification of unit. Model must be “X’d” for a heavy-wall e-tube.

**REMOTE CONNECTING CABLE**

Up to +500° F, specify cable 037-3218-0XX, where last two digits are cable length in feet from 1-75 feet.

Up to +600° F, specify cable 037-3220-0XX, where last two digits are cable length in feet from 1-75 feet.

□ □ □ Last 3 Digits of Model Number

### Service Policy

Owners of Magnetrol/STI controls may request the return of a control or any part of a control for complete rebuilding or replacement. They will be rebuilt or replaced promptly. Controls returned under our service policy must be returned by Prepaid transportation. Magnetrol/STI will repair or replace the control at no cost to the purchaser (or owner) other than transportation if:

1. Returned within the warranty period; and
2. The factory inspection finds the cause of the claim to be covered under the warranty.

If the trouble is the result of conditions beyond our control; or, is NOT covered by the warranty, there will be charges for labor and the parts required to rebuild or replace the equipment.

In some cases it may be expedient to ship replacement parts; or, in extreme cases a complete new control, to replace the original equipment before it is returned. If this is desired, notify the factory of both the model and serial numbers of the control to be replaced. In such cases, credit for the materials returned will be determined on the basis of the applicability of our warranty.

No claims for misapplication, labor, direct or consequential damage will be allowed.

### Return Material Procedure

So that we may efficiently process any materials that are returned, it is essential that a "Return Material Authorization" (RMA) number be obtained from the factory, prior to the material's return. This is available through Magnetrol/STI's local representative or by contacting the factory. Please supply the following information:

1. Company Name
2. Description of Material
3. Serial Number
4. Reason for Return
5. Application

Any unit that was used in a process must be properly cleaned in accordance with OSHA standards, before it is returned to the factory.

A Material Safety Data Sheet (MSDS) must accompany material that was used in any media.

All shipments returned to the factory must be by prepaid transportation.

All replacements will be shipped F.O.B. factory.

NOTE: See Electrostatic Discharge Handling Procedure on page 1.

NOTE: If unit needs to be returned, the displacer must be secured to prevent damage in transit.



5300 Belmont Road • Downers Grove, Illinois 60515-4499 • 630-969-4000 • Fax 630-969-9489 • www.magnetrol.com  
 145 Jardin Drive, Units 1 & 2 • Concord, Ontario Canada L4K 1X7 • 905-738-9600 • Fax 905-738-1306  
 Heikensstraat 6 • B 9240 Zele, Belgium • 052 45.11.11 • Fax 052 45.09.93  
 Regent Business Ctr., Jubilee Rd. • Burgess Hill, Sussex RH15 9TL U.K. • 01444-871313 • Fax 01444-871317



5300 Belmont Road • Downers Grove, Illinois 60515-4499 • 630-969-4028 • Fax 630-969-9489 • www.sticontrols.com