



E3 Modulelevel® Retrofits



- E3 Transmitter Head Onto Existing Electronic Modulelevel
- E3A or E3B Head Into Existing Modulelevel Chamber
- E3A or E3B Head Into Existing Torque Tube Transmitter Chamber

The new E3 electronic Modulelevel incorporates many advances not previously available in a displacer transmitter. This exciting product offers communications via a variety of platforms; three-button keypad and two-line × eight-character LCD display, HART® communications, AMS, PACTware or FOUNDATION fieldbus™. The use of the distinctive Eclipse® dual-compartment angled housing results in a sleek, modernized look, as well as, decreased size and weight.

The E3 Modulelevel is ideal for retrofitting onto an existing Modulelevel or into an existing Modulelevel or other manufacturer's chamber.

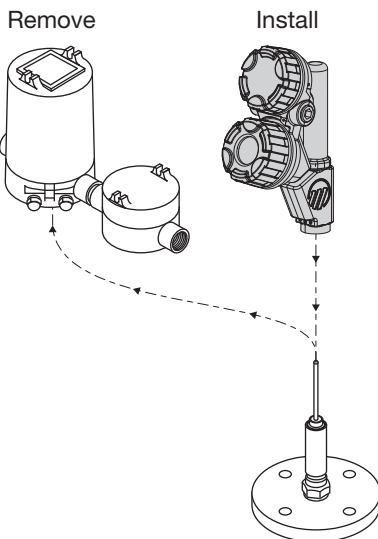

E3 Transmitter Head Onto Existing Electronic Modulelevel

The E3 transmitter head can be retrofitted onto all existing EZ, Smart EZ, ES II and E3 sensing units. Order part number Z39-4101-Hxx, where the ninth and tenth digits are identical to those of the applicable E3 model number (see bulletin 48-135).

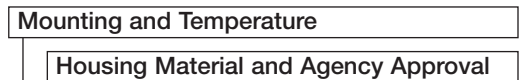

Z39-4101-H

Remove the old transmitter head and install the new head on the existing enclosing tube (see bulletin 48-697). User calibration must be performed with E3 head on old sensing unit.

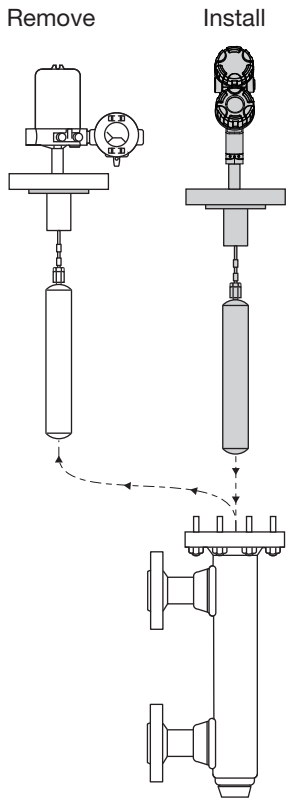

E3A or E3B Head Into Existing Modulelevel Chamber

A top mounted E3 Modulelevel can be mounted into an existing pneumatic or electronic Modulelevel chamber. A standard model E3 can be dropped into an existing blind flange design chamber (P5x, E5x). If the existing Modulelevel has a top-hat style chamber, a specially modified E3 can be mounted into the existing top hat design chamber (P6x, E6x).

Order model E3A or E3B for existing blind chamber, or an XE3A or XE3B, X=special stem length for an existing top-hat chamber. Remove old Modulelevel displacer and top works from chamber and mount the new E3 as you would any top mounted model (see bulletin 48-635). Simple configuration must be performed (no calibration required).

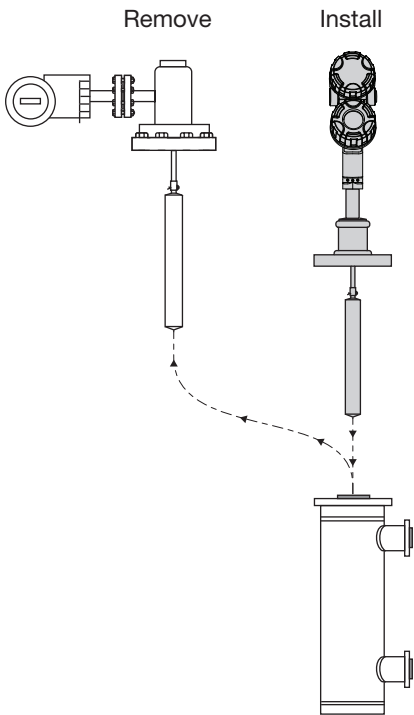

E3A or E3B Head Into Existing Torque Tube Transmitter Chamber

A top mounted E3 Modulelevel can be mounted into an existing side/side or side/bottom configuration torque tube chamber.* The unit must be specially modified with a compatible head flange and stem length adjusted for the torque tube chamber.

Order model XE3A or XE3B, X=torque-tube flange, special stem length. Remove the old torque tube top works and displacer from the chamber and mount the new E3 as you would any top mounted model (see bulletin 48-635). Simple configuration must be performed (no calibration required).

Proprietary Flanges

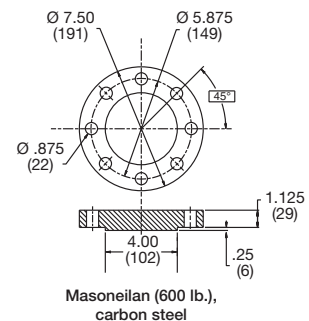
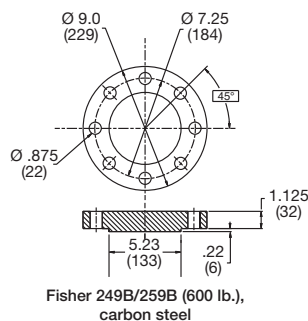

* E3 cannot be retrofit onto a Fisher 249C chamber.

