



Magnetrol®
STI



Echotel® Model 911 & 921 Ultrasonic Level Controls

Instruction Manual and Parts List

DESCRIPTION

Echotel Model 911/921 units ultrasonically detect liquid level on a broad spectrum of viscous to light liquids. There are no moving parts in contact with the liquid. Model 911/921 units are available with either integral or remote mounted electronics.



MODEL IDENTIFICATION

Each control has a nameplate on which the model number is shown. The model number is coded to identify the options included in that specific unit. Listed below are the definitions of each section of the model number. By comparing the model number against these charts, the installer can determine exactly which options the unit contains.

AMPLIFIER

9 1 - - 1

Set Points

- 1 = 1 set point
- 2 = 2 set points

Output Signal

- A1A = 10 amp DPDT relay
- B1C = 5 amp DPDT hermetic relay
- E1H = TTL
- F1H = open collector

Input Voltage

- 0 = 120 VAC
- 1 = 240 VAC
- 2 = 24 VDC
- 3 = 12 VDC

Housing

- A = NEMA 4X, Carbon steel
- E = NEMA 4X/7/9, Cast aluminum, Model 911 only
- F = NEMA 4X/7/9, Cast iron, Model 921 only
- H = NEMA 4X/7/9 Group B, Cast iron
- I = GENELEC

Mounting

- 0 = Integral
- 1 = Remote

MODEL IDENTIFICATION cont.

TRANSDUCER

5 8 - 1 A -

Set Points

- 1 = 1 set point
- 2 = 2 set points

Connection

- 1A = 3/4" NPT

Transducer Material

- 22 = 316 Stainless Steel
 - CC = CPVC
 - E1 = Epoxy, Model 911 only
 - FF = Teflon® max. 48" insertion, Model 911 only
 - HB = Hastelloy B
 - HC = Hastelloy C
 - KK = Kynar, Model 911 only
 - MM = Monel
 - TT = Titanium
 - YY = Polypropylene
- Teflon® is a registered trademark of DuPont.

Actuation Length

1 to 130 inches in one inch increments (25 mm to 3.3 m)
(Nominal distance from bottom of threads to top of gap in inches).

Example: 12 inches = Code 012

COAXIAL CABLE

3 7 0 - 1 1 -

Remote Housing with Self-Test

Cable Type

- A1 = RG 178 cable, Model 911
- A2 = RG 178 cable, Model 921
- B1 = RG 58 cable, Model 911
- B1 = RG 58 cable, Model 921

Cable Length

Length of cable from remote amplifier to remote transducer in feet (300 ft. [90 m] maximum)
RG 178 cable, 1-50 ft. [15 m] maximum
RG 58 cable, 51-300 ft. [90 m] maximum

PRINCIPLE OF OPERATION

Ultrasonic sound waves are transmitted through the transducer gap when it is filled with liquid, thus actuating the control. As the liquid drains from the gap, the sound waves attenuate, deactuating the control. A signal processing circuit ensures that the system will not produce false indication due to splashing or light turbulence.

ELECTROSTATIC DISCHARGE (ESD) HANDLING PROCEDURE

Magnetrol's electronic instruments are manufactured to the highest quality standards. These instruments utilize electronic components which may be damaged by static electricity present in most work environments. The following steps are recommended to reduce the risk of component failure due to electrostatic discharge:

1. Ship and store circuit boards in anti-static bags. If an anti-static bag is not available, wrap board in aluminum foil. Do not place boards on foam packing materials.

2. Use a grounding wrist strap when installing and removing circuit boards. A grounded workstation is also recommended.
3. Handle printed circuit boards only by the edges. Do not touch components or connector pins.
4. Ensure that all electrical connections are completely made and none are partial or floating. Ground all equipment to a good, earth ground.

INSTALLATION

UNPACKING

Unpack the instrument carefully. Make sure all components have been removed from the foam protection. Inspect all components for damage. Report any concealed damage to the carrier within 24 hours. Check the contents of the package against the packing slip and report any discrepancies to the factory. Check the nameplate model number to be sure it agrees with the packing slip and purchase order. Check and record the serial number for future reference when ordering parts.

PRELIMINARY OPERATIONAL CHECK

1. Apply proper operating voltage to terminals L1, L2/N. Connect the ground wire to the green ground screw inside the housing base. Refer to Figure 4 on page 3.
2. With the power applied to the board, locate the HL/LL fail-safe switch marked P1 on the right hand side of the board. Place the jumper in the desired HL or LL fail-safe position. Refer to the table on page 5.

CAUTION: Phono jack plugs are fragile. Do not pull plugs from PC board by pulling coaxial cable. Use needle nose pliers on plug body.

3. Fill a suitable container with liquid.
4. Place transducer gap in the liquid. The control output(s) must actuate.
4. Remove transducer from the liquid. The control output(s) must deactuate if the unit is operating properly. In case of malfunction consult the Troubleshooting section on page 7.

MOUNTING POSITION AND LOCATION

Single point units may be mounted in any position or orientation. Refer to Figures 1 and 2. Dual point units must be mounted with the transducer vertical. Refer to Figure 1.

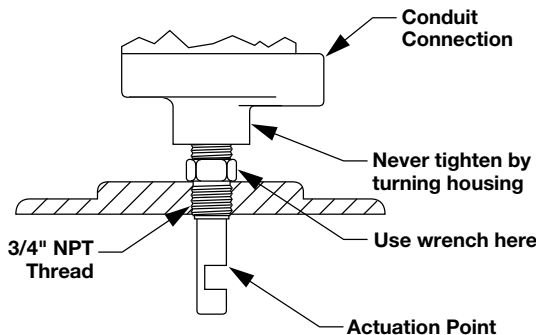

Vertical Mounting for Single or Dual Gap Units
Figure 1

MOUNTING POSITION AND LOCATION cont.

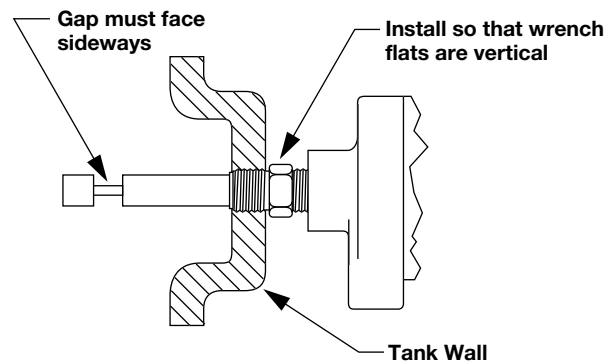

Horizontal Mounting for Single Gap Units Only
Figure 2

When installed in a nozzle or pipe, the transducer gap must extend into the tank beyond the inside tank wall. Refer to Figure 3.

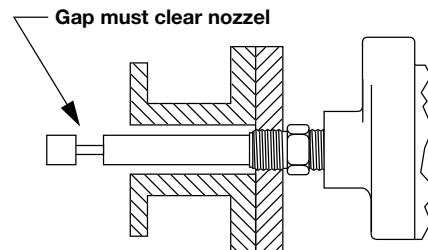

Horizontal Mounting in Nozzle
Figure 3

All wiring, conduit and electrical fittings must conform to local electrical codes for the location selected.

INSTALLATION cont.

INTEGRAL INSTALLATION

1. Screw transducer into the opening using pipe compound or thread tape. If flanged, bolt unit to mating flange with proper gasket.

CAUTION: Never tighten unit to the tank connection by turning the housing. Use a wrench on the transducer mounting nut flats. Use thread tape or suitable pipe compound on threads. Do not over tighten.

2. Remove housing cover.
3. No. 14 AWG wire size is recommended for power and control circuit wiring. The power and control circuit terminal blocks are marked for proper identification.
 - a. Route wires into housing.
 - b. Run power leads to power terminal on left side of PC board. Refer to Figure 4.
 - c. Attach ground wire to the green head screw located in the housing base.
 - d. Run control circuit wiring to the top of PC board.
 - e. Dress wiring to ensure no interference or contact with cover or circuit board components.

NOTE: For Model 921 duplicate these steps for second board.

OBSERVE ALL APPLICABLE ELECTRICAL CODES AND PROPER WIRING PROCEDURES.

Prevent moisture seepage into the enclosure by installing approved seal-drain fittings in the conduit run leading to the unit.

INTEGRAL INSTALLATION CONT.

4. If the transducer phono cables become unplugged from the circuit board, they must be reconnected in the following order:

CAUTION: Phono jack plugs are fragile. Do not pull plugs from PC board by pulling coaxial cable. Use needle nose pliers on plug body.

Model 911 cables may plug into J1 and J2 on the amplifier board in any order.

Model 921 cables are banded together in pairs. One cable from each pair is tagged either HIGH or LOW. One pair plugs into one board; the second pair plugs into the second board. The boards are labeled HIGH or LOW.

CAUTION: In hazardous areas, do not power the unit until the conduit is sealed and enclosure cover is screwed down securely.

NOTE: The tagged cable from each pair must plug into J2 on its respective board. Failure to do so will impair the operation of the unit.

5. Replace housing cover.

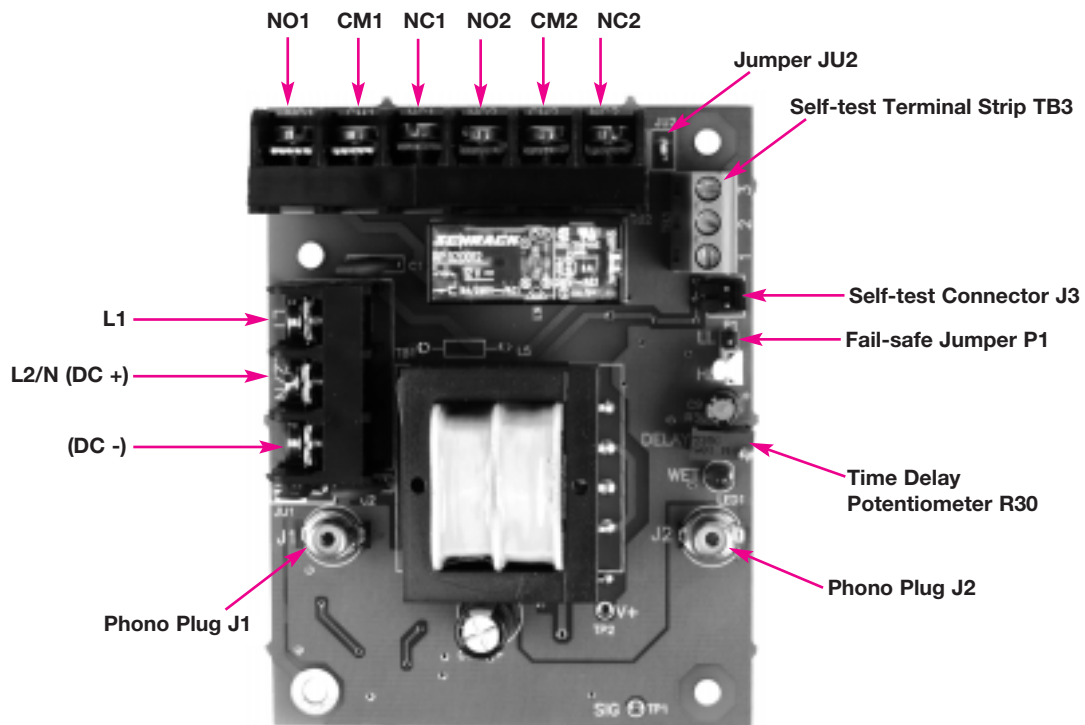

**Main Amplifier Board
Figure 4**

INSTALLATION cont.

REMOTE AMPLIFIER INSTALLATION

Remote amplifiers must be used where high process temperatures prohibit integral mounting of the electronics. A remote amplifier allows more convenient servicing when the transducer is mounted at an inconvenient location.

1. Install amplifier housing using mounting bracket. Provide adequate clearance to remove housing cover.
2. Remove housing cover.

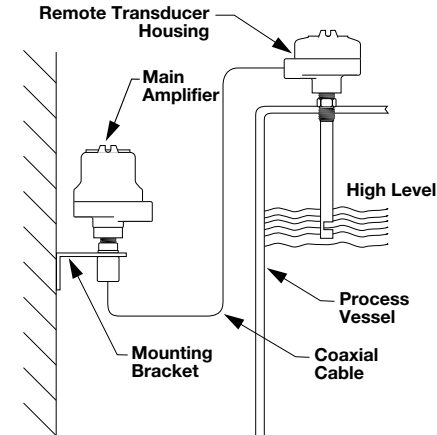

Figure 5

3. No. 14 AWG wire size is recommended for power and control circuit wiring. The power and control terminal blocks are marked for proper identification.
 - a. Route power and control circuit through side housing connection.
 - b. Run power leads to power terminal on left side of PC board. Refer to Figure 4 on page 3.
 - c. Run control circuit leads to top of PC board.
 - d. Run coaxial cable from transducer or remote transducer termination board through the bottom housing connection.
 - e. Plug coaxial cable to amplifier as follows:

Model 911 cables from OUT 1 and OUT 2 on remote transducer board plug into J1 and J2 on the amplifier board in any order. The self test cable plugs into J2 on remote transducer board and J3 on the amplifier board.

Model 921 cables from OUT 1 and OUT 2 on the remote transducer board plug into the lower amplifier board; cables from OUT 3 and OUT 4 plug into the upper amplifier board. One self test cable plugs into J2 on the remote transducer board and goes to J3 on the lower amplifier board. The other self test cable plugs into J4 on the remote transducer board and goes to J3 on the upper amplifier board.

NOTE: Cables from OUT 2 and OUT 4 must plug into J2 on their respective board. Failure to do so will impair the operation of the unit.

- f. Dress wiring to ensure no interference or contact with cover or circuit board components.

CAUTION: Do not interchange transducer connection cables (OUT 1 and OUT 2 with OUT 3 and OUT 4) or remote connection cable (OUT 1 and OUT 2 with OUT 3 and OUT 4) or the unit will malfunction.

REMOTE AMPLIFIER INSTALLATION cont.

Prevent moisture seepage into the enclosure by installing approved seal-drain fittings in the conduit run leading into the unit.

CAUTION: In hazardous areas, do not power the unit until the conduit is sealed and the enclosure cover is screwed down securely.

4. Replace housing cover.

REMOTE TRANSDUCER INSTALLATION

1. Screw transducer into tank opening using pipe compound or thread tape. If flanged, bolt unit to mating flange with proper gasket.

NOTE: Refer to Coaxial Cable Installation section below before installing cables.

2. To prevent cable damage, DO NOT remove transducer from tank with coaxial cable connected to the amplifier.

CAUTION: Never tighten transducer to tank connection by turning housing. Use wrench on transducer mounting nut flats. Use thread tape or suitable pipe compound on threads. Do not over tighten.

COAXIAL CABLE INSTALLATION

Transducers are furnished with dual coaxial cables. If unit purchased is not equipped with remote transducer housing, coaxial cable must be run in conduit to the amplifier.

If a remote transducer housing is furnished, the coaxial cables from the transducer will terminate inside the housing in phono jacks marked IN1 and IN2. Model 921 units will have an additional pair of cables terminating in IN3 and IN4. Connect coaxial cable to jacks OUT 1 and OUT 2 on remote transducer termination board. If installing a Model 921, connect the second pair of cables to jacks 03 and 04. (Coaxial cable extensions must be run in conduit.) Refer to Figure 6 on page 5.

CAUTION: To retain explosion proof/vapor proof rating, coaxial cable must be run in properly sealed conduit.

OBSERVE ALL APPLICABLE ELECTRICAL CODES AND PROPER WIRING PROCEDURES.

USER SELECTIONS

RELAY WIRING

Model 911 units have a number of different relay wiring options. The table below lists relay contact positions for all possible combinations of power failure, state of the transducer gap and fail-safe jumper position. Each user must decide, from consideration of the overall system, which combinations of the above constitutes fail-safe and alarm conditions; and, select the appropriate relay wiring and fail-safe positions.

For Model 921 units, the table can be used for selecting the mode of operation for one point at a time.

CONTROL RELAY WIRING CHART

Fail-safe Jumper Position	Line Power	Transducer Gap	Relay Terminals	
			CM to NC	CM to NO
Low Level Jumper P1 (LL)	On	Dry	Closed	Open
		Wet	Open	Closed
	Failure	Dry	Closed	Open
		Wet	Closed	Open
High Level Jumper P1 (HL)	On	Dry	Open	Closed
		Wet	Closed	Open
	Failure	Dry	Closed	Open
		Wet	Closed	Open

NOTE: Care should be exercised not to interchange wires between Pole 1 and Pole 2 termination connections.

FAIL-SAFE JUMPER

Model 911/921 are available with a field selectable fail-safe jumper (P1) for low or high level. The jumper is located above potentiometer (R30) located along the right edge of each printed circuit board. Refer to Figure 7. In this instance, the term fail-safe denotes the positions the relay contacts assume when power to the unit is lost.

CALIBRATION

Model 911/921 units do not require field calibration. The set point is not adjustable.

TIME DELAY

Model 911/921 units are provided with an adjustable turn-on delay of up to approximately 60 seconds. The time delay occurs when the transducer gap goes from the "dry" to the "wet" state. Minimum time delay occurs with potentiometer (R30) adjusted fully counterclockwise (CCW). Increase time delay by turning clockwise (CW). Refer to Figure 7.

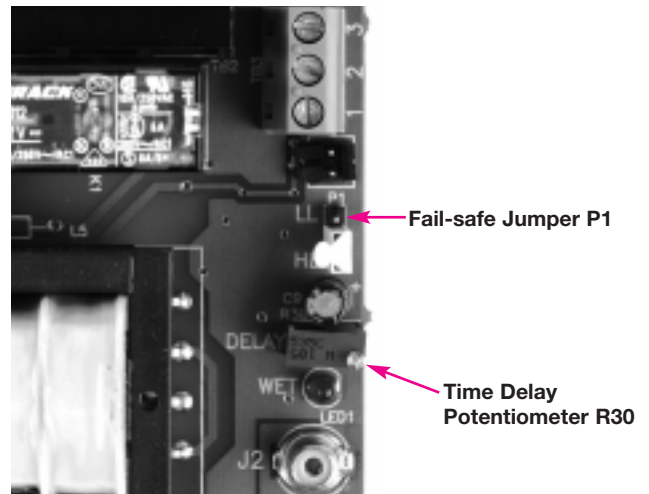

Main Amplifier Board
Figure 7

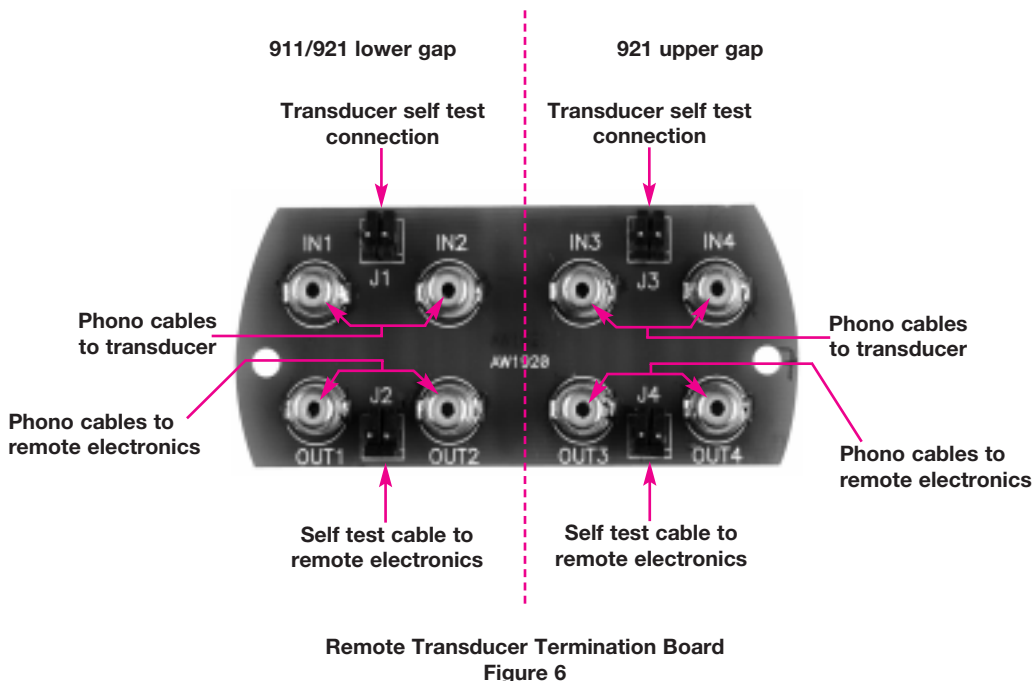

Remote Transducer Termination Board
Figure 6

USER SELECTIONS cont.

CIRCUITRY CHECK

Transducer dry

A complete test of the transducer and electronic circuitry may be made by using one of the following tests:

1. **Self test:** Locate the self test terminal strip (TB3) on the right side of the board. With a small jumper, momentarily touch terminals 1 and 2. The result should be the relay contacts changing state. Refer to Figure 8.
2. **Current meter:** Hook the meter in series: red or (+) lead to terminal 1, black or (-) lead to terminal 2. The result should be a measurement of the current going to the reed switch. Approximately 10 mA to 20 mA is the normal range of current. If current is not present, contact the factory.

NOTE: A current meter should be used to verify self test only if the relay does not change state with the jumper.

3. **Local magnetic check:** With power on, and all cable connections made, take a horseshoe magnet and place it at the mounting nut rotating it around the circumference. From the "dry" state when the proper orientation of the magnetic field is located to the reed switch, the relay will change state to simulate "wet" condition. Remove the magnet and the relay will return to the "dry" state. If this does not work a stronger magnet may be needed.

NOTE: For units with time delay, output activation occurs following selected time delay.

4. **Local push button, less than 30 feet away, (supplied by user) using unit power:** Wire a momentary contact switch to self test terminals 1 and 2 of TB3. Refer to Figure 8. This switch must have normally open contacts, and must be suitable for the atmosphere surrounding the control.

Depress the momentary contact switch. The control output must activate, simulating liquid in the gap. Release the momentary contact switch. The control output must deactivate. The LED will go out immediately.

CAUTION: Do not connect terminal 1 to any other terminal. Instrument damage will occur.

CIRCUITRY CHECK cont.

Transducer dry cont.

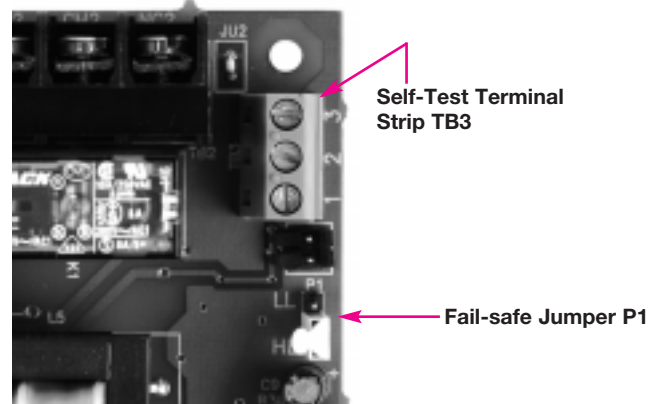

Figure 8

5. **Remote push button, more than 30 feet away, using external power:** Remove power to unit. Cut jumper wire JU2 in the top right corner of the board. Refer to Figure 9. Wire remote push button to terminals 2 and 3 of TB3, providing external power in the loop. (Requires a 12 VDC power supply.) Connect the positive (+) 12 VDC wire to terminal 2. Connect the negative (-) wire to terminal 3. Depress the push button—control output should activate, simulating liquid in the gap. LED will light immediately.

CAUTION: Do not connect terminal 3 to any other terminal. Instrument damage will occur.

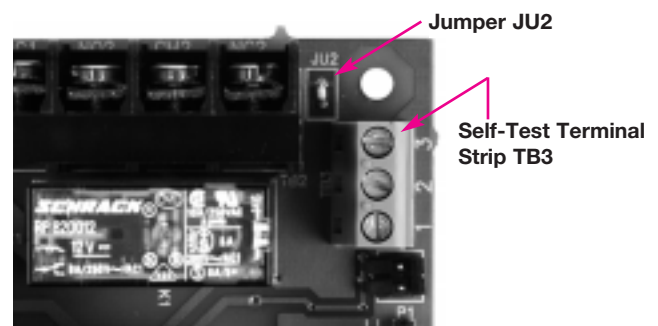

Figure 9

OPERATIONAL TEST (Integral or Remote Units)

With the transducer properly connected to the amplifier, check to ensure all cable connections are correct.

1. Fill a small vessel with water and completely immerse the bottom gap of the transducer. In this condition the transducer is now in the WET state. The relay should change state.
2. Remove the transducer from the vessel of water. In this condition the transducer is now in the DRY state. The relay should change state again.

If the relay changes state going from DRY to WET the equipment is functioning correctly.

NOTE: A balloon filled with water may be substituted for a small vessel of water. When using this method be sure the outside of the balloon surface is wet. Note the position of the relay in the DRY state. Now, take the wetted balloon and put it in the transducer gap. The result should be a change in the relay state. The unit is now in a WET condition.

In case of malfunction, consult the Troubleshooting section or consult factory.

TROUBLESHOOTING

CAUTION: In hazardous areas, do not remove housing until power is disconnected and atmosphere is determined to be safe.

No signal with level change

1. Verify power and control circuit wiring.
2. Check the red LED on the board. The LED will light immediately when the transducer gap is filled with liquid, or when a self test check is performed on the unit. The LED is not affected by the time delay. Refer to Figure 4 on page 3.
3. For integral units, check transducer phono plugs for proper insertion in J1 and J2. For remote units, check remote cable phono plugs in J1 and J2 and all phono plugs in remote transducer termination board.
4. With the transducer dry, test control circuit with magnet or push button. If control circuit activates, remove unit from vessel and check for foreign media in transducer gap.
5. If control circuit does not activate, consult factory.

Self-test circuitry works, but control relay does not activate on level change.

1. Check for plugged or fouled sensor gap.
2. Sensor gap faces not parallel.
3. Inspect unit for failed or dirty relay contacts.
4. If control does not activate, consult factory.

Sensor wetted, unit powered, but control relay does not energize. LED should light.

1. Check terminals for loose connection.
2. Check coaxial cable jack plugs for improper seating or central wire rolled loose from pin.
3. Check coaxial cable for breaks, or signal wire shorted to ground shield.
4. Check the time delay—it should be fully counterclockwise.
5. If control does not activate, consult factory.

Control output will not deactivate

1. Check transducer for plugged gap.
2. Make sure self test wiring is deactivated.
3. Check for dense foam or liquid in gap.
4. If control does not activate, consult factory.

Model 921 units

For either no signal or no signal reset, check transducer coaxial cables to make sure the upper and lower gaps are connected to the designated PC board. Refer to page 4.

AGENCY APPROVALS

Agency	Model	Approval
FM	9X1-XXXX-A1X	NEMA 4X
	9X1-XXXX-E1X 9X1-XXXX-F1X	Class I, Div. 1, Groups C & D Class II, Div. 1, Groups E, F, & G Class III, NEMA 4X
	9X1-XXXX-H1X	Class I, Div. 1, Groups B, C, & D Class II, Div. 1, Groups E, F, & G Class III, NEMA 4X
	with transducer 58X-1A22-XXX	All transducer materials approved except epoxy and polypropylene
CENELEC	9X1-XXXX-I1X	EExd IIc T6 if used with transducer 58X-1A22-XXX; 58X-1AMM-XXX 58X-1AHB-XXX; 58X-1AHC-XXX

Agency	Model	Approval
CSA	9X1-A1AX-A1X 9X1-B1CX-A1X	TYPE 4X
	9X1-A1AX-E1X 9X1-B1CX-F1X	Class I, Div. 1, Groups C & D Class II, Div. 1, Groups E, F, & G Class III, TYPE 4X
	9X1-A1AX-H1X 9X1-B1CX-H1X	Class I, Div. 1, Groups B, C, & D Class II, Div. 1, Groups E, F, & G Class III, TYPE 4X
	with transducer 58X-1A22-XXX 58X-1AHB-XXX 58X-1AHC-XXX 58X-1AMM-XXX 58X-1ATT-XXX	All transducer materials approved except CPVC, epoxy, teflon, kynar, and polypropylene

These units have been tested to EN 50081-2 and EN 50082-2 and are in compliance with the EMC Directive 89/336/EEC.

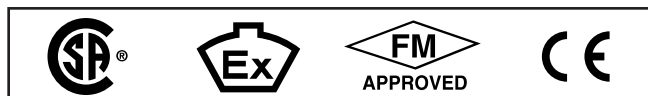

SPECIFICATIONS

DIMENSIONAL SPECIFICATIONS inches (mm)

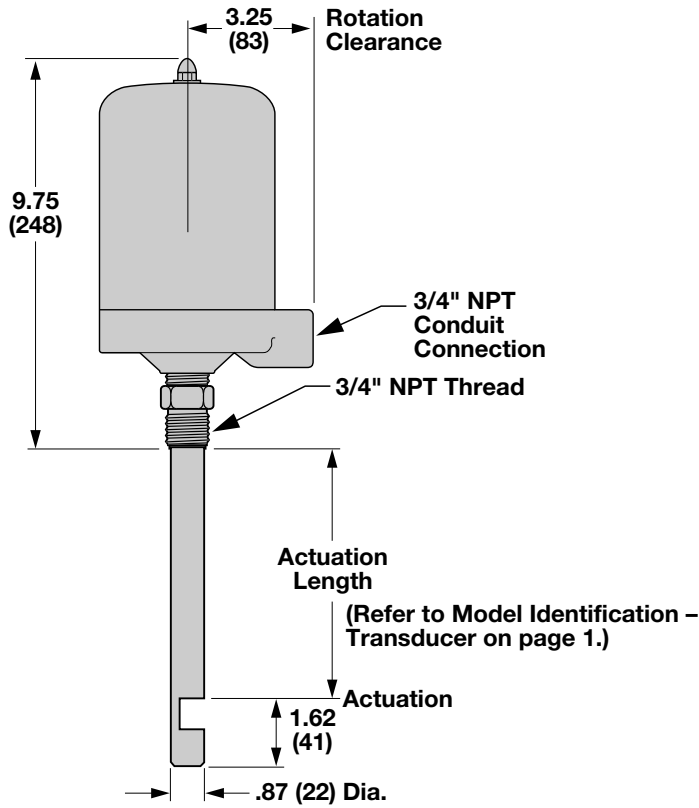

**Model 911 Integral Mount
with NEMA 4X Housing
Figure 10**

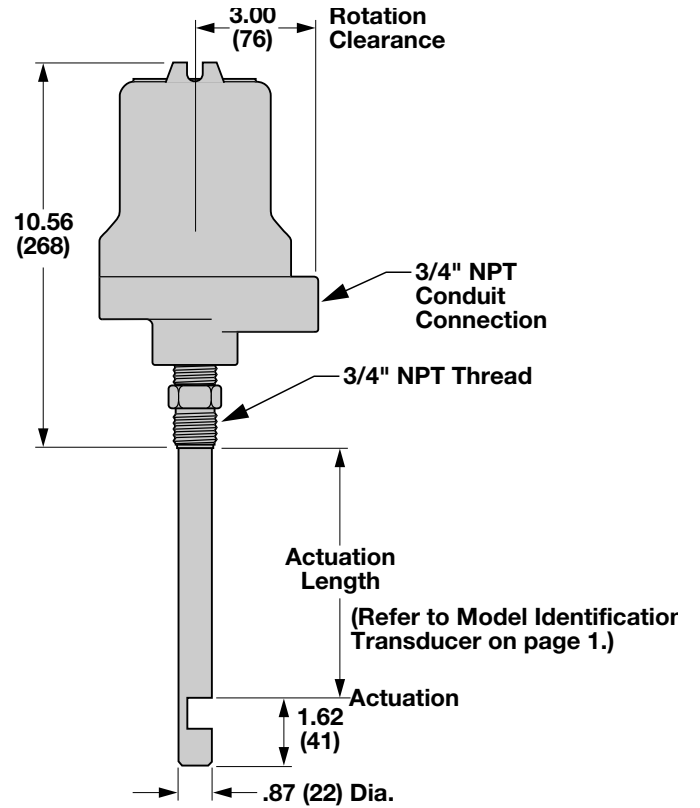

**Model 911 Integral Mount
with NEMA 4X/7/9 Housing
Figure 11**

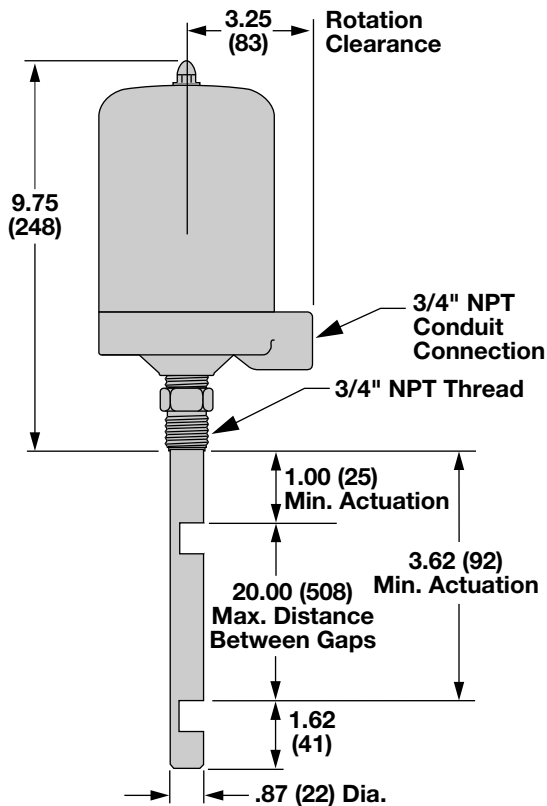

**Model 921 Integral Mount
with NEMA 4X Housing
Figure 12**

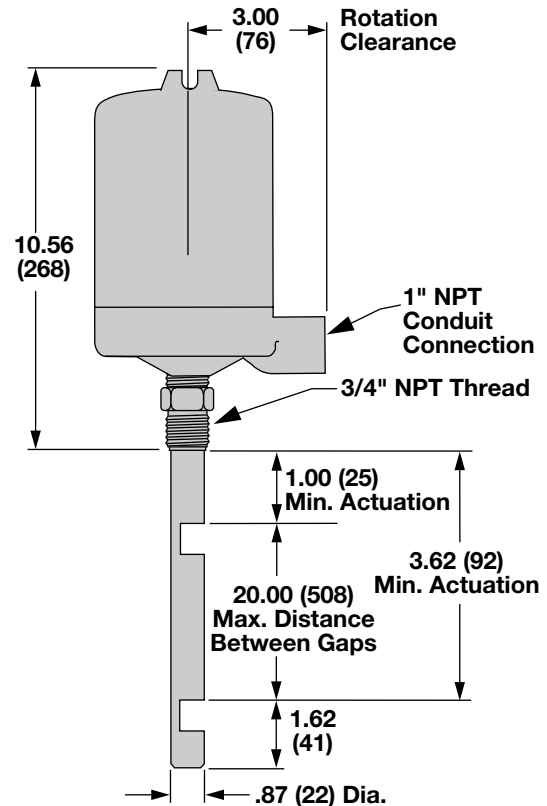

**Model 921 Integral Mount
with NEMA 4X/7/9 Housing
Figure 13**

SPECIFICATIONS

DIMENSIONAL SPECIFICATIONS inches (mm)

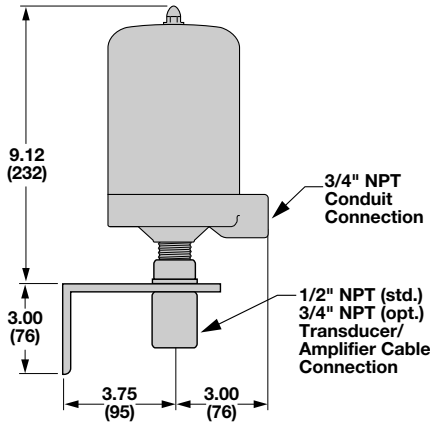

**Model 911 and 921
Remote NEMA 4X Housing
Figure 14**

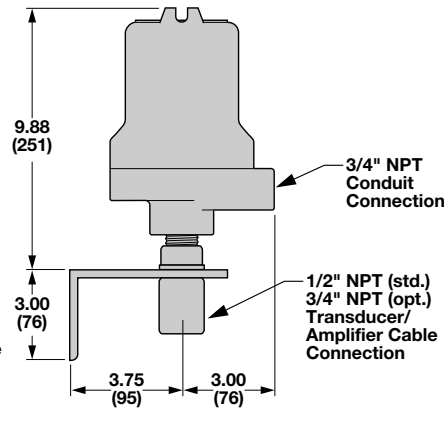

**Model 911
Remote NEMA 4X/7/9 Housing
Figure 15**

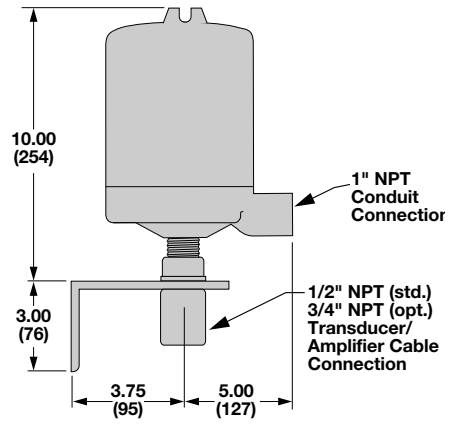

**Model 921
Remote NEMA 4X/7/9 Housing
Figure 16**

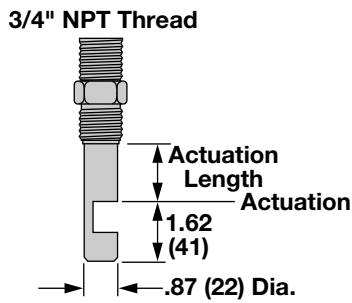

**Single Gap Transducer
Figure 17**

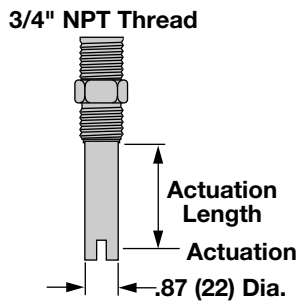

**Tip Sensitive Transducer
Single Gap Stainless Steel Only
Figure 18**

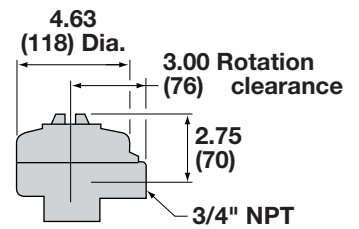

**Remote Transducer Housing
Figure 19**

SPECIFICATIONS cont.

PRESSURE AND TEMPERATURE RATINGS

Transducer	Operating / Non-Operating Pressure		Temperature
	PSIG	BAR	
316 SS	800/1500	55/103	-40° F to +250° F (-40° C to +121° C)
CPVC	100	7	-40° F to +250° F (-40° C to +121° C)
Epoxy	300 ①	21	-40° F to +100° F (-40° C to +38° C)
Hastelloy B	800/1500	55/103	-40° F to +250° F (-40° C to +121° C)
Hastelloy C	800/1500	55/103	-40° F to +250° F (-40° C to +121° C)
Kynar	100	7	+32° F to +200° F (0° C to +93° C)
Monel	800/1500	55/103	-40° F to +250° F (-40° C to +121° C)
Polypropylene	100	7	-40° F to +250° F (-40° C to +121° C)
Teflon®	100	7	+32° F to +200° F (0° C to +93° C)
Titanium	1500	103	-40° F to +250° F (-40° C to +121° C)

① Consult factory for 1000 PSIG (69 BAR) rating and higher temperatures.

ELECTRICAL SPECIFICATIONS

Description	Specifications
Power supply	120 VAC, 50/60 Hz (+10%/-15%) 240 VAC, 50/60 Hz (+10%/-15%) 24 VDC, (±10%) 12 VDC, (±10%)
Output relays	AC (1) DPDT, 240 VAC, 10 amp resistive DC (1) DPDT, 30 VDC, 10 amp resistive
Power consumption	2.5 VA nominal
Repeatability	0.078" (1.98 mm)
Fail-safe	Field selectable high or low
Time delay	0 - 60 seconds nominal
Self test	Local magnetic Remote electrical by push button
Calibration	Not required
Ambient temperature (Electronics)	-40° F to +160° F (-40° C to +71° C)

REPLACEMENT PARTS

No.	Description	Part Number		
		Model 911	Model 921	
1	PC board ①	120 VAC	030-2037-006 (qty 1)	030-2037-006 (qty 2)
		240 VAC	030-2037-007 (qty 1)	030-2037-007 (qty 2)
		24 VDC	030-2037-008 (qty 1)	030-2037-008 (qty 2)
	5 amp DPDT hermetic relay	120 VAC	030-2037-011 (qty 1)	030-2037-011 (qty 2)
		240 VAC	030-2037-012 (qty 1)	030-2037-012 (qty 2)
		24 VDC	030-2037-013 (qty 1)	030-2037-013 (qty 2)
	TTL	Consult factory		
	Open collector	Consult factory		
2	Housing cover	NEMA 4X, Carbon steel	089-6510-003	
		NEMA 4X/7/9, Cast aluminum	002-6204-600	not available
		NEMA 4X/7/9, Cast iron	004-9107-001	004-9111-001
		NEMA 4X/7/9 Group B, Cast iron	004-9111-001	
3	Cover seal	NEMA 4X	012-1318-001	
		NEMA 4X/7/9	012-2101-345	012-2501-249
4	Housing base	NEMA 4X, Carbon steel, single conduit (¾" NPT)	004-9165-002	
		NEMA 4X/7/9, Cast iron, single conduit (1" NPT)	004-9104-001	004-9138-003
		NEMA 4X/7/9 Group B, Cast iron, single conduit, (1" NPT)	004-9136-003	
5	PC board mounting bracket	005-6630-001	005-5629-001	
6	Remote electronics mounting bracket	(½" NPT)	036-3805-001	
		(¾" NPT)	036-3805-003	
7*	Remote transducer termination board ①	030-2172-001		
8	Remote transducer termination board mounting bracket	005-6634-001		
9	Remote transducer housing and base assembly	089-6585-001		
10	Coaxial cable ②	RG 178 (1 to 50 feet)	037-3155-XXX	
		RG 58 (51 to 300 feet)	037-3156-XXX	
11	Remote transducer housing assembly	056-1063-001		

① Refer to the ESD Handling Procedure on page 3.

② Two pairs required for dual point.

REPLACEMENT PARTS cont.

Transducer replacement parts

- 1a. Order transducer Series 58 model number from the units nameplate.
- 1b. Construct part number from Transducer Part Number section under Model Identification from page 1.

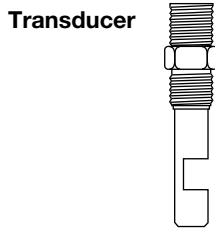

Figure 20

Sensor mounting flanges (Optional)

Raised face mounting flanges are available in the sizes and material shown below. Specify the part number as an additional line item when placing an order. Consult factory for additional flanges.

Flange		Part Number			
Size	Rating	316 SS	304 SS	Carbon Stl	Hastelloy C
1½"	150 lb.	04-5867-001	04-5867-011	04-5867-021	04-5867-031
2"		04-5867-002	04-5867-012	04-5867-022	04-5867-032
3"		04-5867-003	04-5867-013	04-5867-023	C/F
4"		04-5867-004	04-5867-014	04-5867-024	C/F
5"		04-5867-005	04-5867-015	04-5867-025	C/F
1½"	300 lb.	04-5867-006	04-5867-016	04-5867-026	04-5867-036
2"		04-5867-007	04-5867-017	04-5867-027	04-5867-037
3"		04-5867-008	04-5867-018	04-5867-028	C/F
4"		04-5867-009	04-5867-019	04-5867-029	C/F
5"		04-5867-010	04-5867-020	04-5867-030	C/F
1½"	600 lb.	04-5867-045	C/F	04-5867-046	C/F

C/F = Consult Factory

Remote Mounted Shown

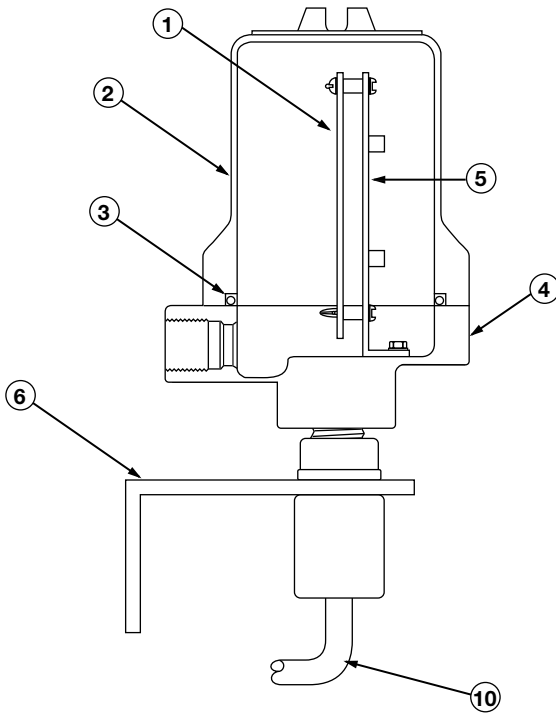

Figure 21

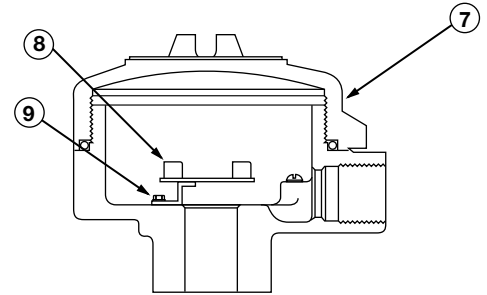

Figure 22

IMPORTANT

PRODUCT WARRANTY

All Magnetrol/STI electronic level and flow controls are warranted free of defects in materials or workmanship for one full year from the date of original factory shipment. Repair parts are warranted free of defects in materials and workmanship for one year from the date of shipment. Materials, specifications, and contents are subject to change without prior written notice.

If returned within the warranty period; and, upon factory inspection of the control, the cause of the claim is determined to be covered under the warranty; then, Magnetrol/STI will repair or replace the control at no cost to the purchaser (or owner) other than transportation.

Magnetrol/STI shall not be liable for misapplication, labor claims, direct or consequential damage or expense arising from the installation or use of equipment. There are no other warranties expressed or implied, except special written warranties covering some Magnetrol/STI products.

QUALITY ASSURANCE

The quality assurance system in place at Magnetrol/STI guarantees the highest level of quality throughout the company. Magnetrol/STI is committed to providing full customer satisfaction both in quality products and quality service.



Magnetrol's quality assurance system is registered to ISO 9001 and Z299.1 affirming its commitment to known international quality standards providing the strongest assurance of product/service quality available.

ASSURED QUALITY & SERVICE COST LESS

SERVICE POLICY

Owners of Magnetrol/STI controls may request the return of a control or any part of a control for complete rebuilding or replacement. They will be rebuilt or replaced promptly. Controls returned under our service policy must be returned by Prepaid transportation. Magnetrol/STI will repair or replace the control at no cost to the purchaser (or owner) other than transportation if:

1. Returned within the warranty period; and
2. The factory inspection finds the cause of the claim to be covered under the warranty.

If the trouble is the result of conditions beyond our control; or, is NOT covered by the warranty, there will be charges for labor and the parts required to rebuild or replace the equipment.

In some cases it may be expedient to ship replacement parts; or, in extreme cases a complete new control, to replace the original equipment before it is returned. If this is desired, notify the factory of both the model and serial numbers of the control to be replaced. In such cases, credit for the materials returned will be determined on the basis of the applicability of our warranty.

No claims for misapplication, labor, direct or consequential damage will be allowed.

LOW VOLTAGE DIRECTIVE

For use in Category II installations. If equipment is used in a manner not specified by manufacturer, protection provided by equipment may be impaired.

RETURN MATERIAL PROCEDURE

So that we may efficiently process any materials that are returned, it is essential that a "Return Material Authorization" (RMA) number be obtained from the factory, prior to the material's return. This is available through Magnetrol/STI's local representative or by contacting the factory. Please supply the following information:

1. Company Name
2. Description of Material
3. Serial Number
4. Reason for Return
5. Application

Any unit that was used in a process must be properly cleaned in accordance with OSHA standards, before it is returned to the factory.

A Material Safety Data Sheet (MSDS) must accompany material that was used in any media.

All shipments returned to the factory must be by prepaid transportation.

All replacements will be shipped F.O.B. factory.

NOTE: Refer to Electrostatic Discharge Handling Procedure on page 2.



a subsidiary of Magnetrol International, Incorporated

5300 Belmont Road • Downers Grove, Illinois 60515-4499 • 630-969-4028 • Fax 630-969-9489



5300 Belmont Road • Downers Grove, Illinois 60515-4499 • 630-969-4000 • Fax 630-969-9489 • website <http://www.magnetrol.com>
6291 Dorman Road • Mississauga, Ontario L4V-1H2 • 905-678-2720 • Fax 905-678-7407
Heikenstraat 6 • B 9240 Zele, Belgium • 052 45.11.11 • Telex 25944 • Fax 052 45.09.93
Regent Business Ctr., Jubilee Rd. • Burgess Hill, Sussex RH15 9TL U.K. • 01444-871313 • Fax 01444-871317

©1997 Magnetrol International, Incorporated. All rights reserved. Printed in the USA.
Magnetrol and Magnetrol logotype are registered trademarks of Magnetrol International.

The brand and product names contained within this document are trademarks or registered trademarks of their respective holders.

BULLETIN: 51-601.5
EFFECTIVE: January 1997
SUPERSEDES: August 1996