Read this Manual Before Installing

This manual provides information on the Echotel Model 910 Ultrasonic Liquid Level Switches. It is important that all instructions are read carefully and followed in sequence. Detailed instructions are included in the Installation section of this manual.

Conventions Used in this Manual

Certain conventions are used in this manual to convey specific types of information. General technical material, support data, and safety information are presented in narrative form. The following styles are used for notes, cautions, and warnings.

NOTES

Notes contain information that augments or clarifies an operating step. Notes do not normally contain actions. They follow the procedural steps to which they refer.

Cautions

Cautions alert the technician to special conditions that could injure personnel, damage equipment, or reduce a component's mechanical integrity. Cautions are also used to alert the technician to unsafe practices or the need for special protective equipment or specific materials. In this manual, a caution box indicates a potentially hazardous situation which, if not avoided, may result in minor or moderate injury.

WARNINGS

Warnings identify potentially dangerous situations or serious hazards. In this manual, a warning indicates an imminently hazardous situation which, if not avoided, could result in serious injury or death.

Safety Messages

The Echotel Model 910 is designed for use in Category II, Pollution Degree 2 installations. Follow all standard industry procedures for servicing electrical and computer equipment when working with or around high voltage. Always shut off the power supply before touching any components. Although high voltage is not present in this system, it may be present in other systems.

Electrical components are sensitive to electrostatic discharge. To prevent equipment damage, observe safety procedures when working with electrostatic sensitive components.

This device complies with Part 15 of the FCC rules. Operation is subject to the following two conditions: (1) This device may not cause harmful interference, and (2) This device must accept any interference received, including interference that may cause undesired operation.

WARNING! Explosion hazard. Do not connect or disconnect equipment unless power has been switched off or the area is known to be non-hazardous.

Low Voltage Directive

For use in Category II installations. If equipment is used in a manner not specified by manufacturer, protection provided by equipment may be impaired.

Notice of Trademark, Copyright, and Limitations

Magnetrol & Magnetrol logotype and Echotel are registered trademarks of Magnetrol International.

Copyright © 2011 Magnetrol International, Incorporated. All rights reserved.

Performance specifications are effective with date of issue and are subject to change without notice. Magnetrol reserves the right to make changes to the product described in this manual at any time without notice. Magnetrol makes no warranty with respect to the accuracy of the information in this manual.

Warranty

All Magnetrol Model 910 Level Switches are warranted free of defects in materials or workmanship for two full years from the date of original factory shipment.

If returned within the warranty period; and, upon factory inspection of the control, the cause of the claim is determined to be covered under the warranty; then, Magnetrol will repair or replace the control at no cost to the purchaser (or owner) other than transportation.

Magnetrol shall not be liable for misapplication, labor claims, direct or consequential damage or expense arising from the installation or use of equipment. There are no other warranties expressed or implied, except special written warranties covering some Magnetrol products.

Quality Assurance

The quality assurance system in place at Magnetrol guarantees the highest level of quality throughout the company. Magnetrol is committed to providing full customer satisfaction both in quality products and quality service.

The Magnetrol quality assurance system is registered to ISO 9001 affirming its commitment to known international quality standards providing the strongest assurance of product/service quality available.



1.0 Introduction

Echotel Model 910 Level Switches utilize ultrasonic contact technology for measuring level in clean liquid applications.

1.1 Principle of Operation

The Model 910 Level Switch uses ultrasonic energy to detect the presence or absence of liquid in a transducer gap. The basic principle behind ultrasonic contact technology is that high-frequency sound waves are easily transmitted across a transducer gap in the presence of a liquid medium, but are severely attenuated when the gap is dry. The Model 910 uses an ultrasonic frequency of 3 MHz to perform this liquid level measurement in a wide variety of process media and application conditions.

The transducer uses a pair of piezoelectric crystals that are encapsulated in epoxy at the tip of the 316 stainless steel transducer. The crystals are made of a ceramic material, that vibrates at a given frequency when subjected to an applied voltage. The transmit crystal converts an electrical signal from the Model 910 electronics into an ultrasonic signal. When liquid is present in the gap, the receive crystal is able to sense the ultrasonic signal from the transmit crystal and convert it back to an electrical signal. This signal is sent to the electronics to indicate the presence of liquid in the transducer gap. When there is no liquid present, the ultrasonic signal is attenuated, and is not detected by the receive crystal.

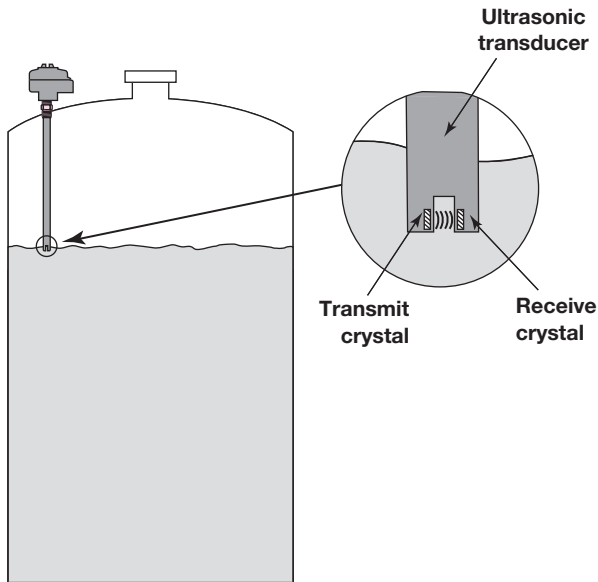

Ultrasonic signal transmission
across transducer gap

Figure 1

2.0 Installation

2.1 Unpacking

Unpack the instrument carefully. Inspect all units for damage. Report any concealed damage to carrier within 24 hours. Check the contents of the packing slip and purchase order. Check and record the serial number for future reference when ordering parts.

Model # _____

Serial # _____

2.2 Electrostatic Discharge (ESD) Handling Procedure

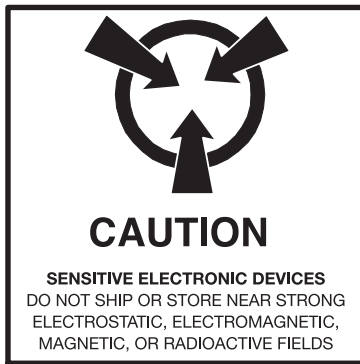

Magnetrol electronic instruments are manufactured to the highest quality standards. These instruments use electronic components that may be damaged by static electricity present in most work environments.

The following steps are recommended to reduce the risk of component failure due to electrostatic discharge.

- Ship and store circuit boards in anti-static bags. If an anti-static bag is not available, wrap the board in aluminum foil. Do not place boards on foam packing materials.
- Use a grounding wrist strap when installing and removing circuit boards. A grounded workstation is recommended.
- Handle circuit boards only by the edges. Do not touch components or connector pins.
- Make sure that all electrical connections are completely made and none are partial or floating. Ground all equipment to a good, earth ground.

2.3 Preliminary Operational Check

After unpacking and before installation, perform the following operational check on the unit in a non-hazardous area:

1. Apply proper operating voltage to terminals L1 and L2/N. Power supply ground should be connected to the green ground screw in housing base.
2. Fill a suitable container with liquid.
3. Place transducer gap in the liquid. The relay output should actuate.
4. Remove transducer from the liquid. The relay output should de-actuate. In case of malfunction, consult *Section 3.1, Troubleshooting* on page 8.

Caution: This unit contains CMOS electronics which may become damaged by static electricity. Do not touch any semiconductor devices unless you are properly grounded.

2.4 Mounting

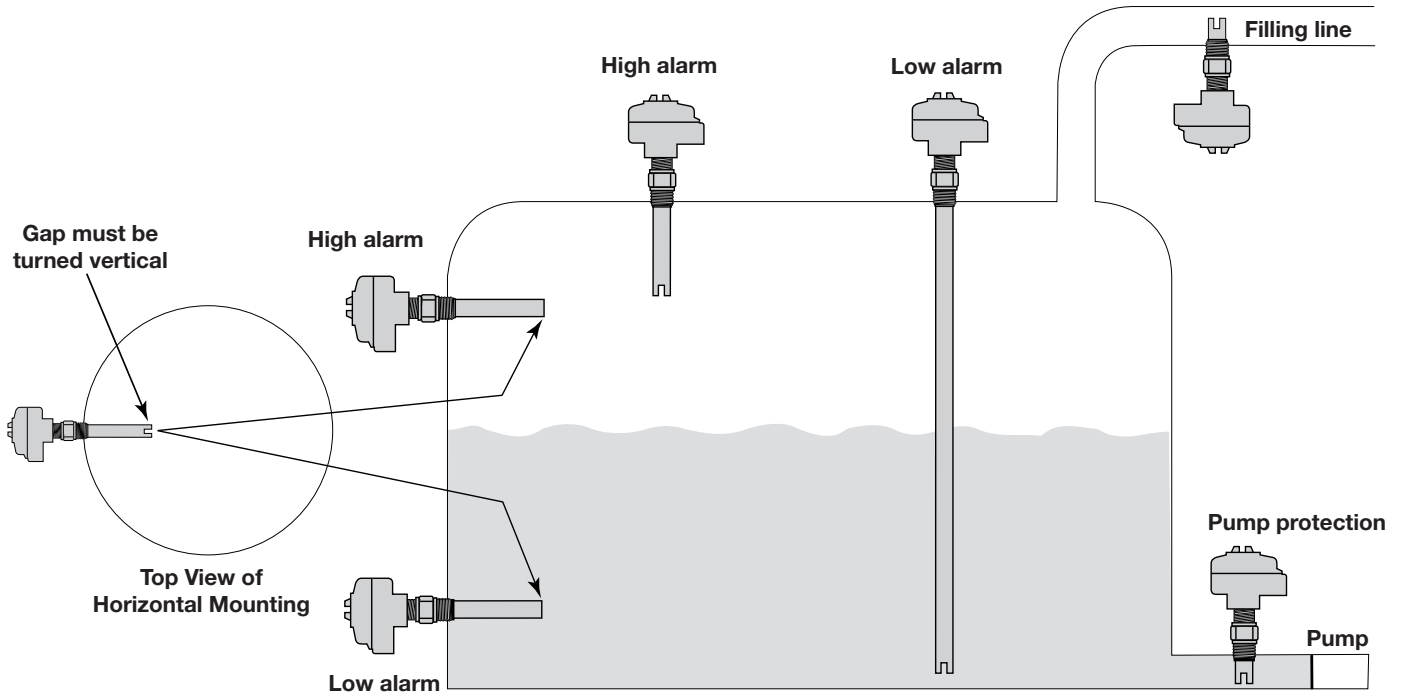

Figure 2
Typical Mounting Orientations

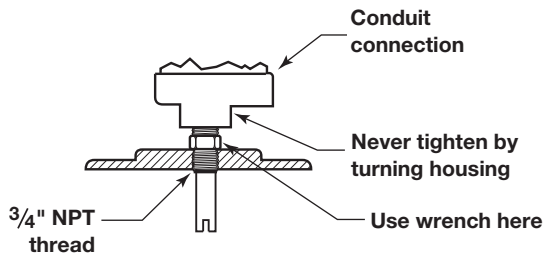

Figure 3
Vertical Mounting

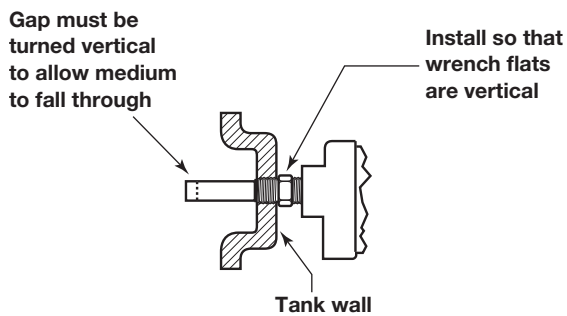

Figure 4
Horizontal Mounting

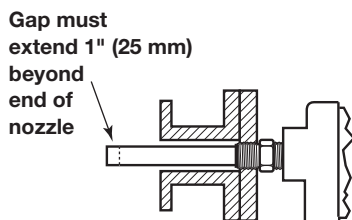

Figure 5
Nozzle Mounting

Model 910 level switches are shipped as integral units with the electronics assembled to the transducer. They may be mounted in a variety of positions as shown in Figures 2 through 5.

Proper orientation of the transducer gap will provide maximum performance in difficult applications. When the switch is mounted horizontally, the transducer gap must be turned vertical to allow proper drainage of the liquid media. See Figures 2 and 4.

Screw transducer into the opening using pipe compound or thread tape. If flanged, bolt unit to mating flange with proper gasket.

Caution: Never tighten unit on the tank connection by turning the housing. Use a wrench on the transducer mounting nut flats. Use thread tape or suitable pipe compound on the threads. Do not overtighten.

When installed in a nozzle or pipe, the transducer gap must extend into the tank at least one inch beyond the inside tank wall. Refer to Figure 5.

2.5 Wiring

2.5.1 Power

Power connections are made at the two-position terminal block labeled TB1 within the electronics enclosure. Use of 14–22 AWG wire is recommended.

NOTE: Observe all applicable electrical codes and proper wiring procedures.

1. Make sure the power is turned off.
2. Unscrew and remove the housing cover.
3. Prevent moisture seepage into housing by installing an approved seal-drain fitting in the conduit run leading to the unit.
4. Route wires into housing.
5. Connect ground wire to green ground screw located in the base of the housing. DO NOT proceed until ground connection is made.
6. After grounding is complete, connect the power leads to proper terminals as follows:

<u>VAC Units</u>	<u>VDC Units</u>
L1, L2/N	+, –

Caution: In hazardous areas, do not power the unit until the conduit is sealed and the enclosure cover is screwed down securely.

7. Dress wiring to ensure no interference or contact with cover or circuit board components.

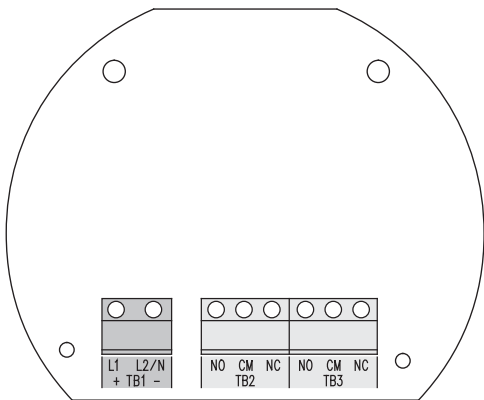

TB1 Power Wiring

2.5.2 Relay

Model 910 switches have a number of possible relay wiring options. The table below lists the relay contact positions for all possible combinations of power failure, condition of the transducer gap, and fail-safe jumper position. The user must decide which combinations constitute fail-safe and alarm conditions, and then select the appropriate relay wiring and fail-safe position.

1. Run relay output wiring to the terminal blocks labeled TB2 and TB3. Ensure that the load to be controlled is within the relay's rated capacity as shown in *Section 3.3.2, Electrical* on page 10.
2. Select high or low fail-safe using the P1 jumper.

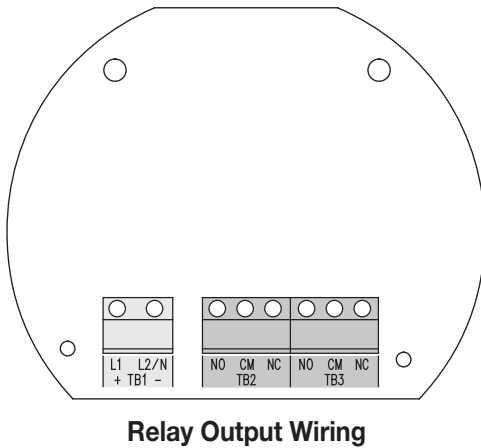

P1 Fail-safe Jumper Position	Line Power	Transducer Gap	Relay Terminals	
			CM to NC	CM to NO
Low level	On	Dry	Closed	Open
		Wet	Open	Closed
	Failure	Dry	Closed	Open
		Wet	Closed	Open
High level	On	Dry	Open	Closed
		Wet	Closed	Open
	Failure	Dry	Closed	Open
		Wet	Closed	Open

3. Replace housing cover. Installation is complete.

Caution: Never tighten unit to the tank connection by turning the housing. Use a wrench on the transducer mounting nut flats. Use thread tape or suitable pipe compound on threads. Do not overtighten.

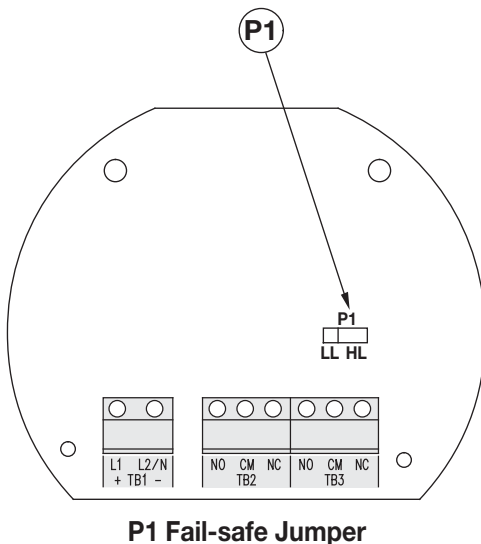

3.0 Reference Information

3.1 Troubleshooting

Caution: In hazardous areas, do not remove housing cover until power is disconnected and atmosphere is determined to be safe.

3.1.1 No signal with level change

- Verify power and control circuit wiring.
- Make sure liquid is filling the transducer gap.
- Check for dense foam on surface or dried product in the gap. Unit will not function properly if either condition exists.
- Check transducer phone plugs for proper insertion in J1 and J2.
- If control circuit does not actuate, consult factory.

3.1.2 Calibration

Model 910 switches do not require field calibration. The set point is not adjustable.





3.1.3 Switch chatter

- Check voltage to make sure it is within tolerances shown in Section 3.3.2.
- Check for turbulence. Relocate control or isolate from turbulence.
- Check for excessive aeration.
- Consult factory.

3.1.4 Control output will not de-actuate

- Check transducer for plugged gap.
- Check for dense foam or liquid in gap.
- If control circuit does not de-actuate, consult factory.

3.2 Agency Approvals

AGENCY	APPROVED MODEL	PROTECTION METHOD	AREA CLASSIFICATION
	910-XXXX-XXX	Explosion Proof	Class I, Div. 1; Groups B, C & D Class II, Div. 1; Groups E, F, & G Class III, NEMA Type 4X, T6
	910-XXXX-XXX	Non-Incendive	Class I, Div. 2; Groups A, B, C, & D Class II, Div. 2; Groups F & G Class III, NEMA Type 4X, T5
	910-XXXX-XXX	Explosion Proof	Class I, Div. 1; Groups C & D Class II, Div. 1; Group E, F, & G Class III, Type 4X, T6
	910-XXXX-XXX	Non-Incendive	Class I, Div. 2; Groups A, B, C, & D Class II, Div. 2; Groups E, F, & G Class III, Type 4X, T5
	910-5XXX-XXX		 II 1/2 G EEx d II C T6/EEx e II T6
	910-PXXX-XXX		

Note: Consult factory for Brazilian INMETRO BR-Ex d IIC T6 IP66 approval.



These units have been tested to EN 50081-2 and EN 50082-2 and are in compliance with the EMC Directive 89/336/EEC.

3.3 Specifications

3.3.1 Physical

inches (mm)

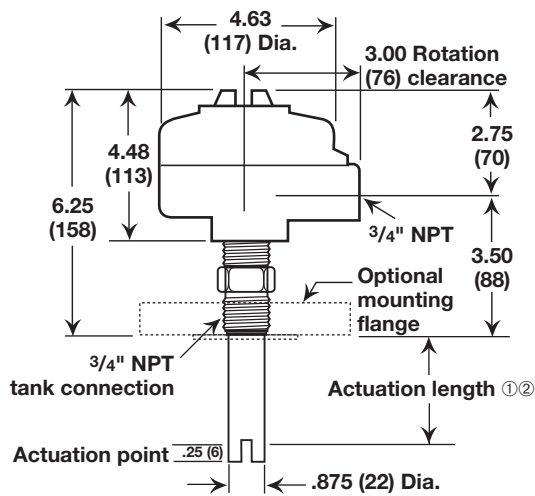

**316 stainless steel housing
(Single 3/4" NPT conduit)**

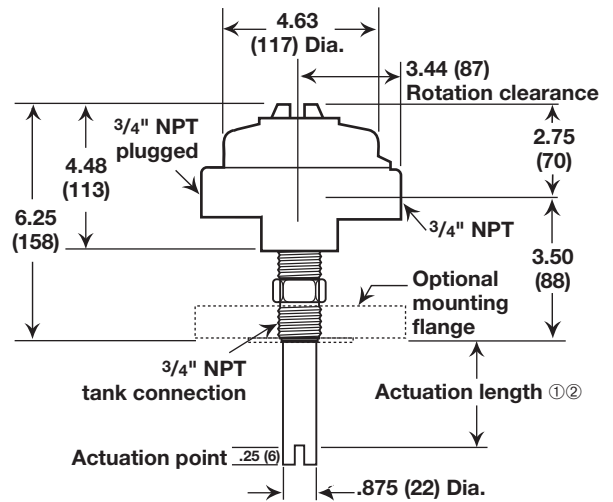

**Aluminum sand cast housing
(Dual 3/4" NPT conduits)**

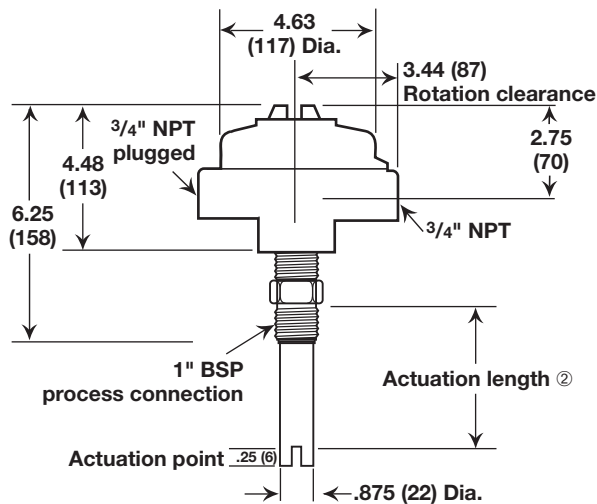

**Aluminum sand cast housing
(Dual 3/4" NPT conduit w/1" BSP process connection)**

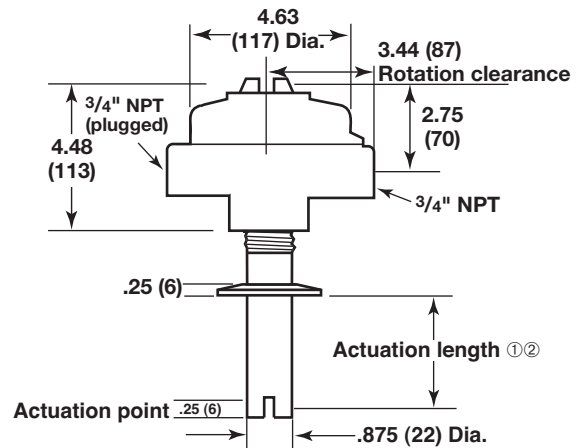

**Aluminum sand cast housing
(Dual 3/4" NPT conduit with hygienic flange)**

- ① 1" (Code 001) minimum with NPT threaded process connections.
- 2" (Code 002) minimum with hygienic or ANSI flanged process connections.

- ② .25 (Code 003) mm minimum with NPT threaded process connections.
- 50 (Code 005) mm minimum with 1" BSP, and hygienic or ANSI flanged process connections.

3.3.2 Electrical

Power Supply:	120 VAC (+10%/-15%), 50/60 Hz 240 VAC (+10%/-15%), 50/60 Hz 24 VDC (±10%)
Power Consumption:	2.5 VA nominal
Relay Output:	Gold flash DPDT relay: 10 amps @ 120 VAC, 240 VAC, 24 VDC ① Hermetically sealed DPDT relay: 5 amps @ 120 VAC, 24 VDC, and 3 amps @ 240 VAC
Repeatability:	0.078" (2 mm)
Fail-safe Configuration:	Field selectable high or low
Calibration:	None required
Ambient Temperature:	Electronics: -40° to +158° F (-40° to +70° C)
Process Temperature:	Transducer: -40° to +250° F (-40° to +121° C)
Operating/Non-Operating Pressure:	800/1500 psig (55/103 bar)
Shock	ANSI/ISA-S71.03 Class SA1
Vibration	ANSI/ISA-S71.03 Class VC2

① Gold flash DPDT relay is rated at 8 amps when used with housing codes 5 or P

3.4 Replacement Parts

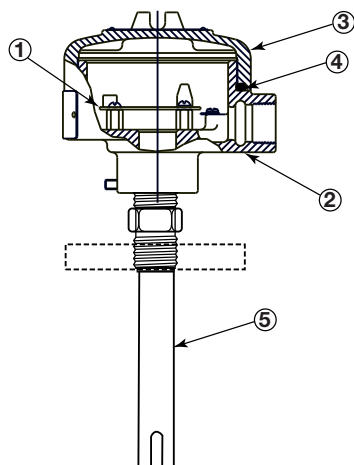

No.		Description	Part Number
1	PC Board	120 VAC w/10 amp relay	Z30-2043-003
		240 VAC w/10 amp relay	Z30-2043-004
		24 VDC w/10 amp relay	Z30-2043-002
		120 VAC w/5 amp HS relay	Z30-2043-011
		240 VAC w/3 amp HS relay	Z30-2043-012
		24 VDC w/5 amp HS relay	Z30-2043-010
2	Housing Base	Aluminum w/FM and CSA	004-9182-002
		Aluminum w/all 3 approvals	004-9182-008
		316 SS w/FM and CSA	004-9140-001
		316 SS w/CENELEC	004-9140-001
3	Housing Cover	Aluminum w/FM and CSA	004-9105-001
		Aluminum w/all 3 approvals	004-9105-005
		316 SS w/FM and CSA	004-9142-001
		316 SS w/CENELEC	004-9142-001
4	O-Ring		012-2101-345
5	Transducer		Consult factory

WARNING! Explosion hazard — Substitution of components may impair suitability for Class 1, Division 2 rating.

WARNING! Explosion hazard — Do not disconnect equipment unless power has been switched off, or the area is known to be non-hazardous.

3.5 Model Numbers

3.5.1 Model 910

HOUSING

A	Aluminum sand cast with 3/4" NPT dual conduit, FM or CSA approvals
Y	316 stainless steel with 3/4" NPT single conduit, FM or CSA approvals
P	Aluminum sand cast with 3/4" NPT dual conduit, FM, CSA and ATEX approvals
5	316 stainless steel with 3/4" NPT single conduit, ATEX approval

TRANSDUCER UNIT OF LENGTH

1	English (actuation length in inches)
M	Metric (actuation length in centimeters)

PROCESS CONNECTION

A	3/4" NPT
2	1" NPT
9	1" BSP
3	1 1/2" hygienic flange (Compatible with Tri-Clamp® fittings)
4	2" hygienic flange (Compatible with Tri-Clamp® fittings)
1	1" 150 lb. ANSI raised face flange
C	1 1/2" 150 lb. ANSI raised face flange
D	2" 150 lb. ANSI raised face flange
E	1" 300 lb. ANSI raised face flange
F	1 1/2" 300 lb. ANSI raised face flange
G	2" 300 lb. ANSI raised face flange

INPUT POWER

0	120 VAC with 10 amp DPDT gold flash relay
1	240 VAC with 10 amp DPDT gold flash relay
2	24 VDC with 10 amp DPDT gold flash relay
H	120 VAC with 5 amp DPDT hermetically sealed relay
J	240 VAC with 3 amp DPDT hermetically sealed relay
K	24 VDC with 5 amp DPDT hermetically sealed relay

ACTUATION LENGTH

1" to 96" in 1" increments (with Transducer Unit of Length code 1) Example: 4 inches = 004 ① ③

3 cm to 244 cm in 1 cm increments (with Transducer Unit of Length code M) Examples: 6 centimeters = 006 ② ③



① 1" (code 001) minimum with NPT process connections, 2" (code 002) minimum with hygienic or ANSI flanged process connections.

② 2.5 cm (code 003) minimum with NPT process connections, 5 cm (code 005) minimum with 1" BSP, or hygienic or ANSI flanged process connections.

③ Consult factory for longer lengths.

Service Policy

Owners of Magnetrol may request the return of a control or any part of a control for complete rebuilding or replacement. They will be rebuilt or replaced promptly. Controls returned under our service policy must be returned by Prepaid transportation. Magnetrol will repair or replace the control at no cost to the purchaser (or owner) other than transportation if:

1. Returned within the warranty period; and
2. The factory inspection finds the cause of the claim to be covered under the warranty.

If the trouble is the result of conditions beyond our control; or, is NOT covered by the warranty, there will be charges for labor and the parts required to rebuild or replace the equipment.

In some cases it may be expedient to ship replacement parts; or, in extreme cases a complete new control, to replace the original equipment before it is returned. If this is desired, notify the factory of both the model and serial numbers of the control to be replaced. In such cases, credit for the materials returned will be determined on the basis of the applicability of our warranty.

No claims for misapplication, labor, direct or consequential damage will be allowed.

Return Material Procedure

So that we may efficiently process any materials that are returned, it is essential that a "Return Material Authorization" (RMA) number be obtained from the factory, prior to the material's return. This is available through a Magnetrol local representative or by contacting the factory. Please supply the following information:

1. Company Name
2. Description of Material
3. Serial Number
4. Reason for Return
5. Application

Any unit that was used in a process must be properly cleaned in accordance with OSHA standards, before it is returned to the factory.

A Material Safety Data Sheet (MSDS) must accompany material that was used in any media.

All shipments returned to the factory must be by prepaid transportation.

All replacements will be shipped F.O.B. factory.

NOTE: See Electrostatic Discharge Handling Procedure on page 4.

