



MAGNETROL  
REGISTERED TO  
**ISO 9001**  
Your Assurance of  
Quality and Service

# Echotel® Trident 91S/92S Ultrasonic Level Switches

## Instruction Manual and Parts List



Model 91S



Model 92S

### MODEL IDENTIFICATION

Each unit has a nameplate on which the part number is shown. The part number is coded to identify the configuration of that specific unit. Listed below are the definitions of each section of the part number, such that one can determine exactly which options the unit contains.

### 91S PART NUMBER CONSTRUCTION

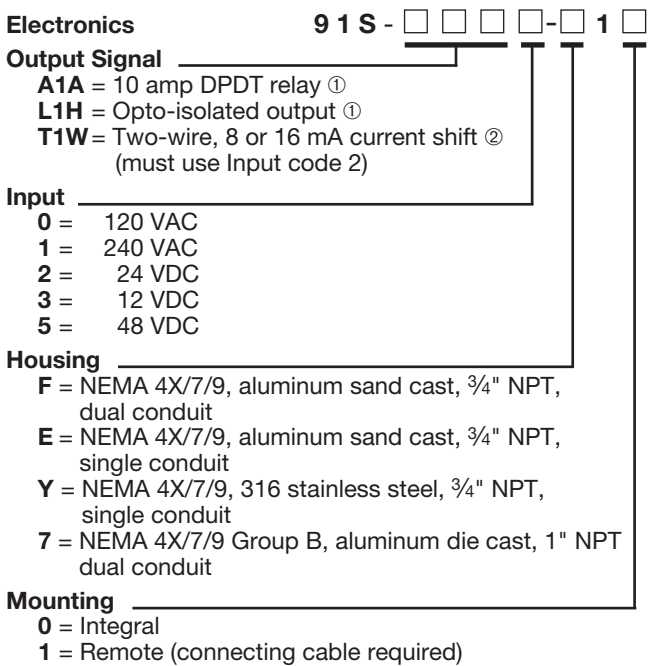

① Model 91S with output signal option code A1A or L1H available with housing option codes F or 7 only.  
② Model 91S with output signal option code T1W available with housing option codes E or Y only.

### 91S PART NUMBER CONSTRUCTION cont.

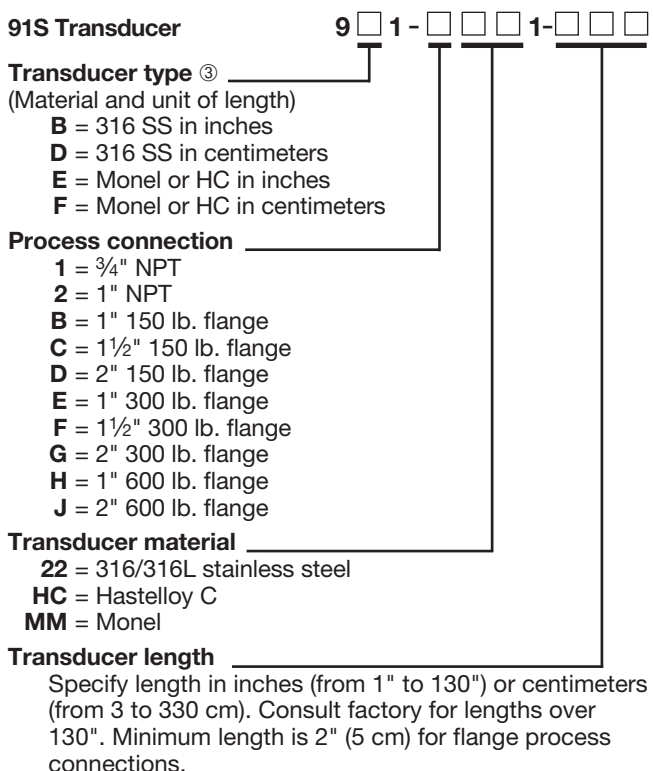

③ 316 SS Model 91S transducers have tip sensitive gaps as shown in Figure 19 on page 17. Monel and Hastelloy C Model 91S transducers have side gaps as shown in Figure 21 on page 18.

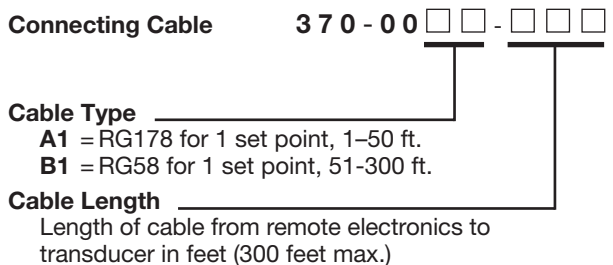

**92S PART NUMBER CONSTRUCTION**

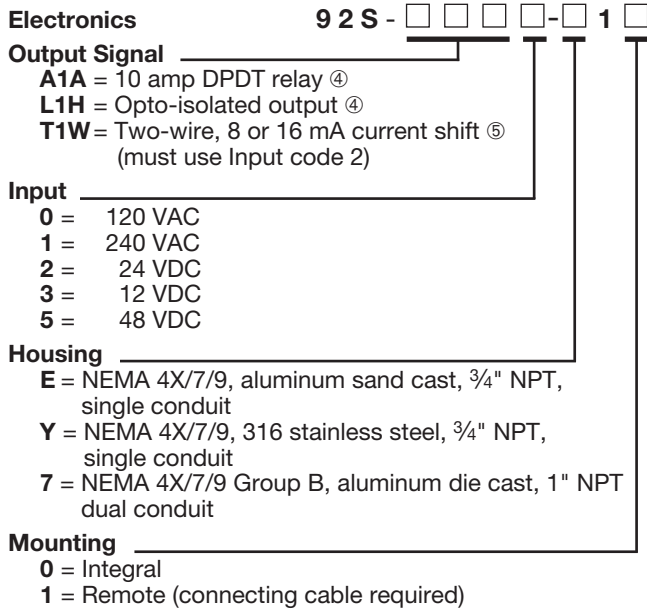

④ Model 92S with output signal option code A1A or L1H available with housing option code 7 only.  
 ⑤ Model 92S with output signal option code T1W available with housing option codes E, Y, and 7.

**92S PART NUMBER CONSTRUCTION cont.**

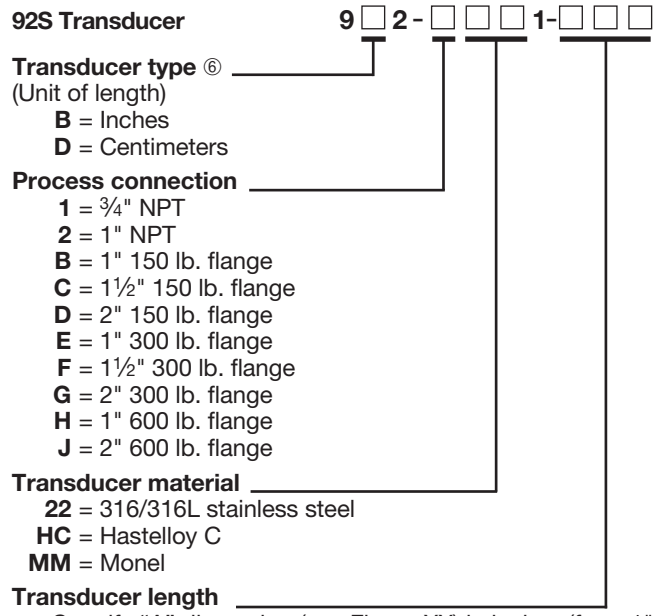

⑥ All Model 92S transducers (316 SS, HC, and Monel) have dual side gaps, as shown in Figure 17 on page 17

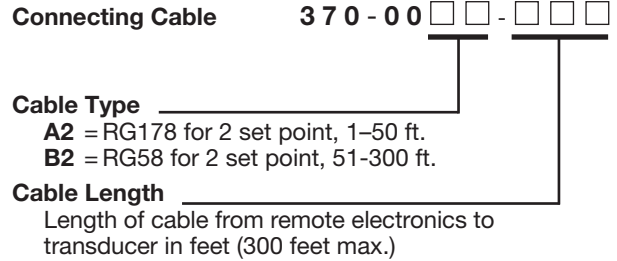

# GENERAL INFORMATION

## PRINCIPLE OF OPERATION

The Trident Model 91S/92S operates on a two crystal pulsed or “transmit-receive” principle which applies a high frequency electronic burst to the transmit crystal. The signal is then converted into ultrasonic sound energy and transmitted across the sensing gap toward the receive crystal. When air is in the gap, the high frequency sound energy will be attenuated, thereby not allowing the energy to be received. When there is liquid in the gap, the sound energy will propagate across the gap and the relay control or current shift output will indicate such a reception of the signal.

Self testing is accomplished without any additional crystals and a minimum of additional circuitry. The electronics detection circuit looks for low amplitude signals that pass between

## PRINCIPLE OF OPERATION cont.

the crystals through the frame of the sensor. This allows the entire sensor, including the bond between the crystals and the sensor face, to be tested along with the electronics.

## UNPACKING/SPECIAL HANDLING CONSIDERATIONS

Before unpacking the unit, please familiarize yourself with the procedures and cautions regarding the handling of Electrostatic Discharge (ESD) sensitive equipment.

**CAUTION:** Trident Model 91S/92S units are Electrostatic Discharge (ESD) sensitive instruments. Follow ESD handling procedures on page 4 when servicing this equipment to avoid circuit damage.

## PRELIMINARY OPERATIONAL CHECK

**CAUTION:** Phono jack plugs are fragile. Do not pull plugs from PC board by pulling coaxial cable.

1. See appropriate wiring for Four-Wire/Two-Wire and single point/dual point models (pages 4–10) and wire unit.
2. Fill a suitable container with water.
3. Place transducer gap in the liquid.

**NOTE:** THE AMPLIFIER BOARD AND POWER SUPPLY BOARD WILL BE DISCUSSED THROUGHOUT THIS MANUAL. THE POWER SUPPLY BOARD IS SHOWN IN FIGURES 4, 5, 6, AND 7, DEPENDING ON THE VERSION. THE AMPLIFIER BOARD IS SHOWN IN FIGURES 9, 11, AND 12.

### Single point (91S) models

**Relay Versions:** Once the liquid fills the gap, there should be an audible click as the relay changes state. Also, the red LED marked LED1 (WET) on the amplifier board will illuminate. Depending on how the unit is configured, the red LED marked DS1 on the power supply board may also illuminate. For the purposes of this preliminary check, only the LEDs on the amplifier board are pertinent.

**Current Shift Versions:** Once the liquid fills the gap, the current output value should change from 8 mA to 16 mA, and LED1 (WET) on the amplifier board will illuminate.

### Dual point (92S) models

**Relay Versions:** Place the lower transducer gap in the liquid. There will be an audible click as the relay changes state. The red LED marked LED1 (WET) on the bottom amplifier board will illuminate. Continue to immerse the transducer until the top gap is filled with liquid. Once

### Dual point (92S) models cont.

again, there will be an audible click as the relay changes state and the red LED marked LED1 (WET) on the top board will illuminate.

**Current Shift Versions:** Once liquid fills the lower gap, the current output value should change from 8 mA to 16 mA, and the red LED marked LED1 (WET) on the bottom amplifier board will illuminate. Continue to immerse the transducer until the top gap is filled with liquid. Once again, the current output value will change from 8 mA to 16 mA and the red LED marked LED1 (WET) on the top amplifier board will illuminate.

4. Remove transducer from the liquid. The control output must deactivate or current shift value return to 8 mA\* and the green LED marked LED2 (DRY) will illuminate. In case of malfunction consult the Troubleshooting section on page 15.

## MANUAL SELF-TEST

**Wet Self Test:** With power applied to the instrument and no liquid in the sensor gap, press switch S2 marked WET TEST on the amplifier board. Red LED1 (WET) on the amplifier and DS1 power supply board will illuminate, and green LED marked LED2 (DRY) on the amplifier board will extinguish.

**Manual Self Test:** Press switch S1 marked MALF TEST on the amplifier board. With P2 jumper on the amplifier board in (HIGH) position both LEDs on the amplifier board will illuminate. With P2 jumper in (LOW) position, both LEDs will extinguish. Output current should be 19 mA or 5 mA respectively.\*

\* Two wire (current shift) models only.

## MOUNTING POSITION AND LOCATION

### MOUNTING POSITION AND LOCATION

Unit may be mounted in any position or orientation. Refer to Figures 1 and 2.

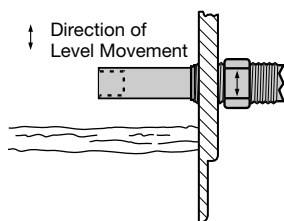

Figure 1  
Horizontal Mounting  
(91S only)

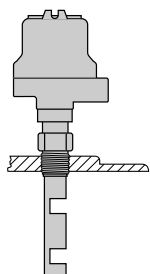

Figure 2 – Vertical Mounting

### MOUNTING POSITION AND LOCATION cont.

When installed in a nozzle or pipe, the transducer gap must extend into the tank beyond the inside tank wall. Refer to Figure 3.

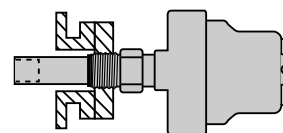

Figure 3 – Horizontal Mounting in Nozzle

All wiring, conduit and electrical fittings must conform to local electrical codes for the location selected.

# ELECTROSTATIC DISCHARGE (ESD) HANDLING PROCEDURE

Magnetrol's electronic instruments are manufactured to the highest quality standards. These instruments utilize electronic components which may be damaged by static electricity present in most work environments. The following steps are recommended to reduce the risk of component failure due to electrostatic discharge:

1. Ship and store circuit boards in anti-static bags. If an anti-static bag is not available, wrap board in aluminum foil. Do not place boards on foam packing materials.

2. Use a grounding wrist strap when installing and removing circuit boards. A grounded workstation is also recommended.
3. Handle printed circuit boards only by the edges. Do not touch components or connector pins.
4. Ensure that all electrical connections are completely made and none are partial or floating. Ground all equipment to a good, earth ground.

## FOUR-WIRE MODELS (RELAY or OPTO-ISOLATED VERSIONS) INSTALLATION/WIRING

### 91S SINGLE POINT WIRING

**CAUTION:** Never tighten unit to the tank connection by turning the housing. Use a wrench on the transducer mounting nut flats. Use thread tape or suitable pipe compound on threads. Do not over tighten.

1. Screw transducer into the vessel opening using pipe compound or thread tape. If flanged, bolt unit to mating flange with proper gasket.
2. Remove housing cover.
3. No. 14 AWG wire size is recommended for power and relay wiring.
4. Route wires into housing. Prevent moisture seepage into the enclosure by installing approved seal-drain fittings in the conduit run leading to the unit.

**NOTE:** FOR 91S 120/240 VAC W/OPTO-ISOLATED OUTPUT, REFER TO FIGURE 5 ON PAGE 5. FOR 91S 24 VDC W/OPTO-ISOLATED OUTPUT, REFER TO FIGURE 6 ON PAGE 5.

### 91S SINGLE POINT WIRING cont.

5. Attach power leads to power terminal block TB1 on left side of power supply PC board. Power to properly marked terminals ([+]L1 and [-]N). Run ground wire to green screw on bracket. Refer to Figure 4 for 120/240 VAC version.
6. Run alarm relay wiring to terminal block TB2.
7. Dress wiring to ensure no interference or contact with cover or circuit board components.

**OBSERVE ALL APPLICABLE ELECTRICAL CODES AND PROPER WIRING PROCEDURES.**

**NOTE:** IF REMOTE SELF-TEST IS USED, FOLLOW INSTRUCTIONS ON PAGE 6.

8. If using the malfunction relay, run wiring to lower portion of TB1 as shown in Figure 4.
9. Replace housing cover.

**CAUTION:** In hazardous areas, do not power the unit until the conduit is sealed and enclosure cover is screwed down securely.

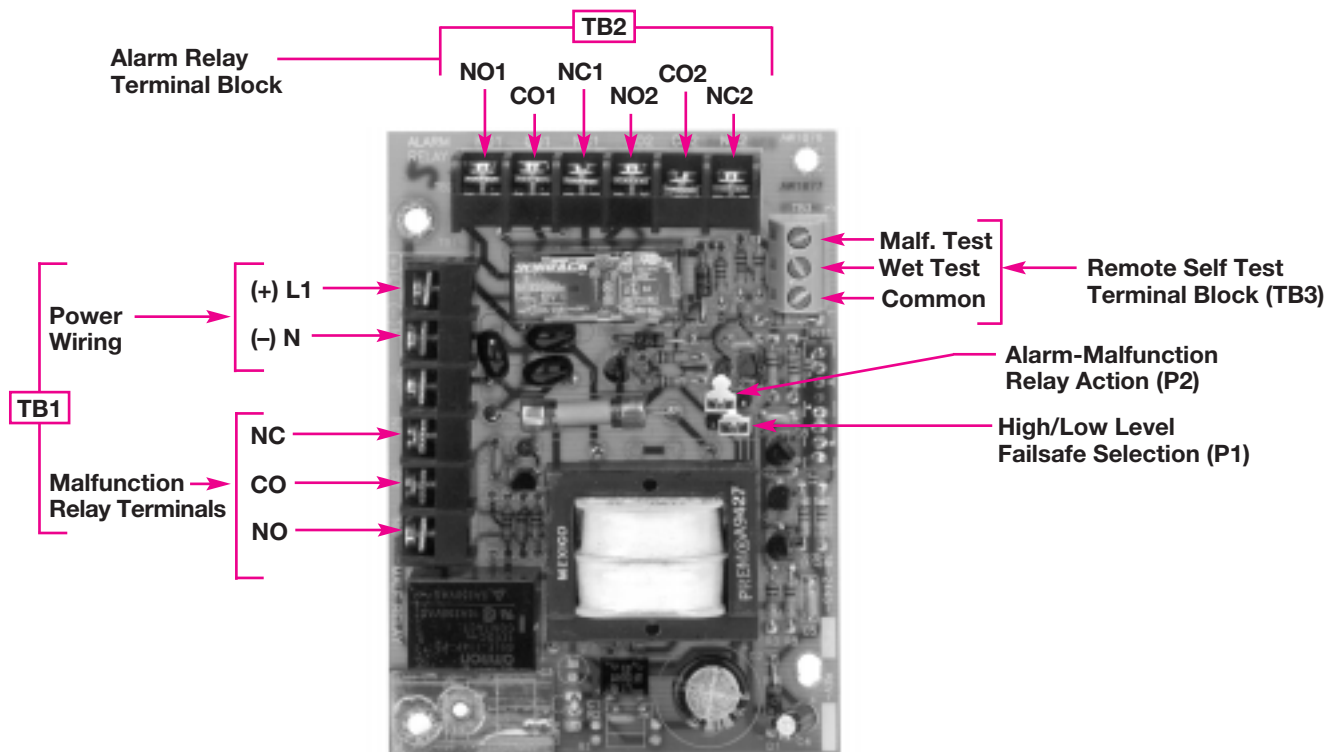

Figure 4

91S Relay Output, 120/240 VAC Power Supply Board

# FOUR-WIRE MODELS (RELAY/OPTO-ISOLATED) INSTALLATION/WIRING cont.

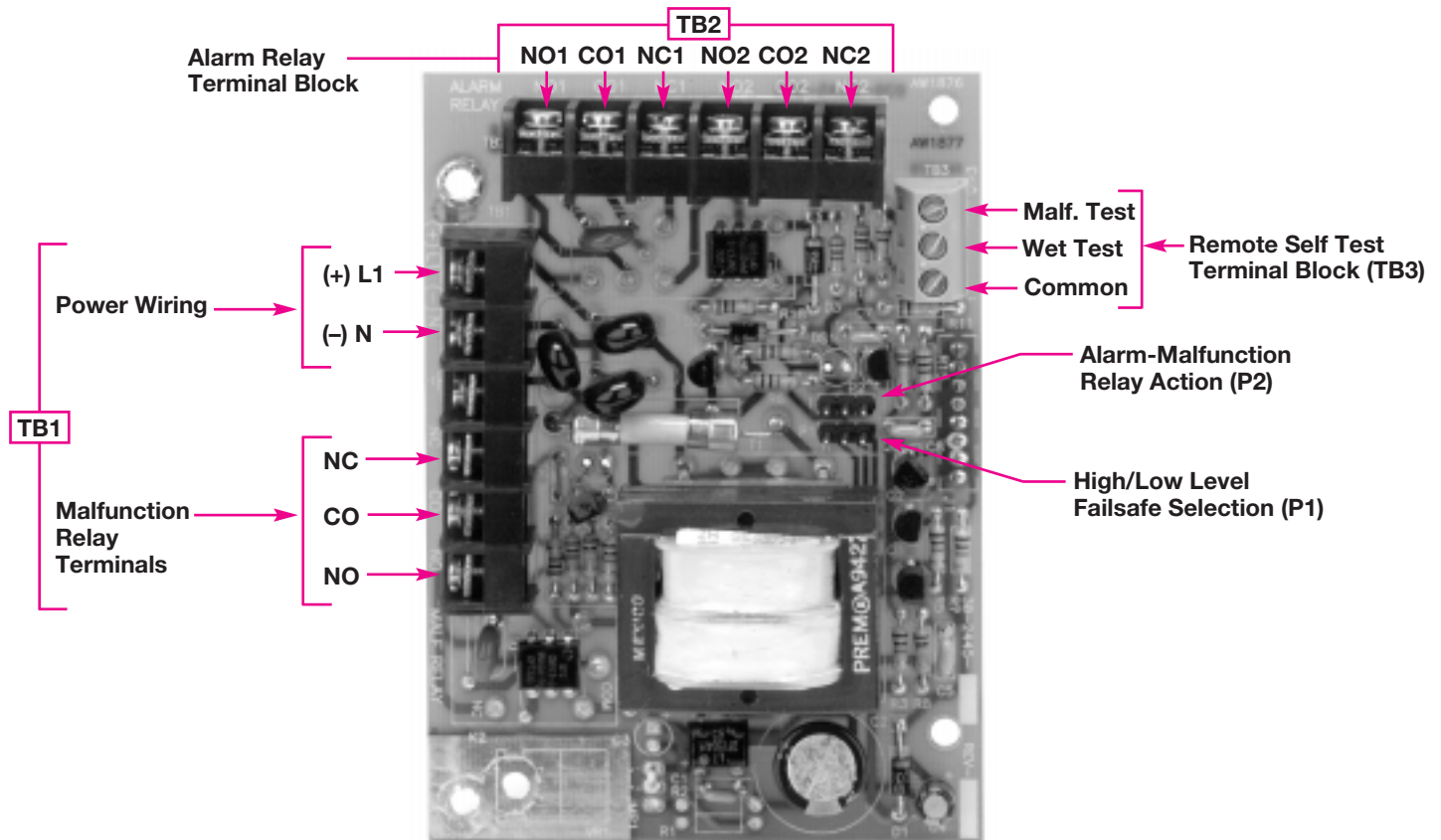

Figure 5  
91S Opto-Isolated Output, 120/240 VAC Power Supply Board

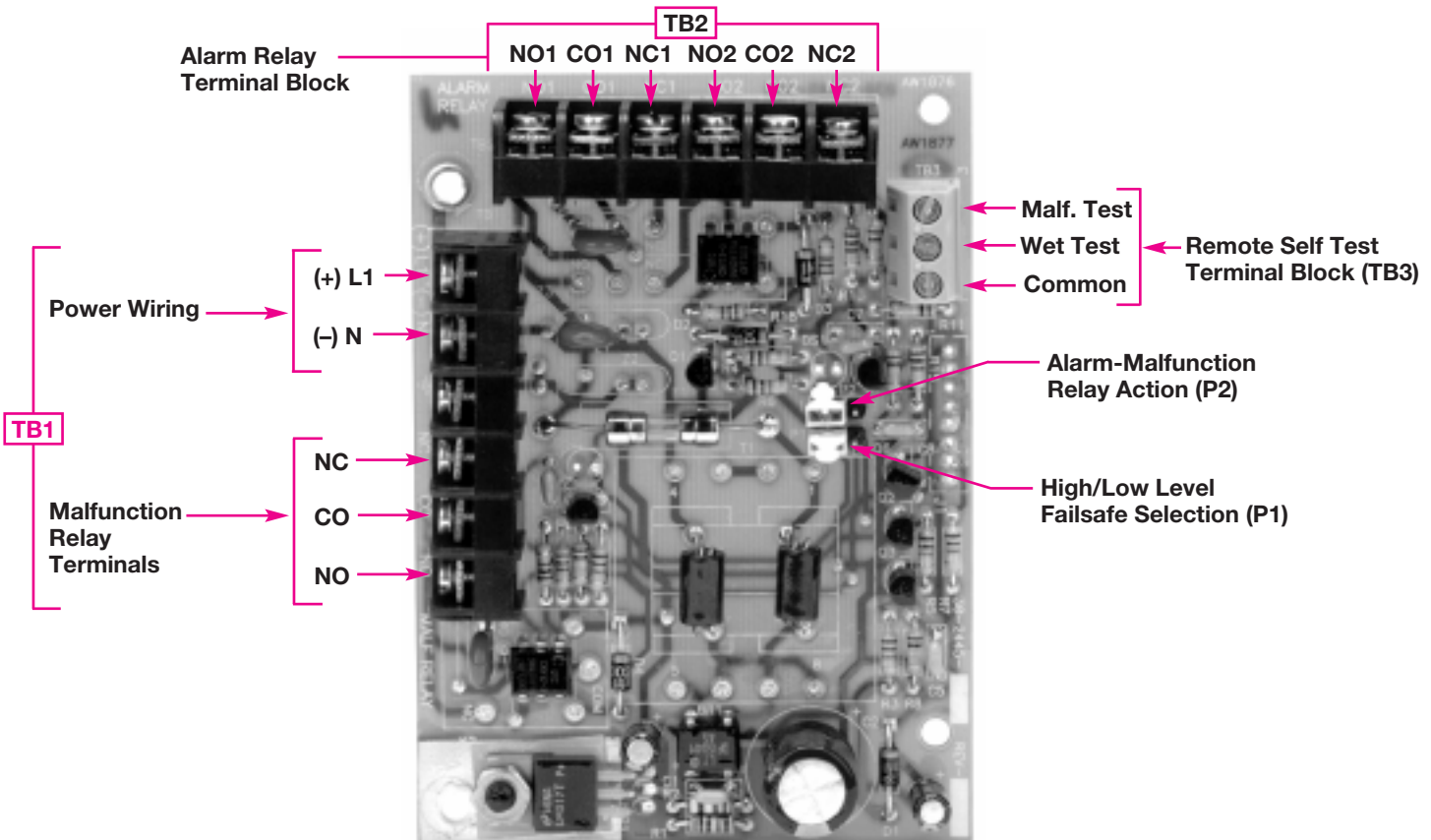

Figure 6  
91S Opto-Isolated Output, 24 VDC Power Supply Board

# FOUR-WIRE MODELS (RELAY/OPTO-ISOLATED)

## INSTALLATION/WIRING cont.

### 92S DUAL POINT WIRING

1. Run power leads to power terminal block TB1 on the lower left side of the power supply board. Refer to Figure 7.
2. Run alarm relay wiring for upper (top) level point to TB2 and lower (bottom) level point to TB3.
3. If using malfunction relay, run wiring to upper terminals marked TB1. Remember, only one malfunction relay is present for both boards.
4. Auto fill or auto empty can be accomplished with the use of one control relay.

### REMOTE MANUAL SELF-TEST WIRING (91S/92S)

Remote self test is accomplished by connecting remote test switches to terminal block TB3 for 91S. For 92S, connect remote test switches to TB4 and TB5.

**NOTE:** The remote manual self test terminal block is not available on the two-wire loop-powered single and dual point versions.

1. Use single twisted pair 18-22 AWG wire to connect to TB3 on single point power supply board, or TB4 and TB5 for dual point.
2. Determine whether a manual test on a wet condition or malfunction is desirable. (See page 15.)

**DO NOT WIRE SEPARATE 12 VDC POWER SOURCE TO GENERATE POWER FOR REMOTE PUSH BUTTON SELF TEST. POWER IS ALREADY AT THE TERMINALS.**

3. Run one wire of the twisted pair to the W (wet) or M (malfunction) position. Run the second wire of the pair to the blank terminal position marked C (common).

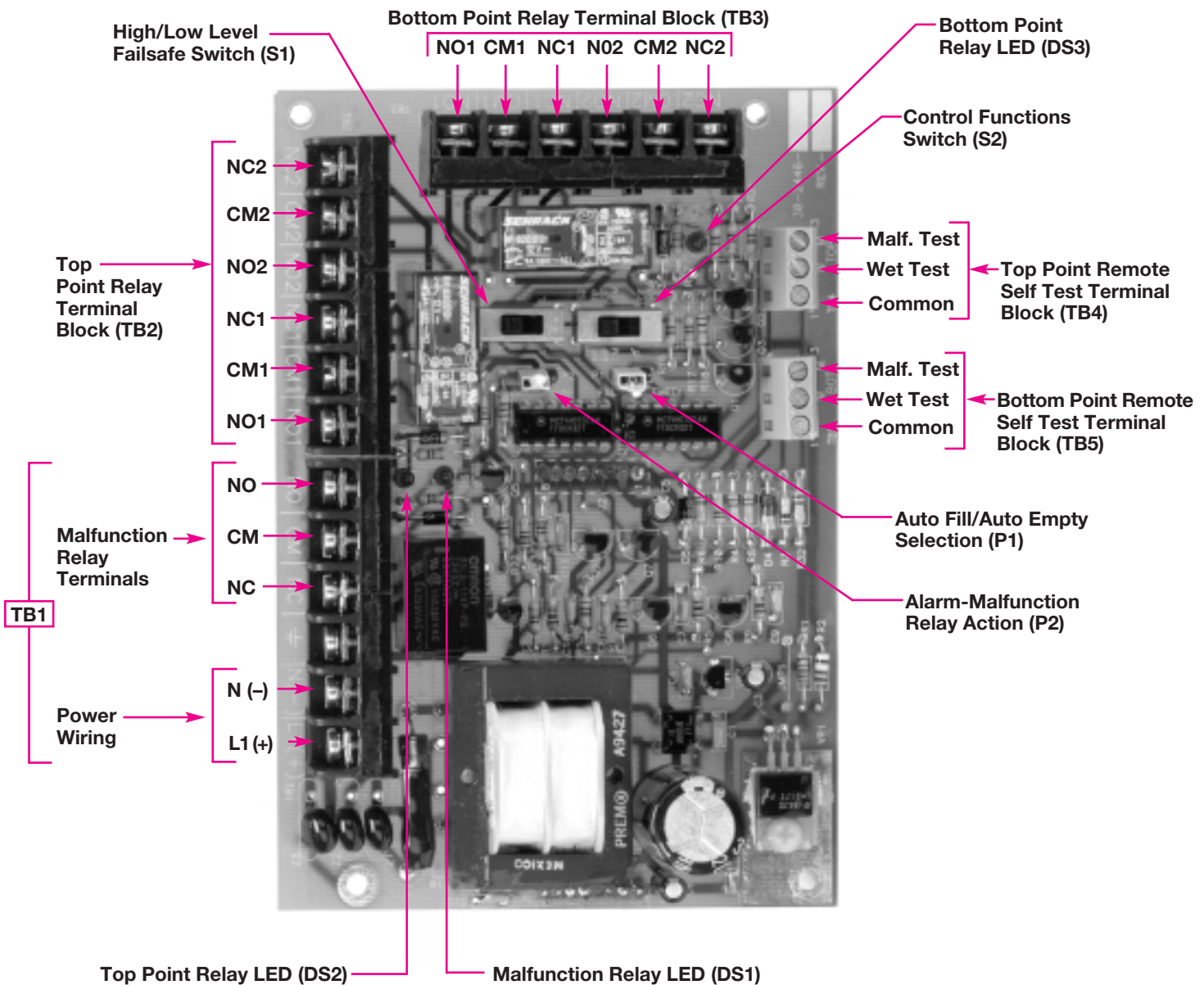

Figure 7  
92S Dual Point Relay Output 120/240 VAC Power Supply Board

# FOUR-WIRE MODELS

## INSTALLATION/WIRING cont.

### REMOTE ELECTRONICS INSTALLATION

Remote mounting must be used where high process temperatures prohibit integral mounting of the electronics. A remote electronics also allows more convenient servicing when the transducer is mounted at an inconvenient location.

1. Install electronics housing using the mounting bracket provided with order. Provide adequate clearance to remove housing cover.
2. Remove housing cover.

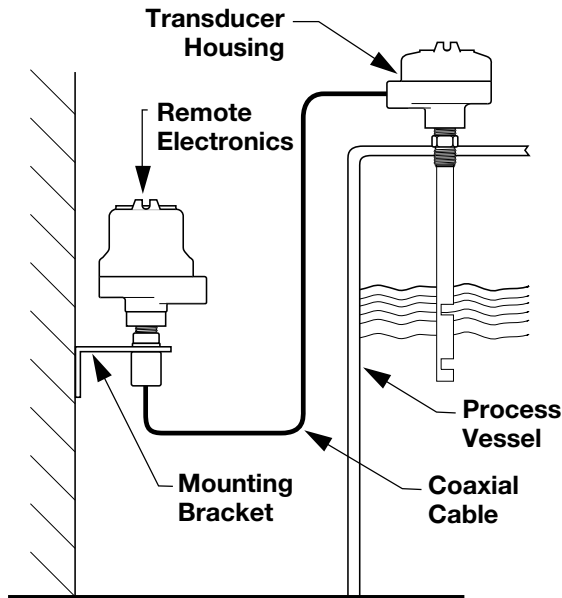

Figure 8  
Remote Installation

3. No. 14 AWG wire size is recommended for power and relay wiring.
4. Route power and relay wiring through side housing connection.
5. Run power leads to power terminal strip (TB1) on left side of the power supply board. Refer to Figure 4 on page 4.
6. Run relay leads to terminal block TB2. If an opto-isolated device is available, wire to the same contacts desired.
7. Run coaxial cable from transducer housing termination board through the bottom housing connection, as shown in Figure 8 above.
8. Plug coaxial cable into electronics as follows:  
Cables from OUT1 and OUT2 on transducer termination board (Figure 9) plug into J1 and J2 on the bottom amplifier board in any order. If this is a dual point design, cables from OUT1 and OUT2 on the transducer termination board plug into J1 and J2 (in any order) on amplifier board marked A. The cables from OUT3 and OUT4 plug into J1 and J2 (in any order), on amplifier board marked B.

### REMOTE ELECTRONICS INSTALLATION cont.

**CAUTION:** Do not interchange transducer connection cables (OUT1 & OUT2 with OUT3 & OUT4).

9. Dress wiring to ensure no interference or contact with cover or circuit board components.

**OBSERVE ALL APPLICABLE ELECTRICAL CODES AND PROPER WIRING PROCEDURES.**

10. Prevent moisture seepage into the enclosure by installing approved seal-drain fittings in the conduit run leading into the unit.
11. Replace housing cover.

**CAUTION:** In hazardous areas, do not power the unit until the conduit is sealed and the enclosure cover is screwed down securely.

### REMOTE TRANSDUCER INSTALLATION

1. Screw transducer into tank opening using pipe compound or thread tape. If flanged, bolt unit to mating flange with proper gasket.

**NOTE:** Refer to Coaxial Cable Installation section below before installing cables.

2. To prevent cable damage, DO NOT remove transducer from tank with coaxial cable connected to the amplifier.

**CAUTION:** Never tighten transducer to tank connection by turning housing. Use wrench on transducer mounting nut flats. Use thread tape or suitable pipe compound on threads. Do not over tighten.

# FOUR-WIRE MODELS INSTALLATION/WIRING cont.

## COAXIAL CABLE INSTALLATION

All 91S/92S remote units are equipped with a transducer housing, as shown in Figure 8.

The coaxial cables from the transducer will terminate inside the transducer housing in phono jacks. Connect phono jacks OUT1 and OUT2 on the remote terminal board to J1 and J2 on the main amplifier board. The dual point 92S will have an additional pair of cables terminating in OUT3 and OUT4 (Coaxial cable extensions must be run in conduit.) Refer to Figure 9 below.

**CAUTION:** To retain explosion proof/vapor proof rating, coaxial cable must be run in properly sealed conduit.

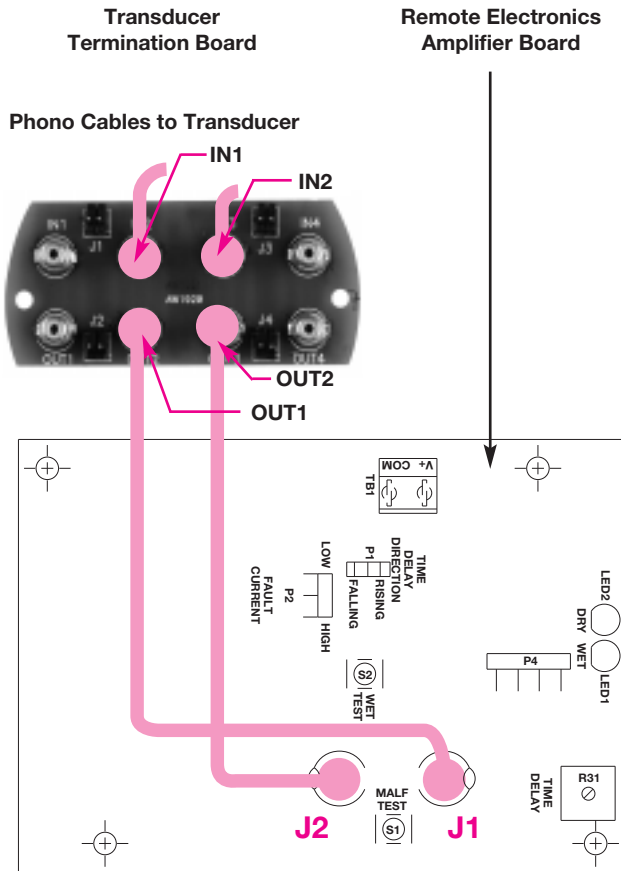

Figure 9

## DUAL POINT MODELS

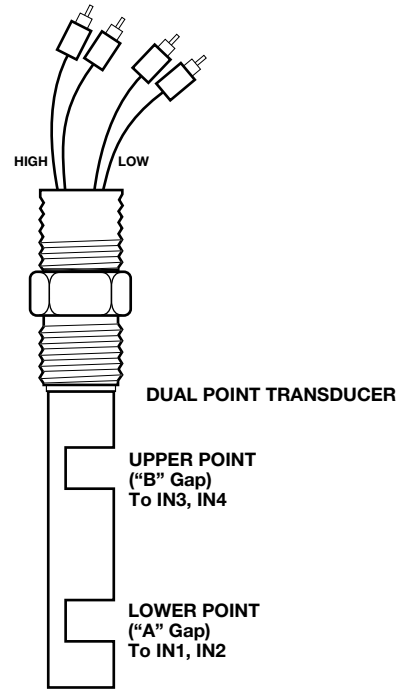

Figure 10

For integral mount units, cable pair tagged **LOW** is plugged into J1 and J2 on lower amplifier board. Pair tagged **HIGH** is plugged into J1 and J2 on upper amplifier board. For remote mount models, cables from OUT1 and OUT2 are plugged into J1 and J2 on lower amplifier board, and cables from OUT3 and OUT4 are plugged into upper amplifier board. Refer to Figure 10.

**FOR USER SELECTIONS AND OPERATIONAL TESTING, TURN TO PAGE 11.**

# ELECTROSTATIC DISCHARGE (ESD) HANDLING PROCEDURE

Magnetrol's electronic instruments are manufactured to the highest quality standards. These instruments utilize electronic components which may be damaged by static electricity present in most work environments. The following steps are recommended to reduce the risk of component failure due to electrostatic discharge:

1. Ship and store circuit boards in anti-static bags. If an anti-static bag is not available, wrap board in aluminum foil. Do not place boards on foam packing materials.

2. Use a grounding wrist strap when installing and removing circuit boards. A grounded workstation is also recommended.
3. Handle printed circuit boards only by the edges. Do not touch components or connector pins.
4. Ensure that all electrical connections are completely made and none are partial or floating. Ground all equipment to a good, earth ground.

## TWO-WIRE MODELS INSTALLATION/WIRING

All power and output connections are made at the two position terminal strip (TB1) on the amplifier board. 16-24 AWG twisted shielded pair wire is recommended.

**CAUTION:** Never tighten unit to the tank connection by turning the housing. Use a wrench on the transducer mounting nut flats. Use thread tape or suitable pipe compound on threads. Do not over tighten.

### OBSERVE ALL LOCAL ELECTRICAL CODES AND PROPER WIRING PROCEDURES.

1. Make sure the power source is turned off.
2. Unscrew and remove housing cover.
3. Pull power supply and control wires through conduit connection.
4. Connect power leads to proper terminals of TB1 on amplifier PC board as shown in Figure 11.

5. Select High/Low failsafe setting by placing jumper (P2) in desired position. For low level failsafe, position jumper between the middle pin and the pin next to the LOW mark on P2. For high level failsafe, position jumper between the middle pin and the pin next to the HIGH mark on P2. Refer to Figure 11.
6. For dual point 92S units, power each amplifier board from a separate power supply.
7. Dress wiring to guard against interference or contact with cover or circuit board components.
8. Prevent moisture seepage into housing by installing an approved seal-drain fitting in the conduit run leading to the unit.
9. Installation is complete. Replace housing cover.

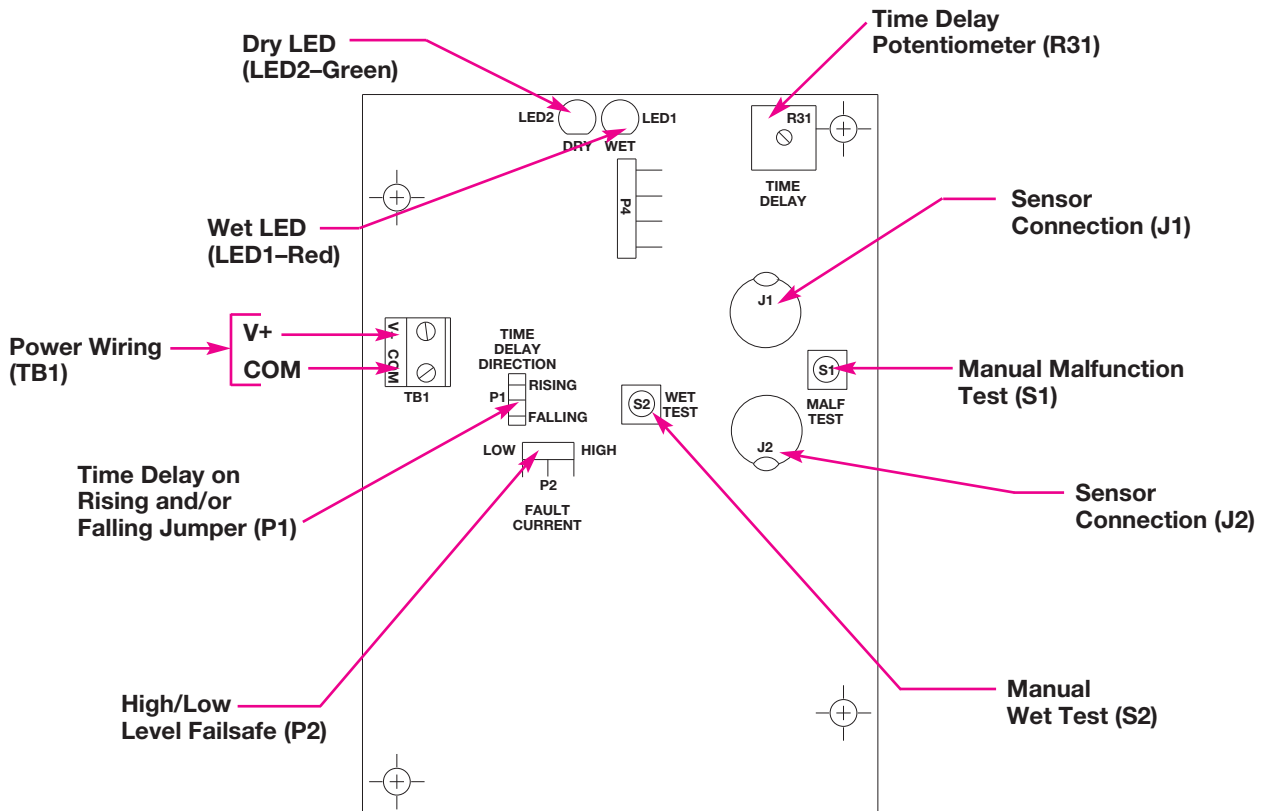

Figure 11  
Two-Wire 91S Amplifier Board

## TWO-WIRE MODELS INSTALLATION/WIRING cont.

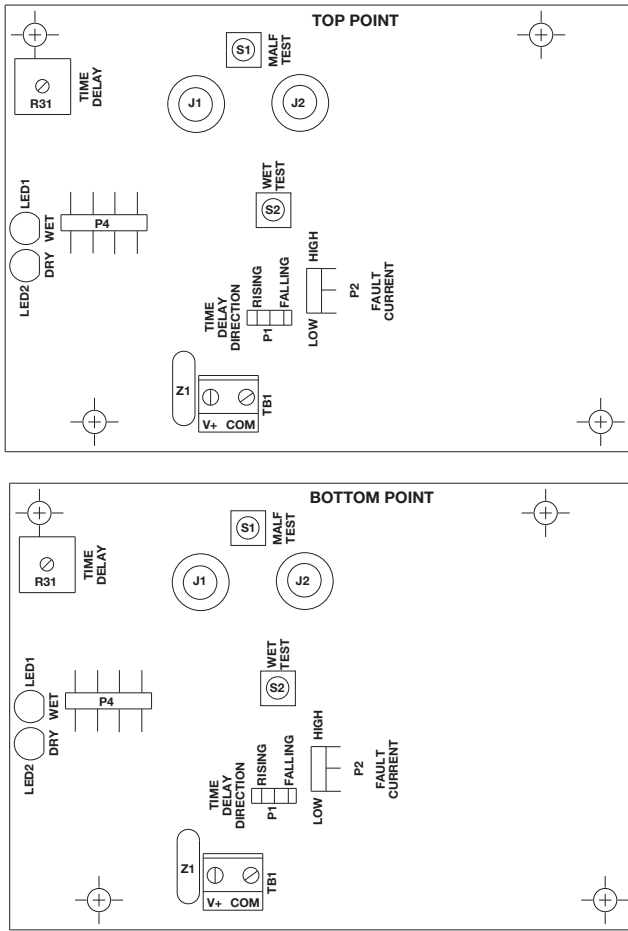

Figure 12  
Dual Point 92S Amplifier Boards

### REMOTE ELECTRONICS INSTALLATION

Remote electronics must be used where high process temperatures prohibit integral mounting of the electronics. A remote electronics also allows more convenient servicing when the transducer is mounted at an inconvenient location.

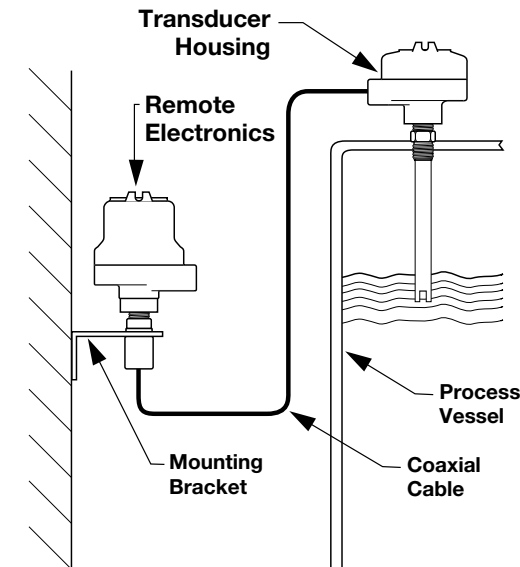

Figure 13  
Remote Installation

### REMOTE ELECTRONICS INSTALLATION cont.

1. Install electronics housing using mounting bracket. Provide adequate clearance to remove housing cover.
2. Remove housing cover.
3. No. 14 AWG wire size is recommended for power and control circuit wiring.
4. Route power and control circuit through side housing connection.
5. Run power leads to power terminal strip on left side of PC board. Refer to Figure 11 on page 9.
6. Run control circuit leads to terminal block TB1.
7. Run coaxial cable from transducer or remote transducer termination board through the bottom housing connection, as shown in Figure 13 below.
8. Plug coaxial cable into amplifier board as follows (for 91S): Cables from OUT1 and OUT2 on remote transducer termination board plug into J1 and J2 on the amplifier board in any order.
9. Dress wiring to ensure no interference or contact with cover or circuit board components.

**OBSERVE ALL APPLICABLE ELECTRICAL CODES AND PROPER WIRING PROCEDURES.**

**CAUTION:** In hazardous areas, do not power the unit until the conduit is sealed and the enclosure cover is screwed down securely.

10. Prevent moisture seepage into the enclosure by installing approved seal-drain fittings in the conduit run leading into the unit.
11. Replace housing cover.

### REMOTE TRANSDUCER INSTALLATION

1. Screw transducer into tank opening using pipe compound or thread tape. If flanged, bolt unit to mating flange with proper gasket.

**NOTE:** Refer to Coaxial Cable Installation section below before installing cables.

2. To prevent cable damage, DO NOT remove transducer from tank with coaxial cable connected to the amplifier.

**CAUTION:** Never tighten transducer to tank connection by turning housing. Use wrench on transducer mounting nut flats. Use thread tape or suitable pipe compound on threads. Do not over tighten.

### COAXIAL CABLE INSTALLATION

Transducers are furnished with dual coaxial cables, which must be run in conduit to the electronics.

The coaxial cables from the transducer are terminated inside the remote housing. The transducer cable will terminate in the remote housing at IN1 and IN2. The remote cable will connect at OUT1 and OUT2 in the remote housing and terminate at J1 and J2 on main electronics. (Coaxial cable extensions must be run in conduit.) Refer to Figure 9 on page 8.

**CAUTION:** To retain explosion proof/vapor proof rating, coaxial cable must be run in properly sealed conduit.

## AMPLIFIER BOARD USER SELECTION DESIGNATIONS

### WET LED (LED1)

An LED which illuminates **red** when liquid fills the sensor tip or gap.

### DRY LED (LED2)

An LED which illuminates **green** when air is in the sensor tip or gap.

### Time Delay Potentiometer (R31)

The adjustable time delay (R31) can be variable from 0.5 to 30 seconds. This can be used under turbulent conditions to reduce relay chattering.

### High/Low Level Failsafe (P2 Jumper)

The term failsafe denotes the position the relay contacts assume when power to the unit is lost. To set a high level failsafe (relay energized dry), place jumper between middle pin and (HIGH) pin on P2. To set low level failsafe (relay energized wet), place jumper between middle pin and (LOW) pin.

### Time Delay on Rising and/or Falling Jumper (P1)

The jumper (P1) can be set to delay on rising or to delay falling level. Setting in the (RISING) position adjusts the delay on a dry to wet transition with a fixed 0.5 second delay on a wet to dry transition. Set in the (FALLING) position adjusts the delay on a wet to dry transition with a fixed 0.5 second delay on a dry to wet transition. Totally removing jumper provides delay on rising and falling level.

## POWER SUPPLY BOARD USER SELECTION DESIGNATIONS

### Auto Fill/Auto Empty Selection (P1–Dual point)

A jumper which allows the selection of an automatic fill or automatic empty function.

### Control–Malfunction Relay Action (P2–Dual point)

A jumper which allows joint or independent actuation of the control and malfunction relay. Independent (IND) allows separate action of each relay while joint (JOINT) ties the control with malfunction together if either changes state.

### Top Point Relay LED (DS2)

An LED on the 92S power supply board which illuminates **red** when control relay tied to top point changes state.

### Bottom Point Relay LED (DS3)

An LED on the 92S power supply board which illuminates **red** when the control relay tied to the bottom point energizes.

### Malfunction Relay LED (91S–DS2, 92S–DS1)

An LED on the power supply illuminates **red** when the malfunction relay is energized, indicating a normal condition. In case of a failure, light will go off.

### Control Function Switch (92S–S2)

A three position switch which allows the user to select the control function of the dual point unit. Select from simple Bottom Point–Top Point operation, Control Function–Bottom Point, or Control Function–Top Point.

## POWER SUPPLY BOARD USER SELECTIONS

### RELAY WIRING

Model 91S/92S units have a number of different relay wiring options. The table below lists relay contact positions for all possible combinations of power failure, state of the transducer gap and failsafe switch position. Each user must decide, from consideration of the overall system, which combinations of the above constitutes failsafe and alarm conditions; and, select the appropriate relay wiring and failsafe positions.

**Relay Wiring Chart—91S only**

Sensor Gap Condition	Failsafe Jumper on Amplifier* (P2)	Failsafe Jumper on Power Supply* (P1)	Alarm Relay	Malfunction Relay
Wet	L	L	Energized	Energized
Dry	L	L	De-Energized	Energized
Malfunction	L	L	De-Energized	De-Energized
Wet	H	H	De-Energized	Energized
Dry	H	H	Energized	Energized
Malfunction	H	H	De-Energized	De-Energized

\* Failsafe jumper on amplifier should be kept in low position if it is a relay 91S.

### Selector switch definitions on power supply board—91S only

Designation	Function	Action
P1	High (H) or Low (L) level failsafe	Allows energized state of alarm relay to set for wet or dry condition. H = de-energized when wet L = de-energized when dry
P2*	Joint (J) or Independent (I) Malfunction	J = alarm relay will always de-energize with a malfunction. I = with a malfunction & failsafe jumper (I) in (H) position, alarm relay will energize (or remain energized if sensor was dry when malfunction was detected)

\* The malfunction relay always de-energizes on a fault detection.

### TIME DELAY

All Model 91S/92S units are provided with an adjustable time delay of approximately 0.5 to 30 seconds. The time delay potentiometer is on the upper right corner of the amplifier PC board and marked TIME DELAY. There is a jumper selector marked P1 on the amplifier board. This is the wet and/or dry time delay. The time delay can be made on rising and/or falling level. When the jumper is placed in the (RISING) position, there will be an adjustable delay on a dry to wet transition, with a fixed 0.5 second delay on wet to dry transition. When the jumper is set in the (FALLING) position, the delay will be on a wet to dry transition with a fixed delay of 0.5 seconds on a dry to wet transition. If no jumper is placed on the pins, the delay will be in both directions. Minimum time delay occurs with potentiometer adjustment fully counterclockwise. Increase time delay by turning clockwise. Refer to Figure 9 on page 8.

## USER SELECTIONS cont.

**REFER TO FIGURE 12 ON PAGE 10 FOR THE FOLLOWING CHARTS.**

### LED INDICATION (TWO-WIRE/AMPLIFIER BOARD)

	Function	Action
LED1	WET LED	Illuminates red when wet (16 mA)
LED2	DRY LED	Illuminates green when dry (8 mA)
P1	Time delay (0.5-30 sec.) for rising and/or falling level	(RISING) wet delay=adj. delay on a dry to wet transition (FALLING) dry delay=adj. delay on a wet to dry transition
P2*	High or low level malfunction mode	(HIGH) = 19 mA (LOW) = 5 mA

\* Disabled when used with relay/opto-isolated outputs.

### SELECTOR SWITCH DEFINITIONS FOR AMPLIFIER PC BOARD (RELAY OR TWO-WIRE UNIT)

	Function	Action
S1 (MALF TEST)	Malfunction test switch	Forces a malfunction condition when pressed
S2 (WET TEST)	Wet test switch	Forces a wet condition when pressed (sensor must be in dry gap state)
J1	Sensor connection 1	Provides connection to sensor
J2	Sensor connection 2	Provides connection to sensor

**REFER TO FIGURE 4 ON PAGE 4 FOR THE FOLLOWING CHARTS.**

### SINGLE POINT DESIGN POWER SUPPLY PC BOARD DESIGNATIONS

	Function	Action
DS1	Alarm relay LED	Illuminates red when relay is energized
DS2	Malfunction relay LED	Illuminates red when relay is energized
TB3	Remote manual self test	Allows a remote normally open test switch to be wired externally for manual self testing of unit

### DUAL POINT DESIGN

The 92S is a dual point design that can be used for simple two point alarming functions, auto fill or auto empty capability. Additionally, with the auto fill or auto empty function, a separate high or low level alarm contact closure can be obtained. Review the chart below for switch selections and jumper positioning.

### INDEPENDENT/JOINT RELAY OPERATION

Jumper at 'P2'	Function
Independent (IND)	Relays K2 and K3 operate independently of malfunction relay
Joint (JOINT)	Relays K2 and K3 de-energize when any malfunction occurs

**CF\*** = Control Function      **LL** = Low Level  
**TP** = Top Point                **NO** = Normally Open  
**BP** = Bottom Point           **NC** = Normally Close  
**HL** = High Level               **CM** = Common

\* CF = Either Auto Fill or Auto Empty functions

### AUTOMATIC FUNCTION

Jumper at 'P1'	Function
Fill	Auto fill function between two points
Empty	Auto empty function between two points

See page 15 for more information

### DUAL POINT, POWER SUPPLY BOARD DESIGNATIONS

	Function	Action
TB1	terminal block for line voltage & malfunction relay	power & malfunction connection
TB2	terminal block for top point or control function	alarm connection
TB3	terminal block for top or bottom point	alarm connection
TB4 & TB5 (top)/(bottom)	remote push to test for manual self test	external test switch
P1	auto fill-auto empty	designation of control function
P2	independent or joint	independent or joint alarm with malfunction relays
S1	High (H) or Low (L) level failsafe	power & malfunction indication H - de-energize wet L - de-energize dry
S2*	control function switch	BP-TP BP-CF TP-CF
DS1	malfunction alarm LED	illuminates red when energized
DS2	top point alarm LED	
DS3	bottom point LED alarm	

\* See corresponding chart

# USER SELECTIONS cont.

## SELECTION DESCRIPTION

The following tables illustrate the various control schemes available depending on the positions of the Failsafe switch (S1), Control Function switch (S2), and Auto Fill/Auto Empty jumper (P1).

### BOTTOM POINT/TOP POINT

#### (S1) LLFS — (P1) AUTO EMPTY — (S2) BP/TP

Function	TB2	TB3
Both gaps dry	off	off
bottom gap wet	off	on
top gap wet	on	on
top gap dry	off	on
bottom gap dry	off	off

#### (S1) HLFS — (P1) AUTO EMPTY — (S2) BP/TP

Function	TB2	TB3
Both gaps dry	on	on
bottom gap wet	on	off
top gap wet	off	off
top gap dry	on	off
bottom gap dry	on	on

#### (S1) LLFS — (P1) AUTO FILL — (S2) BP/TP

Function	TB2	TB3
Both gaps dry	off	off
bottom gap wet	off	on
top gap wet	on	on
top gap dry	off	on
bottom gap dry	off	off

#### (S1) HLFS — (P1) AUTO FILL — (S2) BP/TP

Function	TB2	TB3
Both gaps dry	on	on
bottom gap wet	on	off
top gap wet	off	off
top gap dry	on	off
bottom gap dry	on	on

### BOTTOM POINT/CONTROL FUNCTION

#### (S1) HLFS — (P1) AUTO EMPTY — (S2) BP/CF

Function	TB2	TB3
Both gaps dry	off	off
bottom gap wet	off	on
top gap wet	on	on
top gap dry	on	on
bottom gap dry	off	off

#### (S1) HLFS — (P1) AUTO EMPTY — (S2) BP/CF

Function	TB2	TB3
Both gaps dry	off	on
bottom gap wet	off	off
top gap wet	on	off
top gap dry	on	off
bottom gap dry	off	on

#### (S1) LLFS — (P1) AUTO FILL — (S2) BP/CF

Function	TB2	TB3
Both gaps dry	on	off
bottom gap wet	on	on
top gap wet	off	on
top gap dry	off	on
bottom gap dry	on	off

#### (S1) HLFS — (P1) AUTO FILL — (S2) BP/CF

Function	TB2	TB3
Both gaps dry	on	on
bottom gap wet	on	off
top gap wet	off	off
top gap dry	off	off
bottom gap dry	on	on

### TOP POINT/CONTROL FUNCTION

#### (S1) LLFS — (P1) AUTO EMPTY — (S2) TP/CF

Function	TB2	TB3
Both gaps dry	off	off
bottom gap wet	off	off
top gap wet	on	on
top gap dry	on	off
bottom gap dry	off	off

#### (S1) HLFS — (P1) AUTO EMPTY — (S2) TP/CF

Function	TB2	TB3
Both gaps dry	off	on
bottom gap wet	off	on
top gap wet	on	off
top gap dry	on	on
bottom gap dry	off	on

#### (S1) LLFS — (P1) AUTO FILL — (S2) TP/CF

Function	TB2	TB3
Both gaps dry	on	off
bottom gap wet	on	off
top gap wet	off	on
top gap dry	off	off
bottom gap dry	on	off

#### (S1) HLFS — (P1) AUTO FILL — (S2) TP/CF

Function	TB2	TB3
Both gaps dry	on	on
bottom gap wet	on	on
top gap wet	off	off
top gap dry	off	on
bottom gap dry	on	on

# ON DEMAND SELF-TEST (Integral or Remote Units)

## SELF-TEST

With the transducer properly connected to the electronics, check to ensure all cable connections are correct.

By pressing and holding the Wet Test Switch when the sensor is dry, a wet sensor condition will be simulated. This allows a manual self test of the system and a convenient method of verifying the time delay settings.

The Malfunction Test Switch immediately forces a malfunction condition when it is pressed. This is true whether the sensor is wet or dry. When the switch is released, the true condition will be indicated (if any dry to wet delay has been set, there will be a delay before a wet sensor will be indicated).

Setting the High/Low Malfunction current jumper (P2) on the amplifier board of two-wire units to the LOW position will cause a malfunction to force a loop current of 5 mA and extinguish both LEDs if a malfunction is detected. If this jumper is set to the HIGH position, both LEDs will illuminate and the loop current will be forced to 19 mA if a malfunction occurs.

**NOTE:** If this board is part of a relay output model 91S, this jumper must be placed in the L position for proper operation.

## REMOTE MANUAL SELF-TESTING

Self testing is accomplished automatically and continuously on the 91S/92S. Additionally, a manual self test operation can be performed on the amplifier board with S1 (malfunction) or S2 (wet) or can be wired into the terminal block of the power supply board (TB3) for 91S, or (TB4 & TB5) for 92S. An external push button switch may be connected to TB3 on the single point power supply board (refer to Figure 4) using a twisted pair to actuate a remote wet test or a malfunction test. The power source for this push button test is internal to the 91S/92S.

**NOTE:** Remote manual self-testing is available on all four-wire models. It is not offered on the two-wire models.

## OPTO-ISOLATED OUTPUT

An opto-isolator consists of a Light Emitting Diode (LED) and a phototransistor (refer to Figure 14). The phototransistor contains a light sensitive base that allows the transistor to conduct current only when it is exposed to light. The phototransistor provides a clean digital pulse, and since it is not directly connected (wired) to the LED, complete electrical isolation is achieved between the input and the output of the opto-isolator.

The opto-isolator is encased in a plastic/epoxy case, to prevent “stray” light from affecting the output. The output is floating, meaning that it can be referenced to anything (preventing ground potential differences). It is polarity sensitive and has limits on voltage and current like any other electronic component.

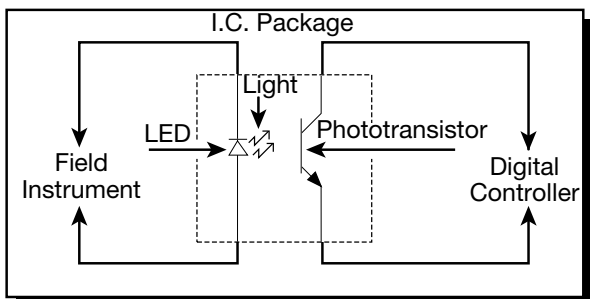

Figure 14

## OPTO-ISOLATED OUTPUT cont.

The opto-isolator will not eliminate the need for relay outputs. The relay is still the best electrical method for switching high current loads. The opto-isolator however, is a better solution for use with digital controllers.

The following illustrations depict methods for connecting the opto-isolator to a digital controller.

Figure 15 shows a configuration that allows for a “current-shift” output. The states are: 8 mA when the phototransistor is “open” and 16 mA when the phototransistor is closed.

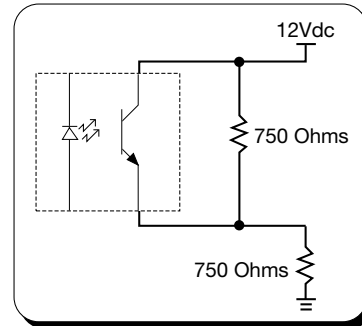

Figure 15

Figure 16 shows a configuration that allows for a “voltage-shift” output. The states are: 0 Vdc when the phototransistor is “open” and 5 Vdc when the phototransistor is closed. The output is taken across the 2.7K Ohm resistor.

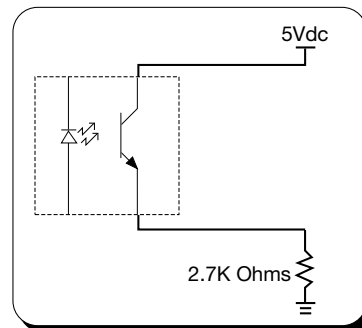

Figure 16

# TROUBLESHOOTING

**CAUTION:** In hazardous areas, do not remove housing until power is disconnected and atmosphere is determined to be safe.

## Sensor wetted, unit powered, but control relay does not energize.

1. Check terminals for loose connection.
2. Check coaxial cable jack plugs for improper seating or central wire rolled loose from pin.
3. Check coaxial cable for breaks, or signal wire shorted to ground shield.
4. Check the time delay—it should be fully counter-clockwise.

## Control output will not deactivate

1. Check transducer for plugged gap.
2. Make sure manual self test wiring is deactivated.
3. Check for dense foam or liquid in gap.

## No change in signal with level change.

1. Verify that the power wiring is properly connected and the correct voltage is applied. A minimum of 10 VDC is required at TB1 for loop powered two-wire units.
2. Check the control circuit wiring on models with relay or opto-isolator outputs.
3. Both the four-wire models and the two-wire models have status LEDs on the amplifier board. If only the green LED (LED2) is illuminated, a dry condition is indicated, while the red LED (LED1) alone indicates a wet condition.

## The 'WET' and 'MALFUNCTION' conditions may be simulated by pressing the associated test switches on the amplifier board. Set the time delay to its minimum (counterclockwise) value to facilitate testing.

4. If this model is other than a two-wire version, the power supply/relay board has LEDs that illuminate to indicate when the relays are energized. DS1 illuminates when the alarm relay is energized and DS2 on the power supply board illuminates when the malfunction relay is energized. Refer to the failsafe jumper table and verify that the relay action is correct.
5. If the manual self-test operations indicate that the system is operating properly but the output does not change when the liquid level passes the sensing point, check the sensor gap for any condition that may prevent liquid from contacting the sensor faces on rising level, or from draining from the gap on falling level.
6. Disconnect the control wiring and use a milliammeter to perform the following tests. Get a power supply to generate 1.5 to 8 Vdc; a 1.5 Vdc battery will suffice. Use Ohm's Law ( $R = E/I$ ) to calculate the resistance value necessary to limit the current to 15 mA with the voltage you are supplying. For example, if you supply a 9 Vdc battery, the resistance value would be 600 Ohms ( $9V/0.015 A = 600 \text{ Ohms}$ ). Build a series circuit with the power supply, the resistor, and the milliammeter. For the control opto-isolator, connect the circuit to the NO1 and CO1 terminals of TB2. For the malfunction opto-isolator, connect the circuit to terminals NO and CO of TB1; this has created a circuit loop. With the sensor in the liquid and the HLFS/LLFS switch in the HLFS position, the milliammeter should read 15 mA. Remove the sensing element from the liquid. The milliammeter should read approximately 0 mA.

Optionally, you can substitute a LED for the milliammeter. With the sensor in the liquid the LED will turn on.

# SPECIFICATIONS & AGENCY APPROVALS

## ELECTRICAL SPECIFICATIONS

### Two-Wire 91S/92S

Description	Specification
Supply voltage	10-35 VDC
Current loop loads	650 Ohms with 24 VDC power source 1200 Ohms with 35 VDC power source
Analog output	8 mA (dry) or 16 mA (wet) – 5 mA or 19 mA for fault conditions
Self-test (Automatic and Manual)	Continuous: Verifies operation of electronics, transducer, and crystal bond integrity. Also, a local on-demand self-test to force a malfunction condition.
Time delay	Variable potentiometer 0.5-30 seconds on rising and/or falling level
Failsafe	Field selectable–high or low level
Repeatability	±0.078" (1.98 mm)
Power consumption	1 watt maximum
Electronics temperature	–40° F to +160° F (–40° C to +71° C)
Transducer temperature	–40° F to +325° F (–40° C to +163° C)
Pressure (operational)	1500 PSIG @ –40° F to +325° F (103 BAR @ –40° C to +163° C)

### Four-wire 91S/92S

Description	Specification
Supply voltage	12 or 24 VDC 120 or 240 VAC, 50/60 Hz
Outputs	Two relay outputs. One or two control alarm relay(s)* rated at 10 Amp DPDT gold flash contacts and one malfunction or self-test fault relay rated at 10 Amp SPDT. Independent or joint interaction on the two relays via a field selectable jumper.
Self-test (Automatic and Manual)	Continuous: Verifies operation of electronics, transducer, and crystal bond integrity. Also, a local on-demand self-test to force a malfunction condition.
Time delay	Variable potentiometer 0.5-30 seconds on rising and/or falling level
Failsafe	Field selectable–High or Low level
Repeatability	±0.078" (1.98 mm)
Power consumption	2.50 VA nominal
Electronics temperature	–40° F to +160° F (–40° C to +71° C)
Transducer temperature	–40° F to +325° F (–40° C to +163° C)
Pressure (operational)	1500 PSIG @ –40° F to +325° F (103 BAR @ –40° C to +163° C)

## AGENCY APPROVALS

Agency	Model	Approval
FM	9XS-X1XX-E1X -F1X -Y1X with 9XX-XXX1-XXX	Explosion Proof Class I, Div. 1, Groups C & D Class II, Div. 1, Groups E, F, & G Class III, NEMA 4X, IP65
	9XS-X1XX-71X with 9XX-XXX1-XXX	Explosion Proof Class I, Div. 1, Groups B, C, & D Class II, Div. 1, Groups E, F, & G Class III, NEMA 4X, IP65
	9XS-XXXX-X1X with 9XX-XXX1-XXX	Non-Incendive Class I, Div. 2, Groups A, B, C & D NEMA 4X
CSA	9XS-X1XX-E1X -F1X -Y1X with 9XX-XXX1-XXX	Explosion Proof Class I, Div.1, Groups C & D Class II, Div. 1, Groups E, F, & G Class III, Type 4X
	9XS-X1XX-71X with 9XX-XXX1-XXX	Explosion Proof Class I, Div. 1, Groups B, C, & D* Class II, Div. 1, Groups E, F, & G Class III, Type 4X
	9XS-XXXX-X1X with 9XX-XXX1-XXX	Non-Incendive Class I, Div.2, Groups A, B, C & D Class II, Div. 2, Groups F, & G Class III, Type 4X
GENELEC	91S-X1XX-X1X with 9XX-XXX1-XXX	EEx d II C T6

\* For CSA – remote probe only approved for Class I, Div.1, Groups C & D

These units have been tested to EN 50081-2 and EN 50082-2 and are in compliance with the EMC Directive 89/336/EEC.

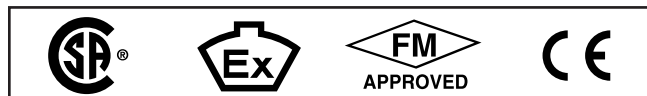

\* One control = single point  
Two control = dual point

## PRESSURE AND TEMPERATURE RATINGS

Transducer	Operating / Non-Operating Pressure		Temperature
	PSIG	BAR	
316 SS/ 316 SS Ti	1500	103	–40° F to +325° F (–40° C to +163° C)
Hastelloy C	1500	103	–40° F to +325° F (–40° C to +163° C)
Monel	1500	103	–40° F to +325° F (–40° C to +163° C)

# SPECIFICATIONS

## DIMENSIONAL SPECIFICATIONS inches (mm)

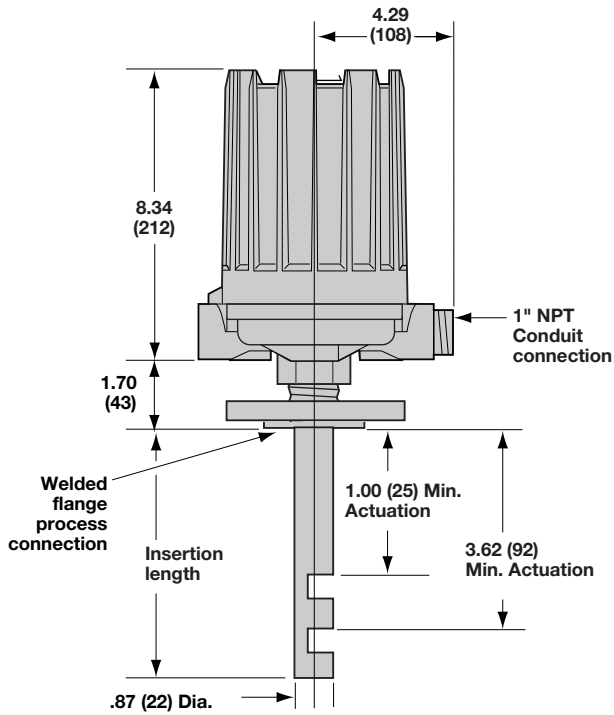

**Figure 17**  
Integral Group B NEMA 4X/7/9 Housing  
(9XS-XXXX-710 Models)

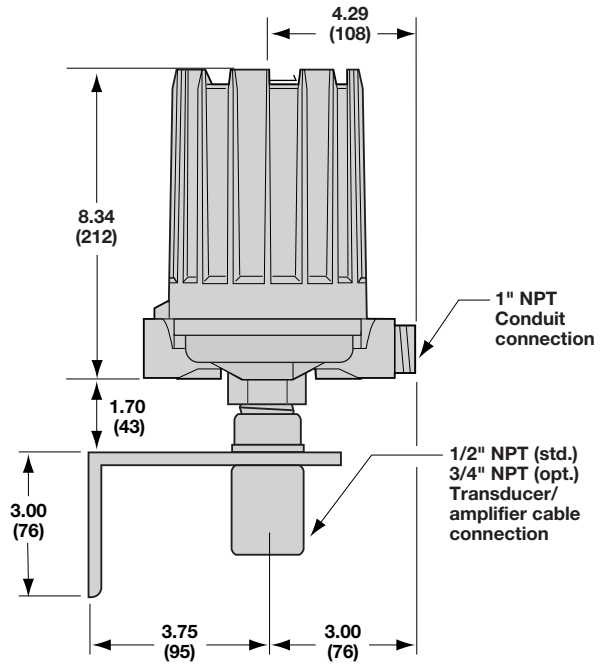

**Figure 18**  
Remote Group B, NEMA 4X/7/9,  
(9XS-XXXX-711 Models)

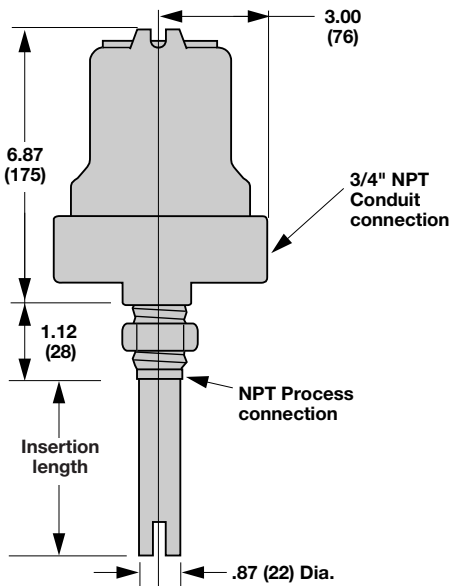

**Figure 19**  
91S-XXXX-F10 Models  
(w/ Tip Sensitive 316 SS Transducer)

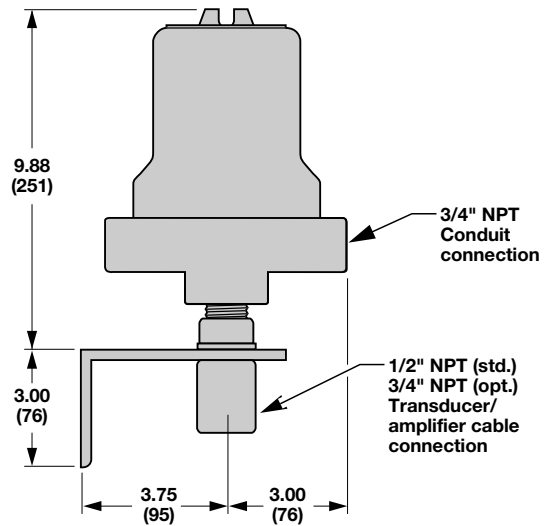

**Figure 20**  
91S-XXXX-F11 Models

# SPECIFICATIONS cont.

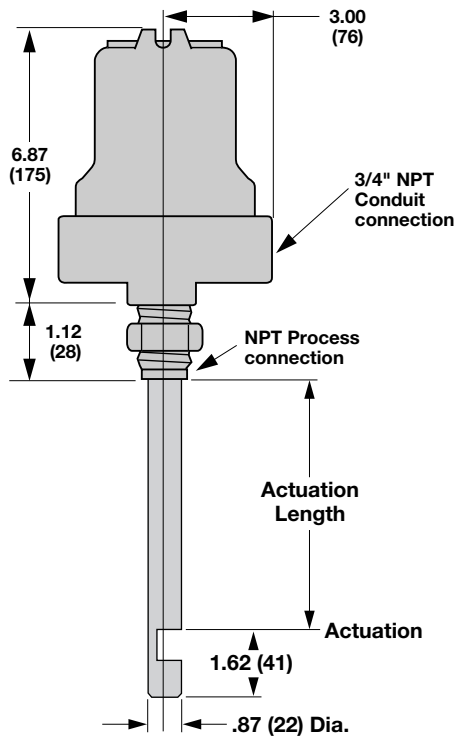

Figure 21

91S-XXXX-F10 (w/ Side Gap Monel or HC Transducers)

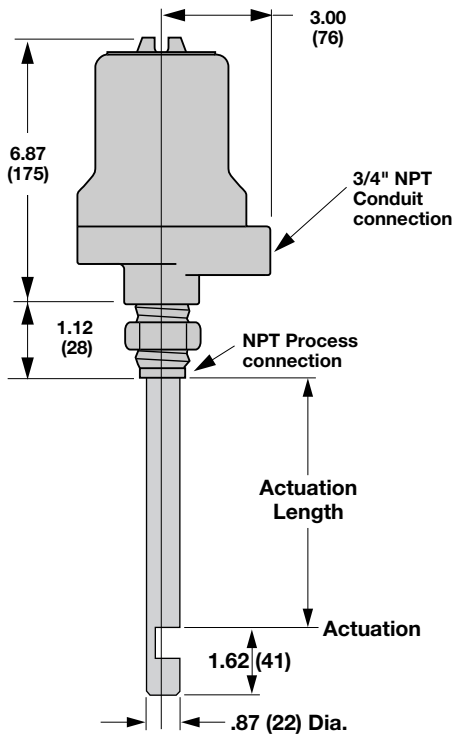

Figure 23

91S-XXXX-E10 (w/ Side Gap Monel or HC Transducers)

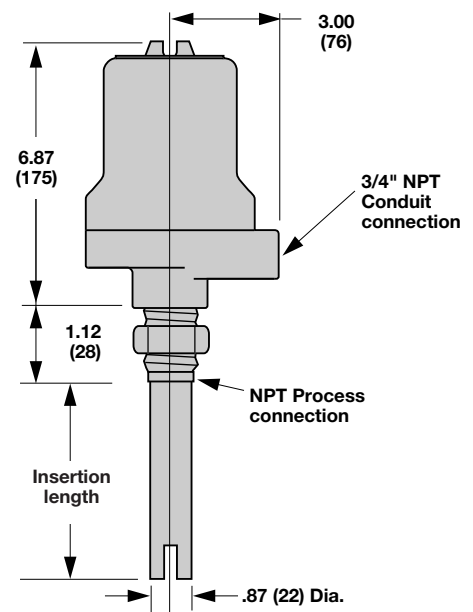

Figure 22

91S-XXXX-E10 Models  
(w/ Tip Sensitive 316 SS Transducer)

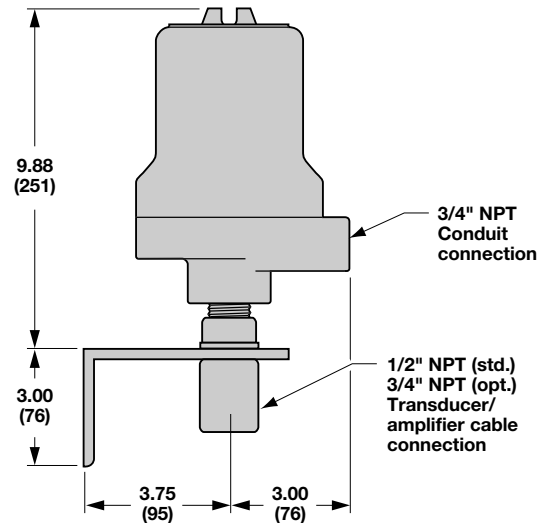

Figure 24  
(91S-XXXX-E11 Models)

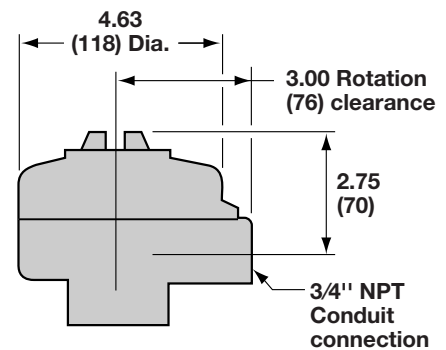

Figure 25  
Remote Transducer Housing

# REPLACEMENT PARTS

No.	Description	Part Number				
		120 VAC	240 VAC	24VDC	12VDC	
1*	Amplifier Board	Single Pt. Relay	030-2184-003			
		Dual Pt. Relay	Master (Top)	030-2184-003		
			Slave (Bottom)	030-2184-004		
		Single—two-wire	030-2184-001			
		Dual—two-wire	Master (Top)	030-2184-001		
Slave (Bottom)	030-2184-002					
2*	Single Point Power Supply PC Board	10 Amp DPDT	030-2445-001	030-2445-003	030-2445-007	030-2445-005
		Opto-Isolated	030-2445-002	030-2445-004	030-2445-008	030-2445-006
3*	Dual Point Power Supply PC Board	10 Amp DPDT	030-2446-001	030-2446-002	030-2446-004	030-2446-003
		Opto-Isolated	030-2446-006	030-2446-007	030-2446-008	030-2446-009
4	Housing Cover	NEMA 4X/7/9, Aluminum sand cast	002-6204-600			
		NEMA 4X/7/9, Aluminum die cast Group B	004-9174-007			
		NEMA 4X/7/9, 316 Stainless steel	002-6204-605			
5	Cover Seal	O-Ring				
6	Housing Base	NEMA 4X/7/9, Aluminum sand cast, Single conduit (3/4" NPT)	004-9104-003			
		NEMA 4X/7/9, Aluminum sand cast, Double conduit (3/4" NPT)	004-9182-003			
		Aluminum die cast, Double conduit, (1" NPT)	004-9173-008			
		NEMA 4X/7/9, 316 Stainless steel Single conduit, (3/4" NPT)	004-9140-002			
7	Remote Transducer Housing	Aluminum sand or die cast	004-9105-001			
		316 Stainless steel	004-9142-001			
8	Remote Cover Seal	O-Ring				
9	Remote Transducer Base	Aluminum sand cast, Single conduit, (3/4" NPT)	004-9104-001			
		316 Stainless steel, Single conduit, (3/4" NPT)	004-9140-001			
10	Remote Transducer Termination Board Bracket	Mounting bracket				
11*	Transducer Termination Board	Remote PCB				
12	Remote Electronics Mounting Bracket	Mounting bracket (1/2" NPT)				
13	Coaxial Cable**	RG 178 (1 to 50 feet)	037-3155-XXX			
		RG 58 (51 to 300 feet)	037-3156-XXX			

\* Refer to ESD Handling Procedure on page 4.

\*\* Two pairs for dual point.

**WARNING:** Explosion hazard — Substitution of components may impair suitability for hazardous locations.

**WARNING:** Explosion hazard — Do not disconnect equipment unless power has been switched off, or the area is known to be nonhazardous.

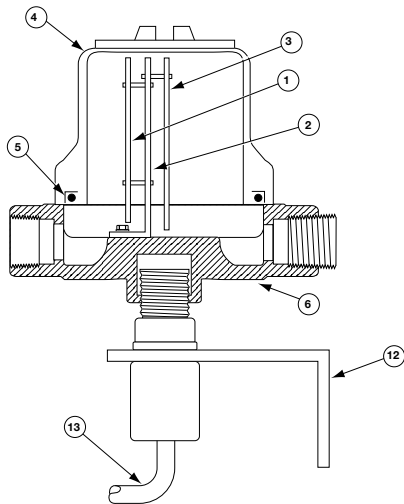

Figure 26

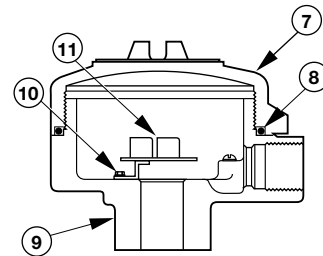

Figure 27

### Transducer replacement parts

- 1a. Order the 9X1 Transducer model number from the unit's name-plate.
- 1b. Construct part number from Transducer Part Number section under Model Identification from pages 1 or 2.



Figure 28

# IMPORTANT

## PRODUCT WARRANTY

All Magnetrol/STI electronic and ultrasonic level and flow controls are warranted free of defects in materials or workmanship for one full year from the date of original factory shipment.

If returned within the warranty period; and, upon factory inspection of the control, the cause of the claim is determined to be covered under the warranty; then, Magnetrol/STI will repair or replace the control at no cost to the purchaser (or owner) other than transportation.

Magnetrol/STI shall not be liable for misapplication, labor claims, direct or consequential damage or expense arising from the installation or use of equipment. There are no other warranties expressed or implied, except special written warranties covering some Magnetrol/STI products.

## QUALITY ASSURANCE

The quality assurance system in place at Magnetrol/STI guarantees the highest level of quality throughout the company. Magnetrol/STI is committed to providing full customer satisfaction both in quality products and quality service.



Magnetrol's quality assurance system is registered to ISO 9001 and Z299.1 affirming its commitment to known international quality standards providing the strongest assurance of product/service quality available.

## ASSURED QUALITY & SERVICE COST LESS

### SERVICE POLICY

Owners of Magnetrol/STI controls may request the return of a control or any part of a control for complete rebuilding or replacement. They will be rebuilt or replaced promptly. Controls returned under our service policy must be returned by Prepaid transportation. Magnetrol/STI will repair or replace the control at no cost to the purchaser (or owner) other than transportation if:

- Returned within the warranty period; and
- The factory inspection finds the cause of the claim to be covered under the warranty.

If the trouble is the result of conditions beyond our control; or, is NOT covered by the warranty, there will be charges for labor and the parts required to rebuild or replace the equipment.

In some cases it may be expedient to ship replacement parts; or, in extreme cases a complete new control, to replace the original equipment before it is returned. If this is desired, notify the factory of both the model and serial numbers of the control to be replaced. In such cases, credit for the materials returned will be determined on the basis of the applicability of our warranty.

No claims for misapplication, labor, direct or consequential damage will be allowed.

### LOW VOLTAGE DIRECTIVE

For use in Category II installations. If equipment is used in a manner not specified by manufacturer, protection provided by equipment may be impaired.

### RETURN MATERIAL PROCEDURE

So that we may efficiently process any materials that are returned, it is essential that a "Return Material Authorization" (RMA) number be obtained from the factory, prior to the material's return. This is available through Magnetrol/STI's local representative or by contacting the factory. Please supply the following information:

- Company Name
- Description of Material
- Serial Number
- Reason for Return
- Application

Any unit that was used in a process must be properly cleaned in accordance with OSHA standards, before it is returned to the factory.

A Material Safety Data Sheet (MSDS) must accompany material that was used in any media.

All shipments returned to the factory must be by prepaid transportation.

All replacements will be shipped F.O.B. factory.

**Note:** Refer to ESD Handling Procedure on page 4.



a subsidiary of Magnetrol International, Incorporated

5300 Belmont Road • Downers Grove, Illinois 60515-4499 • 630-969-4028 • Fax 630-969-9489



5300 Belmont Road • Downers Grove, Illinois 60515-4499 • 630-969-4000 • Fax 630-969-9489 • Website <http://www.magnetrol.com>  
6291 Dorman Road • Mississauga, Ontario L4V-1H2 • 905-678-2720 • Fax 905-678-7407  
Heikenstraat 6 • B 9240 Zele, Belgium • 052 45.11.11 • Telex 25944 • Fax 052 45.09.93  
Regent Business Ctr., Jubilee Rd. • Burgess Hill, Sussex RH15 9TL U.K. • 01444-871313 • Fax 01444-871317

©1998 Magnetrol International, Incorporated. All rights reserved. Printed in the USA.  
Magnetrol and Magnetrol logotype are registered trademarks of Magnetrol International.

Performance specifications are effective with date of issue and are subject to change without notice.  
The brand and product names contained within this document are trademarks or registered trademarks of their respective holders.

**BULLETIN: 51-623.2**  
**EFFECTIVE: May 1998**  
**SUPERSEDES: January 1997**