



# Thermatel® Model TA1 Mass Flow Transmitter

## DESCRIPTION

---

Thermatel Thermal Mass Flow Transmitter, Model TA1, provides a high level of performance in mass flow measurement of air and gases. Powerful microprocessor-based electronics provides an instrument that is easy to set up and configure. The TA1 provides the highest level of accuracy, repeatability, and temperature compensation available.

## TECHNOLOGY FEATURES

---

- Direct mass flow measurement
- High turndown ratios
- Excellent low flow sensitivity
- Low pressure drop

## ELECTRONICS FEATURES

---

- Integral key pad and display on the front panel; no need to open enclosure
- NEMA 4X and Class I, Division 2 rating for the main electronics
- Two-line, 16 digits per line alphanumeric display of all parameters
- Two 4–20 mA output signals (one for mass flow rate; one for temperature); each is independently configured
- Each 4–20 mA loop can be set up for active or passive operation
- RS-485/Modbus digital communication
- Advanced diagnostics check the probe and wiring, plus perform routine self-test
- Displays velocity, temperature, flow rate, and totalized flow
- Cable lengths up to 250 feet (76 m)
- Resettable software totalizer



## PROBE FEATURES

---

- All 316L welded stainless steel construction
- Optional Hastelloy C construction
- Selection of process connections, including threads, welded flange construction, and use with compression fitting
- Hot tap optional
- Explosion proof probe and wiring housing
- Process temperatures up to +400° F (+200° C)
- NIST traceable test bench provides accurate calibration

## APPLICATIONS

---

- Combustion air
- Compressed air
- Natural gas
- Aeration lines
- Digester gas
- Vent lines/flare headers
- Hydrogen piping

## TECHNOLOGY

---

Thermatel flow transmitter Model TA1 measures mass flow by detecting heat dissipation from a heated surface. The sensor contains two mass balanced elements with precision matched RTDs. The reference RTD measures the process temperature; the active RTD measures the temperature of the heated element. The temperature difference between the two RTDs is greatest at low flow and decreases in a non-linear relationship as the flow increases. The instrument accurately measures this temperature differential and converts it to a linear flow signal

with a 100-to-1 turndown.

The microprocessor-based electronics provide the ability to configure the instrument for your exact process conditions, provide advanced diagnostics, plus advanced temperature compensation program to ensure accurate, repeatable flow measurement over the entire operating range of the instrument.

The TA1 is available with either an insertion probe or flow body.

## FLOW BODY FEATURES

---

- ½" to 4" pipe sizes
- NPT threads available up to 2" in size
- Stainless steel and carbon steel (with stainless steel sensor) construction
- Flange connections for all sizes
- Optional stainless steel flow conditioning plate for 1.5" and higher
- Flow conditioning for ½" to 1" based on upstream length and sensor design

## ADDITIONAL FEATURES

---

### PROBE INSTALLATION

Probes can be provided with a variety of process connections, including threads, flanges, or installation through a compression fitting. The sensor will fit pipe sizes of ½" diameter or larger (2" minimum with thread connection).

The sensor is protected to prevent damage due to "bottoming-out" if inserted too far into a pipe.

When using an insertion probe with compression fitting, the user can adjust the position of the sensor in the pipe to obtain the optimum location. Typically, this will be with the bottom of the probe 1.0" lower than the center line of the pipe.

### TOTALIZER

The software totalizer provides an eight-digit display of the most significant numbers in the user's choice of engineering units. If the totalized display exceeds eight digits, then the display changes to exponential notation. The use of EEPROM for storage of totalized data eliminates the need for backup batteries and provides maximum safeguard of data in the event of a power interruption. The totalizer can be reset via software.

### TEMPERATURE COMPENSATION

Thermal flow technology measures the mass flow rate without the need for pressure and temperature correction. However, there is a need to temperature compensate the mass flow measurement for changes in gas properties due to variations in process temperature. By measuring the gas temperature, Model TA1 provides advanced temperature compensation to correct for changes in properties of the gas. The TA1 provides accurate flow measurement over the entire specified temperature range of the instrument.

### AREA COMPENSATION FOR PIPE SIZE

Insertion of the sensor into a pipe reduces the flow area, thus increasing the velocity for a given flow rate. Magnetrol's TA1 automatically compensates the flow measurement based on actual area of the pipe. The user simply enters the size or the area of the pipe, and the instrument automatically compensates the flow measurement.

### AIR EQUIVALENCY

Using historic air-gas calibration data, an air equivalency calibration can be performed on select gases. Consult Magnetrol for details and flow ranges.

## ADDITIONAL FEATURES

---

### TURNDOWN

The TA1 offers excellent low flow sensitivity and high turndown ratios. The minimum detectable mass velocity is 25 SFPM. This provides high turndown ratios of over 100 to 1, depending upon the maximum flow rate.

### SELECTABLE STP CONDITIONS

The TA1 directly measures mass flow of the gas at standard pressure and temperature (STP) conditions. Software permits the user to change STP conditions for their own requirements.

## SPECIFICATIONS

---

### PERFORMANCE

Description	Specification
Flow range maximum	25–40,000 SFPM (0.15-175 Nm/s) air reference to standard conditions. Higher ranges and other gases available; contact factory.
Flow range minimum	25–500 SFPM (0.15–2.5 Nm/s) air reference to standard conditions.
Accuracy flow	±1% of reading +0.5% of calibrated full scale
Accuracy temperature	±2° F (1° C)
Repeatability	±0.5% of reading
Linearity	Included in flow accuracy
Temperature effect	±0.05%/° C
Turn down	100:1 typical (depending on calibrated flow range)
Calibration	NIST traceable
Ambient temperature	
Electronics	Without heater and thermostat: -4° to +160° F (-20° to +70° C) With heater and thermostat: -40° to +160° F (-40° to +70° C)
Display	Two-line alphanumeric, LCD 16-characters per line
Keypad	16-button integral to front panel
Humidity (electronics)	99% Non-condensing
Cable length	250 feet (76 m) (consult factory for longer lengths)
Supply voltage	120 VAC, 50–60 Hz, +10%/-15% 240 VAC, 50–60 Hz, +10%/-15% 24 VDC ±20%
Power consumption	12 watts maximum/15 VA maximum with heater option 62 watts maximum/65 VA maximum
Analog output signal	
Active	4–20 mA flow (isolated) maximum 1000 Ω loop resistance 4–20 mA temperature (isolated) maximum 1000 Ω loop resistance
Passive	4–20 mA flow (isolated) loop resistance dependent on power supply 4–20 mA temperature (isolated) loop resistant dependent on power supply
Diagnostic alarm	3.6 mA, 22 mA, HOLD
Digital output	RS-485/Modbus, RTU mode
Relays (optional)	0, 2, or 4 10-amp SPDT resistive with gold flash contacts
Fail-safe	Software selectable

# SPECIFICATIONS

## PROBE



Materials	316L stainless steel all welded, Hastelloy C-276 optional
Process connections	Refer to model number
Pressure rating	1500 psig @ +70° F (103 bar @ +20° C), 1375 psig @ +400° F (95 bar @ +200° C)
Temperature rating	-50° to +400° F (-45° to +200° C)

## FLOW BODY

Materials	316/316L stainless steel all welded Carbon steel with stainless steel sensor
Process connections	NPT or 150 lb. flange – Refer to model number
Pressure rating	1500 psig @ +70° F (103 bar @ +20° C), 1100 psig @ +400° F (79 bar @ +200° C) dependent upon process connections
Temperature rating	-50° to +400° F (-45° to +200° C)①

① For operating temperatures between +250° F and +400° F (+120° C and +200° C), either use remote electronics or a longer length insertion probe to provide an additional four inches (100 mm) between the electronics and the compression fitting.

# AGENCY APPROVALS

AGENCY	APPROVED MODEL	PROTECTION METHOD	AREA CLASSIFICATION
 <b>FM</b> APPROVED	TA1-X2XX-1XX	Hazardous environments  Indoors and outdoors	Class I, Div 2, Groups A, B, C & D, T4A Class II, Div 2, Groups F & G Class III NEMA 4X and IP 65
	TXR-XXX0-XXX (probe) TFT-XXXX-000 (flow body)	Hazardous environments  Indoors and outdoors	Class I, Div 1, Groups B, C & D Class II, Div 1, Groups E, F & G Class III (Maximum surface temperature of probe is 73° C above process temperature) NEMA 4X and IP 65
 <b>CSA</b>	TA1-X2XX-11X	Suitable for:  Indoors and outdoors	Class I, Div 2, Groups A, B, C & D, T4A Class II, Div 2, Groups E, F & G Class III Type 4X
	TXR-XXX0-XXX (probe) TFT-XXXX-000 (flow body)	Hazardous environments  Indoors and outdoors	Class I, Div 1, Groups C & D Class II, Div 1, Groups E, F & G Class III (Maximum surface temperature of probe is 73° C above process temperature) Type 4X

ATEX approved units available.  
Contact Magnetrol for selection.



These units have been tested to EN 61326 and are in compliance with the EMC Directive 89/336/EEC.

# RETRACTABLE PROBE ASSEMBLY

## HOT TAP

Magnetrol offers two methods of removing the probe from the pipe without having to shut down the process. The Hot Tap Retractable Probe Assembly is designed to meet API (American Petroleum Institute) standards. The less demanding valve with compression fitting (part 089-5218-001) will have some minor leakage when the probe is removed or re-inserted and does not have the safety cable to prevent “blow out” of the probe when removed under pressure. RPA requires a probe with 3/4" NPT process connection.

The valve with compression fitting uses a 1" NPT connection while the RPA uses a 1 1/2" NPT connection.



High Pressure



Low Pressure

089-5218-001

### BASIC MODEL NUMBER

RPA	RPA (Retractable Probe Assembly)
-----	----------------------------------

#### DESIGN TYPE

5	Low pressure (up to 50 psi), length in tenths of an inch
6	High pressure (up to 300# class service), length in tenths of an inch
E	Low pressure (up to 50 psi), length in centimeters
F	High pressure (up to 300# class service), length in centimeters

#### MATERIALS OF CONSTRUCTION

1	Carbon steel (high pressure design only, seal gland is 316 stainless steel)
4	316 stainless steel

#### PROCESS CONNECTION

0	1 1/2" NPT
1	1 1/2" 150 lb. flange
2	1 1/2" 300 lb. flange

#### BALL VALVE

0	No ball valve supplied
1	Carbon steel
2	Stainless steel

#### PROBE LENGTH

10 to 99.9 inches (example: 8.5" = 085)
7 to 253 centimeters (example: 18 cm = 018)

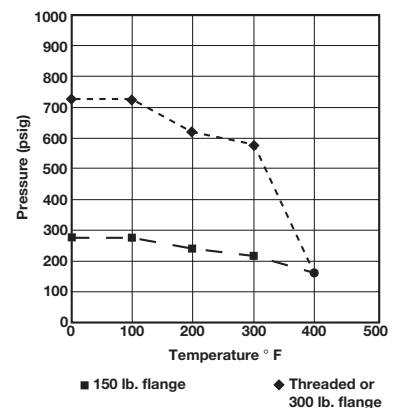

# DIMENSIONAL SPECIFICATIONS

INCHES ( m m )

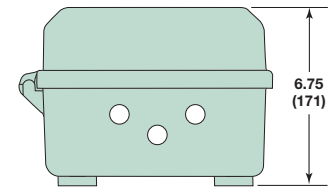
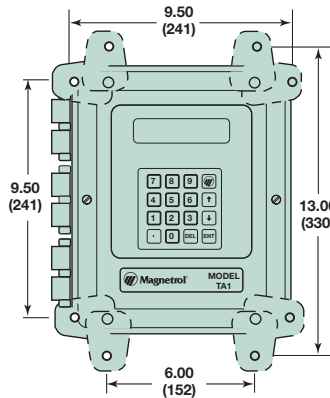
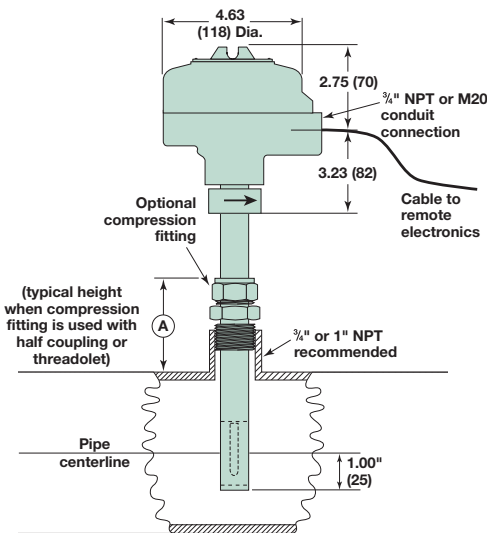

Remote electronics

Process Connection size	Height A	Compression fitting	
		Teflon ferrules	Stainless steel ferrules
1" NPT	3.1 (79)	011-4719-009 (100 psi maximum)	011-4719-007 (1500 psi maximum)
3/4" NPT	2.6 (66)	011-4719-008 (100 psi maximum)	011-4719-006 (1500 psi maximum)

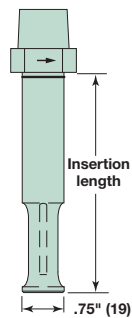

Insertion probe

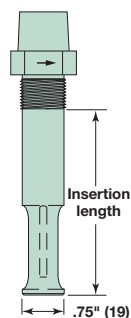

Probe w/NPT threads

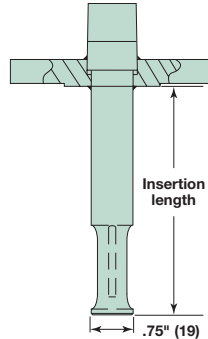

Flanged probe

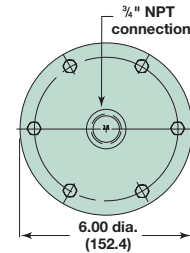

Duct mounting bracket with 3/4" NPT  
Part Number 089-7247-001 or  
089-7247-002 (includes hardware)

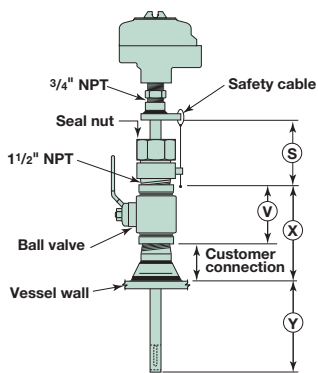

**Low Pressure Hot Tap**  
minimum probe length  
 $= S + X + Y$

S Dimension	
Threaded connection	4.0
Flanged connection	5.0

Ball Valve Dimensions*	
Size	V
1 1/2" NPT	4.4
1 1/2" 150# flange	6.5
1 1/2" 300# flange	7.5

\*Dimension of ball valve if supplied by Magnetrol.

- V Ball valve dimension (see chart)
- X Dimension from wall to top of ball valve
- Y Insertion length into pipe

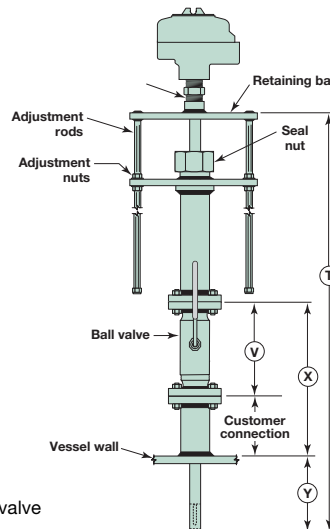

**High Pressure Hot Tap**  
minimum probe length  
 $T = 2(X + Y)$

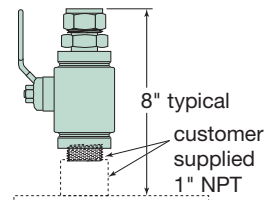

Part Number  
089-5218-001

# DIMENSIONAL SPECIFICATIONS

INCHES (mm)

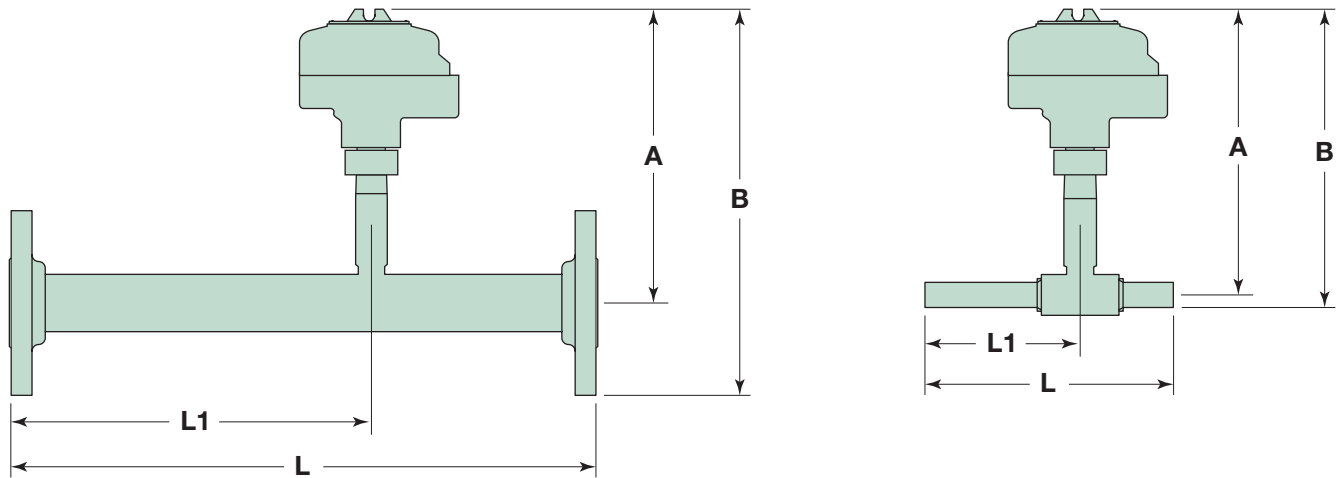

Code	Size	Length (L)		L1		Height to Centerline (A) inches (mm)	Overall Height (B)	
		With Flow Conditioning inches (mm)	Without Flow Conditioning inches (mm)	With Flow Conditioning inches (mm)	Without Flow Conditioning inches (mm)		NPT inches (mm)	Flange inches (mm)
0	½"	8 (203)	—	5 (127)	—	8.0 (203)	8.7 (221)	9.75 (248)
1	¾"	11.25 (381)	—	7.5 (190)	—	8.0 (203)	8.7 (221)	9.9 (251)
2	1"	15 (203)	—	10 (254)	—	8.0 (203)	8.7 (221)	10.1 (257)
3	1½"	19.5 (495)	7.5 (191)	12 (305)	3.75 (95)	8.35 (212)	9.3 (236)	10.85 (276)
4	2"	26 (660)	7.5 (191)	16 (406)	3.75 (95)	9.25 (235)	10.4 (264)	12.25 (311)
5	3"	39 (991)	10 (254)	24 (610)	5 (127)	9.25 (235)	N/A	13.0 (330)
6	4"	52 (1321)	12 (305)	36 (914)	6 (152)	9.25 (235)	N/A	13.75 (349)

## FLOW BODY SIZING

The following table is a general guide on flow sizing. Contact Magnetrol or your local representative for specific application information.

Code	Size	Air, N <sub>2</sub> , O <sub>2</sub>	Natural Gas, Methane	Digester Gas	Propane	Hydrogen	CO <sub>2</sub> , Argon
0	½"	65 SCFM 110 NM <sup>3</sup> /h	45 SCFM 76 NM <sup>3</sup> /h	25 SCFM 42 NM <sup>3</sup> /h	30 SCFM 51 NM <sup>3</sup> /h	15 SCFM 27 NM <sup>3</sup> /h	60 SCFM 105 NM <sup>3</sup> /h
1	¾"	120 SCFM 204 NM <sup>3</sup> /h	85 SCFM 140 NM <sup>3</sup> /h	45 SCFM 76 NM <sup>3</sup> /h	55 SCFM 93 NM <sup>3</sup> /h	30 SCFM 52 NM <sup>3</sup> /h	110 SCFM 190 NM <sup>3</sup> /h
2	1"	200 SCFM 340 NM <sup>3</sup> /h	140 SCFM 238 NM <sup>3</sup> /h	75 SCFM 127 NM <sup>3</sup> /h	95 SCFM 161 NM <sup>3</sup> /h	50 SCFM 85 NM <sup>3</sup> /h	190 SCFM 320 NM <sup>3</sup> /h
3	1½"	490 SCFM 833 NM <sup>3</sup> /h	340 SCFM 580 NM <sup>3</sup> /h	180 SCFM 310 NM <sup>3</sup> /h	230 SCFM 395 NM <sup>3</sup> /h	120 SCFM 208 NM <sup>3</sup> /h	465 SCFM 790 NM <sup>3</sup> /h
4	2"	715 SCFM 1220 NM <sup>3</sup> /h	505 SCFM 855 NM <sup>3</sup> /h	280 SCFM 480 NM <sup>3</sup> /h	350 SCFM 600 NM <sup>3</sup> /h	195 SCFM 332 NM <sup>3</sup> /h	680 SCFM 1155 NM <sup>3</sup> /h
5	3"	1765 SCFM 3000 NM <sup>3</sup> /h	1240 SCFM 2110 NM <sup>3</sup> /h	695 SCFM 1180 NM <sup>3</sup> /h	860 SCFM 1470 NM <sup>3</sup> /h	475 SCFM 812 NM <sup>3</sup> /h	1680 SCFM 2855 NM <sup>3</sup> /h
6	4"	3230 SCFM 5490 NM <sup>3</sup> /h	2260 SCFM 3845 NM <sup>3</sup> /h	1265 SCFM 2145 NM <sup>3</sup> /h	1575 SCFM 2675 NM <sup>3</sup> /h	865 SCFM 1478 NM <sup>3</sup> /h	3060 SCFM 5210 NM <sup>3</sup> /h

# MODEL NUMBER

## REMOTE TRANSMITTER USED WITH INSERTION PROBE

### INPUT VOLTAGE

0	120 VAC
1	240 VAC
2	24 VDC
3	120 VAC with heater
4	240 VAC with heater

### NUMBER OF RELAYS

0	None
2	Two
4	Four

### CALIBRATION

Actual Gas Calibration	
0	Special
1	Air
2	Nitrogen or Oxygen
3	Hydrogen
4	Natural Gas
5	Methane
6	Digester Gas
7	Propane
Air Equivalency Calibration	
9	Air Equivalency

### PROBE HOUSING

1	FM/CSA approved
D	ATEX approved

### CONDUIT CONNECTION

0	3/4" NPT
1	M20

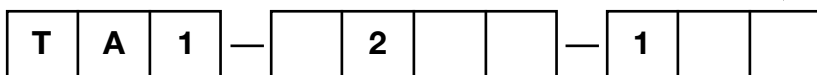

# MODEL NUMBER

## INSERTION PROBE

### UNIT OF MEASUREMENT

TER	Probe length in tenths of an inch
TMR	Probe length in centimeters

### MATERIALS OF CONSTRUCTION

A	316/316L stainless steel
B	Hastelloy C-276

### PROCESS CONNECTION

00	Compression fitting utilized <sup>① ②</sup>	43	2" 150# ANSI raised face flange
11	3/4" NPT threaded	44	2" 300# ANSI raised face flange
21	1" NPT	BA	DN25 PN 16, DIN 2527, Form B
22	1" BSP	BB	DN25 PN 25/4, DIN 2527, Form B
23	1" 150# ANSI raised face flange	CA	DN40 PN 16, DIN 2527, Form B
24	1" 300# ANSI raised face flange	CB	DN40 PN 25/4, DIN 2527, Form B
33	1 1/2" 150# ANSI raised face flange	DA	DN50 PN 16, DIN 2527, Form B
34	1 1/2" 300# ANSI raised face flange	DB	DN50 PN 25/40, DIN 2527, Form B

- ① Not available with Hastelloy C construction
- ② Customer supplied or purchased separately (see page 6 for part numbers)

### PROBE LENGTH

2.6 to 99.9 inches (example: 8.5" = 085) Minimum lengths: 2.6" (026) with threaded process connection 2.8" (028) with flanged process connection 4.5" (045) with compression fitting process connection
7 to 253 centimeters (example: 18 cm = 018) Minimum lengths: 7 cm (007) with threaded or flanged process connection 11 cm (011) with compression fitting process connection



# MODEL NUMBER

## CONNECTING CABLE

### CABLE LENGTH IN FEET

10 feet minimum, 250 feet maximum length  
Example: 50 feet = 050

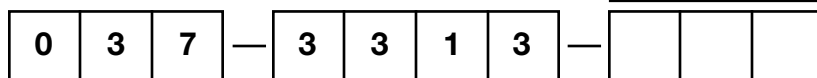

### CABLE LENGTH IN METERS

3 meters minimum, 75 meters maximum length  
Example: 8 meters = 008

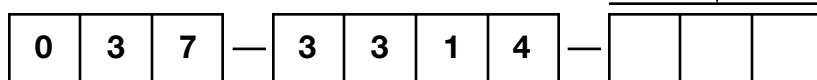

# MODEL NUMBER

## REMOTE TRANSMITTER USED WITH FLOW BODY

### INPUT VOLTAGE

0	120 VAC
1	240 VAC
2	24 VDC
3	120 VAC with heater
4	240 VAC with heater

### NUMBER OF RELAYS

0	None
2	Two
4	Four

### CALIBRATION

Actual Gas Calibration	
A	Special
B	Air
C	Nitrogen or Oxygen
D	Hydrogen
E	Natural Gas
F	Methane
G	Digester Gas
H	Propane
Air Equivalency Calibration	
K	Air Equivalency

### PROBE HOUSING

1	FM/CSA approved
D	ATEX approved

### CONDUIT CONNECTION

0	3/4" NPT
1	M20

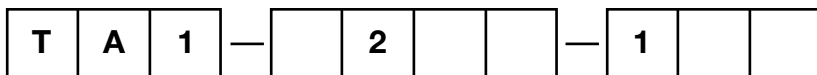

# MODEL NUMBER

## FLOW BODY

### MATERIALS OF CONSTRUCTION

A	All stainless steel
1	Carbon steel body with stainless steel sensor

### SIZE

0	½ inch
1	¾ inch
2	1 inch
3	1½ inch
4	2 inch
5	3 inch
6	4 inch

### PROCESS CONNECTION TYPE

1	NPT Threads (only when Digit 5 = 0, 1, 2, 3, or 4)
3	150# Flange

### FLOW CONDITIONER (stainless steel)

0	Not provided
1	Provided (only when Digit 5 = 3, 4, 5, or 6)

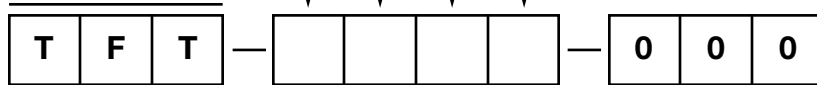

# MODEL NUMBER

## CONNECTING CABLE

### CABLE LENGTH IN FEET

10 feet minimum, 250 feet maximum length  
 Example: 50 feet = 050

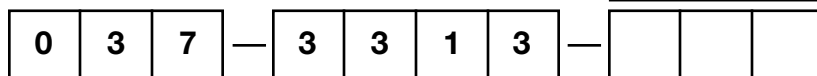

Longer cable lengths possible.  
 Consult Magnetrol with application details.

### CABLE LENGTH IN METERS

3 meters minimum, 75 meters maximum length  
 Example: 8 meters = 008

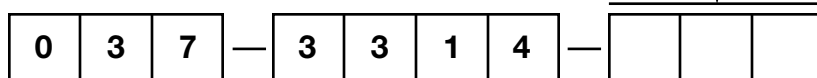

Longer cable lengths possible.  
 Consult Magnetrol with application details.

# QUALITY

---



The quality assurance system in place at Magnetrol guarantees the highest level of quality throughout the company. Magnetrol is committed to providing full customer satisfaction both in quality products and quality service.

Magnetrol's quality assurance system is registered to ISO 9001 affirming its commitment to known international quality standards providing the strongest assurance of product/service quality available.

# WARRANTY

---



All Magnetrol electronic level and flow controls are warranted free of defects in materials or workmanship for one full year from the date of original factory shipment. If returned within the warranty period; and, upon factory inspection of the control, the cause of the claim is determined to be covered under the warranty; then, Magnetrol will repair or replace the control at no cost

to the purchaser (or owner) other than transportation.

Magnetrol shall not be liable for misapplication, labor claims, direct or consequential damage or expense arising from the installation or use of equipment. There are no other warranties expressed or implied, except special written warranties covering some Magnetrol products.

## Additional information

The following additional Thermatel literature is available from your local representative:

- 54-620 Thermatel Model TA1 Mass Flow Transmitter Instruction Manual and Parts List
- 54-100 Thermatel Technology brochure
- 54-105 TG1/TG2 Thermal Dispersion Switch sales literature
- 54-110 Thermatel Model TD1/TD2 Thermal Dispersion Flow and Level Switch sales literature
- 54-130 TA2 Mass Flow Transmitter sales literature
- 54-131 TA1/TA2 Probe Location Brochure
- 54-210 Thermal Dispersion Mass Flow Meter Applications
- 54-621 Thermal Dispersion Mass Flow Measurement Handbook



5300 Belmont Road • Downers Grove, Illinois 60515-4499 • 630-969-4000 • Fax 630-969-9489 • [www.magnetrol.com](http://www.magnetrol.com)  
145 Jardin Drive, Units 1 & 2 • Concord, Ontario Canada L4K 1X7 • 905-738-9600 • Fax 905-738-1306  
Heikensstraat 6 • B 9240 Zele, Belgium • 052 45.11.11 • Fax 052 45.09.93  
Regent Business Ctr., Jubilee Rd. • Burgess Hill, Sussex RH15 9TL U.K. • 01444-871313 • Fax 01444-871317

Copyright © 2006 Magnetrol International, Incorporated. All rights reserved. Printed in the USA.  
Magnetrol and Magnetrol logotype are registered trademarks of Magnetrol International.

Performance specifications are effective with date of issue and are subject to change without notice.

**BULLETIN: 54-120.7**  
**EFFECTIVE: March 2006**  
**SUPERSEDES: December 2003**