



ORION
INSTRUMENTS
A Magnetrol® Company

THE NEXT GENERATION OF MAGNETIC LEVEL INDICATION

MAGNETIC LEVEL INDICATORS

DESCRIPTION

Magnetically coupled liquid level indicators, or MLIs, are in widespread use throughout process industries. Originally designed as an alternative to sight and gauge glass devices, the MLI is now commonly used in both new construction and plant expansion as well as replacement for high maintenance sight and gauge glasses.

Orion's Atlas, Gemini, and Aurora magnetic level indicators are precision engineered and manufactured to indicate liquid level accurately, reliably, and continuously. These units are completely sealed and require no periodic maintenance. MLIs also eliminate vapor or liquid emission problems common with sight and gauge glasses.

To complement these products, Orion produces a complete range of level switches and transmitters, including the Eclipse® Guided Wave Radar transmitter from Magnetrol International.

FEATURES

- Numerous chamber styles (or configurations) for each design. Custom designs available.
- Complete range of level switches and level transmitters, including Eclipse Guided Wave Radar
- Fabricated, non-magnetic chamber assembly produced in a wide range of metal and plastic materials
- ANSI and EN 1092 process connections available
- Precision manufactured float with internal magnets and magnetic flux ring
- Flag or shuttle type indicator with stainless steel scale to measure height, volume, or percentage of level
- Standard float stop springs at top and bottom of chamber
- Exceptional code qualified welding



Aurora®

Atlas™

Gemini™

APPLICATIONS

- Feedwater heaters
- Industrial boilers
- Oil/water separators
- Flash drums
- Surge tanks
- Gas chillers
- Deaerators
- Blowdown flash tanks
- Hot wells
- Vacuum tower bottoms
- Alkylation units
- Boiler drums
- Propane vessels
- Storage tanks

ATLAS & STRATUS MLI

The Atlas is Orion’s standard high-performance magnetic level indicator. Atlas is a single chamber design with either a 2”, 2½”, or 3” chamber diameter, as required by the application. There are twelve basic configuration styles including top mount models. Special configurations are also available.

Atlas MLIs are produced in a wide range of materials, including exotic alloys and plastics. Orion also offers the most complete selection of process connection types and sizes in the industry.

Atlas can be equipped with a variety of level transmitters and switches as well as flag and shuttle indicators with or without stainless steel scales. This enables the Atlas to be a complete level and monitoring control.

Stratus (not shown) is a simple, rugged, reliable, and cost-effective Magnetic Level Indicator. Suitable for a variety of installations, Stratus has many basic features and is precision engineered and manufactured to ensure a long service life.

GEMINI

Orion’s twin chamber design is unique to the Magnetic level gauge industry. Countless unique configuration styles are available with Gemini. It can be produced in the same metal material selections as Atlas.

The second chamber facilitates the installation of any of a wide selection of transmitters to provide continuous level monitoring in addition to the indication provided by the primary chamber. Eclipse guided wave radar, direct insertion Jupiter magnetostrictive, or Kotron capacitance type level transmitters can be mounted in the secondary chamber to provide totally redundant indication with continuous level output. The primary chamber, which houses the float, can be fitted with clamp-on switches or transmitters for additional level control.

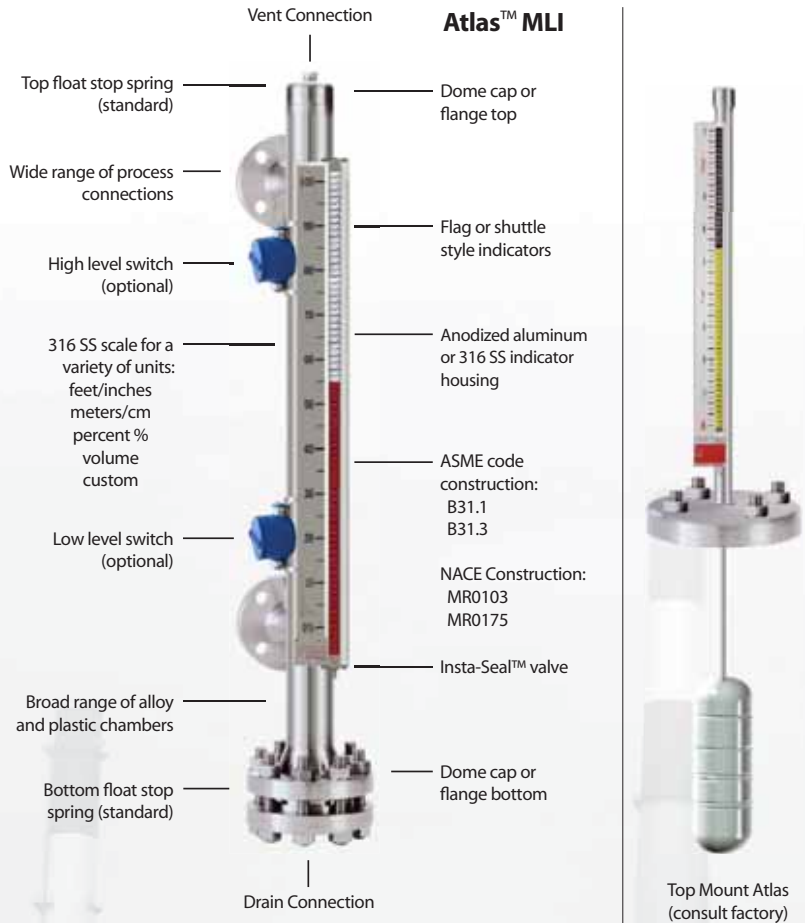

Aurora®



See Brochure ORI-101
for more information

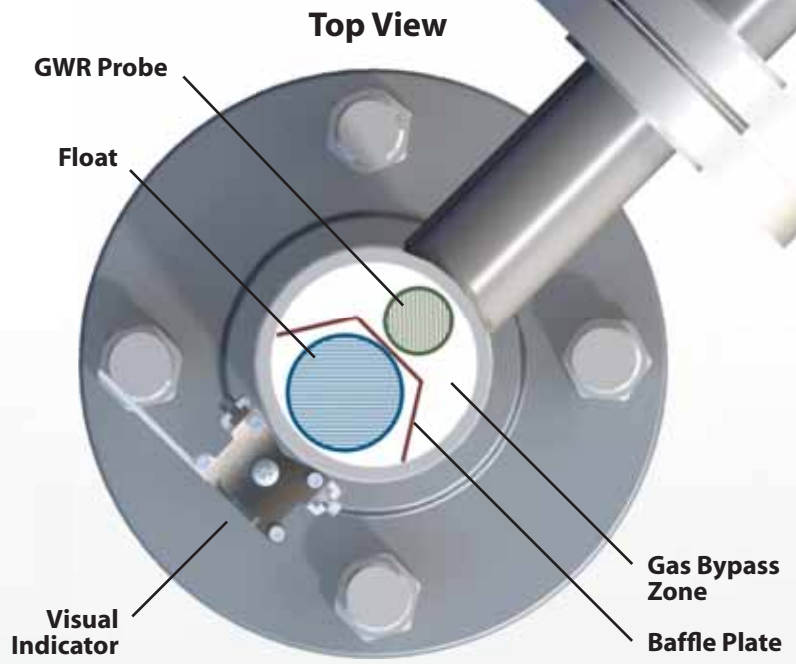

Eclipse® GWR
Level Transmitter



DESCRIPTION

Aurora's patented design is the next generation of magnetic level indicators. It is state of the art and reflects Orion's innovation and commitment to magnetic level indicators.

Aurora is a totally redundant monitoring and control system. Liquid levels are tracked with great accuracy using two different technologies. An Eclipse® guided wave radar probe is housed along with the MLI float in a 3" or 4" diameter chamber. While the indicator relies upon the float and its internal magnets to activate the flags or shuttle, the Eclipse measures the liquid level directly. Two completely separate technologies in a single external chamber equal redundancy unlike any other MLI. The use of a special baffle within the chamber ensures that the float and Eclipse® probe work seamlessly and without interference.

There are ten basic configuration styles and over fifteen material selections for Aurora. For the first time ever, the ability to accurately and reliably measure ultra low dielectric media, high pressure/high temperature process conditions, and media with shifting and changing dielectric values can be accomplished with Aurora.

AURORA® FEATURES

- Wide range of alloy materials
- Eclipse available with HART®, FOUNDATION fieldbus™, or PROFIBUS™ communication
- Large selection of process connection options
- Eight probe designs cover a broad range of applications
- Eclipse transmitter available in 316 stainless steel or epoxy-coated aluminum
- ASME B31.1, B31.3, or NACE; 150# to 2500# ANSI (PN 16 to PN 320)
- Top and bottom float stop springs

Orion high-visibility indicators are available in a variety of styles with several options to choose from. Our anodized aluminum flat-glass indicator employs a unique sealing mechanism via Glass-Lock technology and the Insta-Seal™ valve.

A tubular-glass stainless steel indicator is also available for the most extreme industrial environments around the world. Measuring scales are available in English, Metric, percent, and volumetric units (liters, gallons, etc).

Custom indicator designs are our specialty. Contact Orion Instruments or your local representative to learn more.



Insta-Seal™ Valve

OPTION: Float Diagnostics

Float Diagnostics adds an extra degree of safety to Orion Magnetic Level Indicators. By including an additional, different color set of flags below the zero mark, Float Diagnostics will alert a passer-by that the float has either lost buoyancy or collapsed due to over-pressurization. The float would sink into the bottom of the MLI and activate the full set of diagnostic flags. The diagnostic flags are a highly contrasting color to the rest of the indicator, thereby making it easily visible.

Styles of Visual Indication



Orange / Black



Yellow / Black



Red / White



Shuttle / Follower

OPTION: Vibration-Resistant Indicator

High amounts of vibration are not uncommon in many of the process and power applications around the world. Many times, the vibration can be severe enough to render certain instrumentation useless. Flag and Shuttle indicators can be affected by vibration in the short-term, as well as over time. Shuttle indicators should never be used for applications experiencing high vibration.

Orion's stainless steel indicator is available with a vibration-dampening inert liquid that surrounds and protects each flag inside the indicator.



Orion indicators incorporate a *positive-stop channel* design which limits the rotation of each flag to **180 degrees**. This eliminates "overflipping" which is commonly seen on other indicator designs.

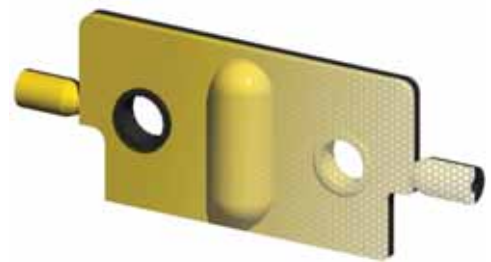

Orion's highly robust **metallic** flags offer **high visibility** and protection against the sun via a **UV resistant powder coating**.

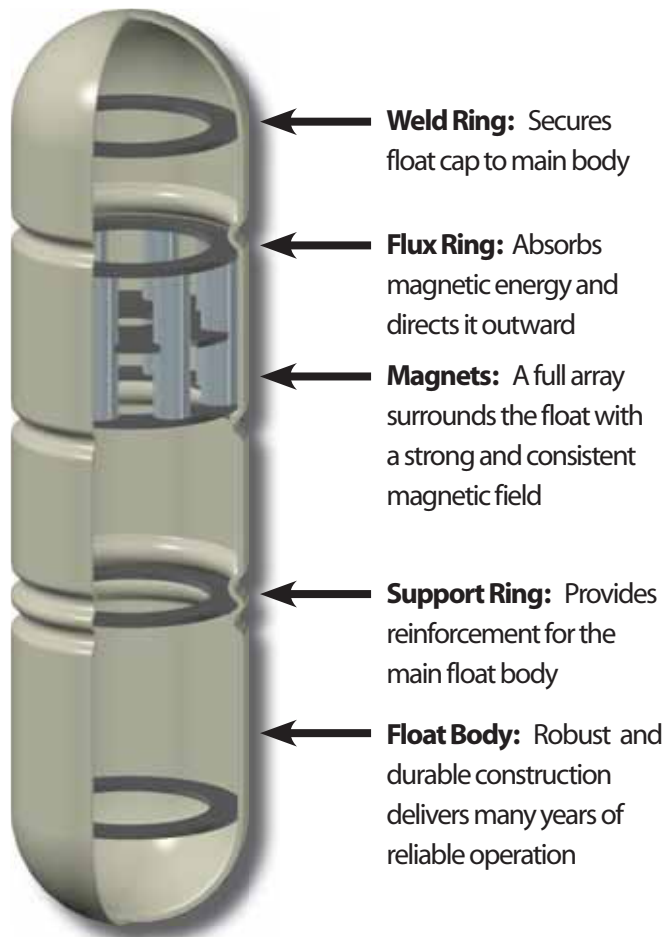

ORION FLOAT TECHNOLOGY

The float contained within the magnetic level indicator is perhaps the most important element of the instrument. Its structural design, volume displacement, weight, and buoyancy force are all carefully considered when a float is specified for a particular application.

Orion engineers have designed and tested hundreds of floats to gather the most accurate data available. We have designs for thousands of unique applications around the world, including high pressure, high temperature, and interface.

Orion's 360° magnet assembly produces a strong and consistent flux array allowing visual indication through chambers as thick as schedule 160.

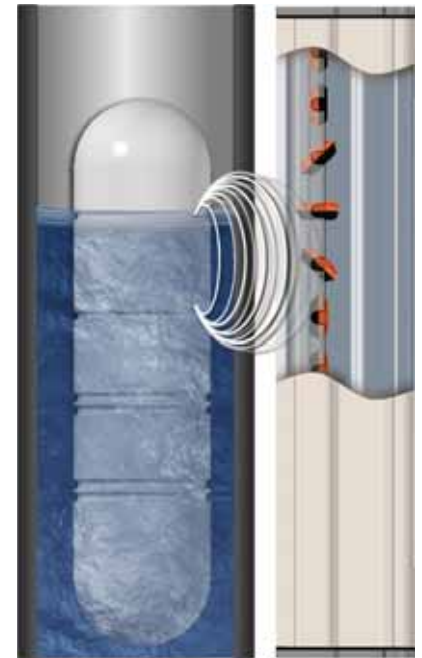
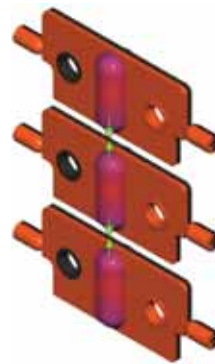

High-strength magnets inside each flag facilitate an extremely strong attraction with the float. This also ensures a proper vertical alignment so that the indicator does not display unwanted flipping.

CAPABILITIES

- Process pressures up to 4,500+ psig (310 bar) ①
- Process Temperatures up to 1,000° F (538° C) ①
- Total level specific gravities as low as 0.25 ①
- Interface float designs available for liquid specific gravity differentials as little as 0.1
- Adequate buoyancy to operate effectively and freely in many viscous liquids, including crude oil

① maximum capabilities can vary depending on combination of pressure, temperature, and media specific gravity

OPTIONS

- Teflon®-S PTFE slip-assistant coating
- Halar® ECTFE Coating for abrasion and chemical resistance
- Float retrieval hook
- Float Projection Curve: If the liquid density changes, a float curve will reveal the offset

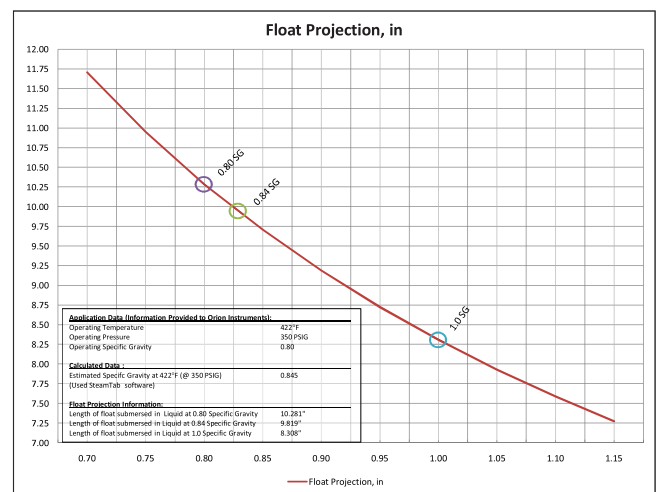

Float Projection Curve

Design	Atlas, Aurora, Stratus – single chamber Gemini – dual chamber
Materials of construction – MLI	Metal alloys 316/316L or 304/304L stainless steel, 321 stainless steel, 347 stainless steel, Titanium, Monel, Hastelloy B, Hastelloy C-276, Inconel 625, Inconel 825, Alloy 20, Electropolished 316 stainless steel, 904L stainless steel and other non-magnetic alloys
	Plastics / Composites Fiberglass, PVC, CPVC, Kynar, polypropylene
Materials of construction – Float	varies per application - stainless steel and titanium are standard (exotic alloys available)
Construction options	Conformance to ASME B31.1, ASME B31.3, and NACE available
Certified material test reports (CMTR)	Available upon request
Pressure class ratings	ANSI 150#, 300#, 600#, 900#, 1500#, 2500# DIN PN16, PN25, PN40, PN63, PN100, PN160, PN250, PN320
Process connection sizes	1/2" to 8" DN 20 to DN 150
Process connection types	MNPT, FNPT, Weldolet [®] , Sockolet [®] , threaded nipple, buttweld nipple, plain-end nipple, slip-on flanges, weldneck flanges, lap joint flanges, TriClamp [®] fitting, Van Stone flanges
Measuring range	12 to 600 in (30 to 1524 cm)
Temperature range	-320° to +1000° F (-196° to +538° C)
Pressure range	Full vacuum to 4500 psig (310 bar)
Specific gravity range	As low as 0.25 S.G. (consult factory for lower specific gravities)
Indicators	Magnetically actuated flag assembly in contrasting orange/black, yellow/black, red/white colors, or high visibility shuttle follower (custom colors available)
Flag assembly seal	Inert gas filled and sealed with Insta-Seal™ valve
Visual indication	Easily visible from 100 feet (30 meters)
Scale options	Etched stainless steel with either height, volume, or percentage units (custom markings avail)
Switch options	Model OES electric cam operated snap action (refer to Orion bulletin: OES-100) Model ORS electric reed type (refer to Orion bulletin: ORS-300) Pneumatic switch available (consult factory)
Transmitter options	Model 705 Eclipse guided wave radar (refer to Magnetrol bulletin: 57-101 & 57-102) Model 2xx Jupiter Magnetostrictive (refer to Orion bulletin: ORI-148) Model OCT analog reed chain (refer to Orion bulletin: OCT-400)
High temperature options	Electric or steam tracing with or without special high temperature insulation
Low temperature options	Cryogenic insulation with special polymeric frost extension

HIGH-TEMPERATURE INSULATION

Orion specializes in custom fiberglass insulation blankets for MLIs of all shapes and sizes. They are constructed with high-quality materials capable of constant contact with temperatures up to 1,000° F (538° C). This insulation is available as personnel protection or with heat tracing options for freeze protection or process temperature maintenance.



CRYOGENIC INSULATION & FROST EXTENSION

To facilitate operation where the product is kept cold via chillers, refrigerants, and condensers, cryogenic insulation is provided. By insulating the MLI with a specialized cryogenic jacket, process temperatures can be maintained in the liquid state down to -320° F (-195° C).

A frost extension option is available to prevent ice from collecting on the visual indicator, thereby decreasing the visibility. The extension is constructed of durable acrylic plastic and is provided standard with all cryogenic insulation.

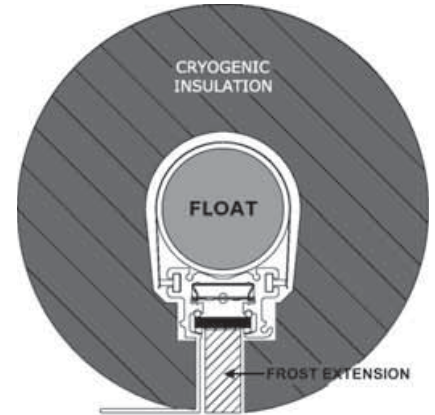

MAGNETIC PARTICLE TRAP

Magnetic Particle Traps, or Magtraps, provide protection for Orion’s line of Magnetic Level Indicators. Particles composed mostly of ferrite, often from carbon steel piping, are widespread throughout process piping. These particles enter the MLI via the process connections during normal fill and drain operations. The magnetic float located inside the MLI attracts these particles over time. Eventually, the build-up will be enough to cause the float to become stuck inside the chamber. This results in the MLI either reading inaccurately or not at all. The trap collects the particles which can be cleaned periodically to ensure continued operation of the magnetic level indicator.

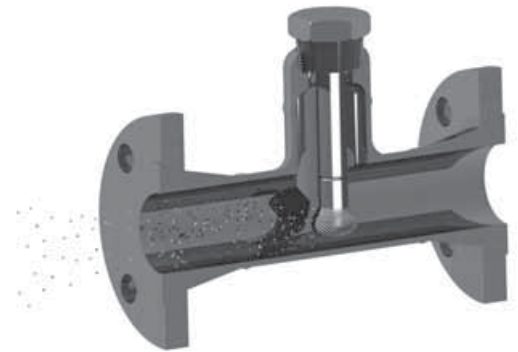

HEAT TRACING: ELECTRIC & STEAM

For applications where process freeze protection or temperature maintenance is required, heat tracing will allow the MLI to operate uninterrupted throughout harsh, cold conditions.

Electric Heat Tracing is available in self-regulating, constant wattage, and mineral insulated varieties. Contact the factory for more information.

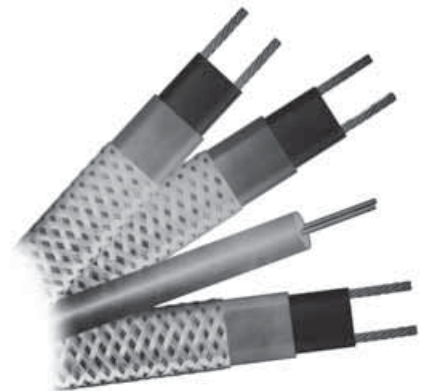

TRANSMITTER SPECIFICATIONS

	Eclipse Guided Wave Radar	Jupiter Magnetostrictive
Measuring Range:	6 to 240 inches (15 to 610 cm)	6 to 400 inches (15 to 999 cm)
Resolution:	0.01 mA analog 0.1 inch (cm) display	0.01 mA analog 0.1 inch (cm) display
Repeatability:	<0.1 inch (2.5 mm)	±0.005% of full span or 0.005 inches (0.127 mm) (whichever is greater)
Non-Linearity:	<0.1% of probe length or 0.1 inch (2.5 mm) (whichever is greater)	0.020% of full span or 0.031 inches (0.794 mm) (whichever is greater)
Upper Dead Zone:	None	less than 3 inches (7.6 cm) when bottom mounted electronics
Lower Dead Zone:	None	less than 3 inches (7.6 cm) when top mounted electronics
Damping:	0 - 10 seconds; adjustable	0 - 25 seconds; adjustable
Power (at terminals):	GP/IS: 11 to 28.6 VDC EP (with IS probe): 13.5 to 28 VDC FOUNDATION fieldbus™ & PROFIBUS PA™(FISCO): 9 to 17.5 VDC FOUNDATION fieldbus™ & PROFIBUS PA™(FNICO Exd): 9 to 32 VDC	HART®: 12 to 28 VDC FOUNDATION fieldbus™ Explosion Proof: 9 to 17.5 VDC FISCO/FNICO: 9 to 17.5 VDC
Signal Output:	4-20 mA with HART®: 3.8 to 20.5 mA usable FOUNDATION fieldbus™: H1 (ITK Ver. 5.01) PROFIBUS PA™: PROFIBUS PA™ H1	4-20 mA with HART®: 3.8 to 20.5 mA usable FOUNDATION fieldbus™: H1 (ITK Ver. 4.61)
Display:	2 line x 8 character LCD	2 line x 8 character LCD
Housing Material:	IP66/Aluminum A356T6 or 316 SS	NEMA 4X/7/9IP66/Aluminum A356T6 or 316 SS
Area Classifications:	FM/CSA/ATEX/IEC - EP, IS, NI (see specific product literature for more detail)	FM/CSA/ATEX/IEC/INMETRO - EP, IS, NI (see specific product literature for more detail)
Safety Integrity Level:	Standard Electronics: SIL 1 as 1oo1, SFF 85.4% Enhanced Electronics: SIL 2 as 1oo1, SFF 91%	Standard Electronics: SIL 1 as 1oo1, SFF 83.7% Enhanced Electronics: SIL 2 as 1oo1, SFF 90.7%
Process Temperature:	probe dependent (see specific product literature for more detail)	External Mount: -320° F to +850° F Direct Insertion: -320° F to + 500° F
Ambient Temperature at Electronics:	-40° to 175° F (-40° to 80° C) LCD: -5° to +160° F (-20° to +70° C)	-40° to 175° F (-40° to 80° C) LCD: -10° to +160° F (-20° to +70° C)
Process Pressure:	probe dependent (see specific product literature for more detail)	Direct insertion: +1700 psig (117 bar) (see specific product literature for more detail)
Mounting Arrangement:	Direct insertion probe with integral mount or remote mount electronics	Direct insertion probe with integral mount or external top or bottom mount on MLI

TRANSMITTER SPECIFICATIONS

	OCT Reed Chain
Measuring Range:	6 to 198 inches (15 to 503 cm)
Resolution:	±0.50 inches (13 mm)
Repeatability:	< 0.25 inches (6 mm)
Non-Linearity:	<0.4% full span averaged over span
Upper Transition Zone:	4 inches (10.2 cm)
Lower Transition Zone:	4 inches (10.2 cm)
Power Input:	12 to 36 VDC
Signal Output:	4 to 20 mA
Housing Type:	NEMA 4X, IP66
Housing Material:	Cast Aluminum or 316 SS
Area Classifications:	FM/CSA EP
Process Temperature:	-40° to +425° F (-40° to +218° C)
Ambient Temperature at Electronics:	-40° to +158° F (-40° to +70° C)
Mounting Arrangement:	External mount probe with integral top or bottom mounted electronics

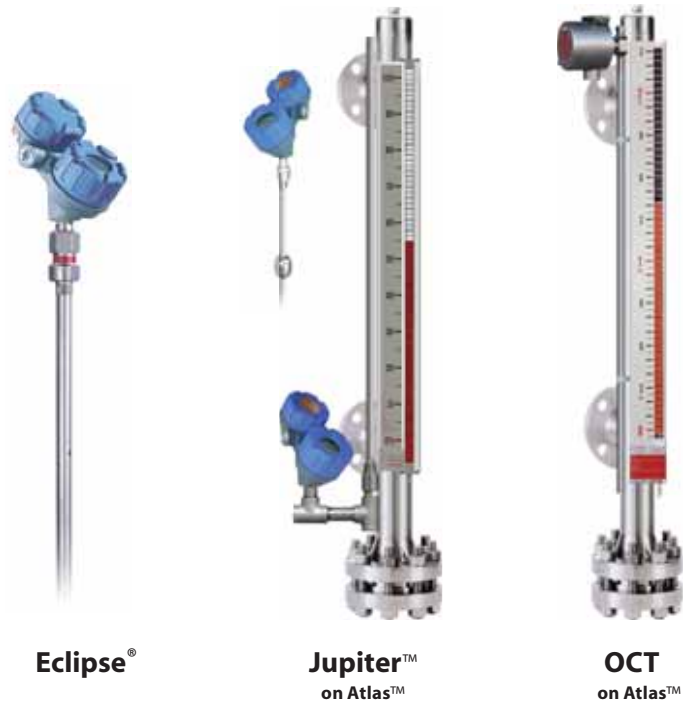

ELECTRONIC SWITCH SPECIFICATIONS

Model:	OES	ORS
Description:	SPDT magnetically actuated, bi-stable cam drive snap action switch	Hermetically sealed bi-stable reed switch
Supply Voltage:	250V AC/DC max	150V AC/DC max
Maximum Dead Band:	±0.75" float travel	±0.50" float travel
Temperature Range:	-58° to +392° F (-50° to +200° C)	-58° to +482° F (-50° to +250° C)
Enclosure Rating:	NEMA 4X	NEMA 4X
Enclosure Material:	Cast aluminum (standard)	Stainless steel



Model OES











Model ORS

PNEUMATIC SWITCH SPECIFICATIONS

consult factory for more information regarding pneumatic switches

AGENCY APPROVALS | POINT LEVEL SWITCHES & REED CHAIN TRANSMITTER

Agency	Model	Area Classification
FM 	OES-xxxx-001	Class I, II, III, Div. 1, Groups B,C,D,E,F,G; T6 @ 80°C; Type 4X
	ORS-xxxx-001	Class I, II, III, Div. 1, Groups B,C,D,E,F,G; T6 @ 80°C; Type 4X Class I, Div. 2, Groups A, B, C, & D; T6 @ 80°C
	OCT-xxxx-xxx	Class I, II, III, Div. 1, Groups B,C,D,E,F,G; T6 @ 80°C; Type 4X Class I, Div. 2, Groups A, B, C, & D; T6 @ 80°C
CSA 	OES-x1xx-001	Class I, Div. I/II, Groups B, C, & D; T6 @ 80°C; Type 4X Class II, Groups E, F, & G; T6 @ 80°C; Type 4X Class III
	ORS-x1xx-001	Class I, Div. I, Groups B, C, & D; T6 @ 80°C; Type 4X
	OCT-xxxx-001	Class I, Div. II, Groups A, B, C, & D; T6 @ 80°C; Type 4X Class II, Groups E, F, & G; T6 @ 80°C; Type 4X Class III
ATEX 	ORS-xAxx-001	ATEX II 2 G Ex d IIC T6 Ta = -40 to +70° C
IEC 	ORS-xAxx-001	IECEx d IIC T6 Ta = -40 to +70° C
CE 	OES-xxxx-001	Low Voltage Directives, 2006/95/EC
	ORS-xxxx-001	Installation Category II, Pollution Degree 2
	OCT-xxxx-xxxx	

Agency	Model	Protection Method	Area Classification
FM 	705-5XXX-1XX 705-5XXX-2XX	Intrinsically Safe	Class I, Div. 1, Groups A, B, C, & D Class II, Div. 1, Groups E, F, & G T4 Class III, Type 4X, IP66 Entity
	705-5XXX-3XX 705-5XXX-4XX	Explosion Proof ① (with Intrinsically Safe probe)	Class I, Div. 1, Groups B, C, & D Class II, Div. 1, Groups E, F, & G T4 Class III, Type 4X, IP66
	705-5XXX-XXX 705-5XXX-XXX	Non-Incendive Suitable for: ②	Class I, Div. 2, Groups A, B, C, & D Class II, Div. 2, Groups F & G T4 Class III, Type 4X, IP66
CSA 	705-5XXX-1XX 705-5XXX-2XX	Intrinsically Safe	Class I, Div. 1, Groups A, B, C, & D Class II, Div. 1, Groups E, F, & G T4 Class III, Type 4X Entity
	705-5XXX-3XX 705-5XXX-4XX	Explosion Proof ① (with Intrinsically Safe probe)	Class I, Div. 1, Groups B, C, & D Class II, Div. 1, Groups E, F, & G T4 Class III, Type 4X
	705-5XXX-XXX 705-5XXX-XXX	Non-Incendive Suitable for: ②	Class I, Div. 2, Groups A, B, C, & D Class II, Div. 2, Groups E, F, & G T4 Class III, Type 4X
ATEX 	705-5XXX-AXX 705-5XXX-BXX	Intrinsically Safe ③	⊕ II 1G, EEx ia IIC T4 FISCO
	705-5XXX-CXX 705-5XXX-DXX	Flame Proof	⊕ II 1/2G, EEx d [ia] IIC T6
	705-51XX-EXX 705-51XX-FXX	Non-sparking	⊕ II 3(1)G, EEx nA [ia] IIC T4..T6 with probe II 1 G EEx ia IIC T6
	705-52XX-EXX 705-52XX-FXX		⊕ II 3(1)G, EEx nA [nL] [ia] IIC T4..T6 with probe II 1 G EEx ia IIC T6
IEC 	705-5XXX-AXX 705-5XXX-BXX	Intrinsically Safe ③	Zone 0 Ex ia IIC T4 FISCO



These units are in conformity of:

1. The EMC Directive: 2004/108/EC. The units have been tested to EN 61326.
2. Directive 94/9/EC for equipment or protective system for use in potentially explosive atmospheres.





Note: Single and twin rod probes must be used in metallic vessel or stillwell to maintain CE compliance.

① Factory Sealed: This product has been approved by Factory Mutual Research (FM), and Canadian Standards Association (CSA), as a Factory Sealed device.

② **IMPORTANT:** Measured media inside vessel must be non-flammable only. If media inside vessel is flammable, then the explosion proof version (which contains an internal barrier making the probe Intrinsically Safe) is required.

③ Special conditions for safe use
Because the enclosure of the Guided Wave Radar Level Transmitter Eclipse Model 705-5____-1_ and/or Probe Eclipse Model 7____-____ is made of aluminum, if it is mounted in an area where the use of category 1 G (Zone 0) apparatus is required, it must be installed such, that, even in the event of rare incidents, ignition sources due to impact and friction sparks are excluded.

For applications in explosive atmospheres caused by gases, vapours or mists and where category 1G (Zone 0) apparatus is required, electrostatic charges on the non-metallic parts of the Probe Eclipse Model 7x5-____-____, Model 7x7-____-____, and Model 7_F-____-____ shall be avoided.

Agency	Model	Protection Method	Area Classification
FM & CSA  	2xx-1xxx-xxxxx-xxx	Intrinsically Safe	Class I, Div. 1, Groups A, B, C, & D, T4 Ta @ 80°C Class II, Div. 1, Groups E, F, & G; Class III, T4 Ta @ 80°C IP66 TYPE 4X Entity
	2xx-3xxx-xxxxx-xxx	Explosion Proof ①③	Class I, Div. 1, Groups B, C, & D, T5 Ta @ 80°C Class II, Div. 1, Groups E, F, & G; Class III, T5 Ta @ 80°C IP66 Type 4X
	2xx-1xxx-xxxxx-xxx 2xx-2xxx-xxxxx-xxx	Non-Incendive ④	Class I, Div. 2, Groups A, B, C, & D, T5 Ta @ 80°C Class II, Div. 2, Groups E, F, & G②; Class III, T5 Ta @ 80°C IP66 Type 4X T5
ATEX 	2xx-Axxx-xxxxx-xxx	Flame Proof	Ex II 1/2 G EEx d IIC T6 @ 70°C
	2xx-Bxxx-xxxxx-xxx	Intrinsically Safe	Ex II 1 G EEx ia IIC T4 @ 70°C FISCO
IEC 	2xx-Cxxx-xxxxx-xxx	Flame Proof	Ex d IIC T6 @ 70°C
	2xx-Dxxx-xxxxx-xxx	Intrinsically Safe ⑤	Ex ia IIC T4 @ 70°C Ga FISCO
INMETRO 	2xx-Fxxx-xxxxx-xxx	Flame Proof	Br- Ex d IIC T6 @ 70°C, IP66W
	2xx-Gxxx-xxxxx-xxx	Intrinsically Safe ⑤	Br-Ex ia IIC T4 @ 70°C, IP66W FISCO



These units are in conformity of:
 1. The EMC Directive: 2004/108/EC. The units have been tested to EN 61326.
 2. Directive 94/9/EC for equipment or protective system for use in potentially explosive atmospheres.

- ① M20 conduit connections not CSA approved explosion proof
- ② FM approval class II, Div. 2 Groups F & G only
- ③ Factory Sealed: This product has been approved by Factory Mutual Research (FM), and Canadian Standards Association (CSA), as a Factory Sealed device.
- ④ **IMPORTANT:** Measured media inside vessel must be non-flammable only. If media inside vessel is flammable, then the explosion proof version (which contains an internal barrier making the probe Intrinsically Safe) is required.
- ⑤ **Special conditions for safe use**
 Materials marked as category 1 equipment and used in hazardous areas requiring this category, shall be installed in such a way that, even in the event of rare incidents, the aluminum enclosure cannot be an ignition source due to impact or friction.

ADDITIONAL CERTIFICATIONS

GOST R Russian Certificate of Conformity
GOST Pattern Approval Certificate for Measuring Instruments (Metrology Certificate)
GOST R Ex-Proof Certificate of Conformity

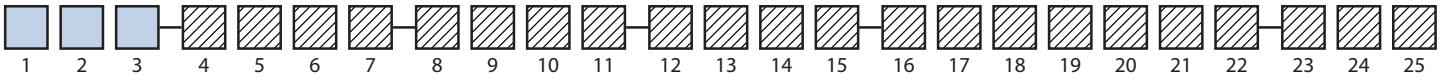

1 | PRODUCT TYPE

1	Atlas MLI
2	Aurora MLI with Eclipse® GWR transmitter
3	Gemini dual-chamber MLI with Eclipse® GWR
4	Stratus MLI
5	External Cage for Jupiter® transmitter

2 | UNIT OF MEASURE

E	English Units (Inches)	Specifies the unit of measure for the Center-to-Center and Visual Indication Length (digits 18 - 20)
M	Metric Units (Centimeters)	

Select the appropriate **Chamber Configuration** from the following five tables (match product type from digit 1)

3¹ | ATLAS - CHAMBER CONFIGURATION

Process Connection Orientation	Chamber Top	Chamber Bottom
1 Side / Side	Dome cap	Flanged (including mating blind flange)
2 Side / Side	Flanged (including mating blind flange)	Dome cap
3 Side / Side	Flanged (including mating blind flange)	Flanged (including mating blind flange)
4 Top / Bottom	Flanged	Flanged
5 Top / Bottom with Spool Pieces	Flanged (including mating blind flange)	Flanged (including mating blind flange)
6 Top / Side	Flanged	Flanged (including mating blind flange)
7 Top / Side	Dome cap with process connection	Flanged (including mating blind flange)
8 Side / Bottom	Flanged (including mating blind flange)	Flanged
9 Side / Bottom	Flanged (including mating blind flange)	Dome cap with process connection
T Top Mount	Threaded cap	Flanged process connection ①

① See pg. 19 for additional mounting options, or consult factory for custom solutions.

3² | AURORA - CHAMBER CONFIGURATION

Process Connection Orientation	Chamber Top	Chamber Bottom
1 Side / Side	Welded cap with threaded Eclipse probe	Flanged (including mating blind flange)
2 Side / Side	Flanged with threaded Eclipse probe	Dome cap
3 Side / Side	Flanged with threaded Eclipse probe	Flanged (including mating blind flange)
4 Side / Side	Flanged with seal welded Eclipse probe	Dome cap
5 Side / Side	Flanged with seal welded Eclipse probe	Flanged (including mating blind flange)
A Side / Bottom	Welded cap with threaded Eclipse probe	Flanged with process connection
B Side / Bottom	Flanged with threaded Eclipse probe	Dome cap with process connection
C Side / Bottom	Flanged with threaded Eclipse probe	Flanged with process connection
D Side / Bottom	Flanged with seal welded Eclipse probe	Dome cap with process connection
F Side / Bottom	Flanged with seal welded Eclipse probe	Flanged with process connection

3³ | GEMINI - CHAMBER CONFIGURATION

Process Connection Orientation	Primary Chamber Top	Primary Chamber Bottom	Secondary Chamber (with Eclipse GWR transmitter) ①	
			Top	Bottom
1 Side / Side	Dome cap	Flanged (with blind)	Dome cap with threaded Eclipse	Dome cap
2 Side / Side	Flanged (with blind)	Dome cap	Dome cap with threaded Eclipse	Dome cap
3 Side / Side	Flanged (with blind)	Flanged (with blind)	Dome cap with threaded Eclipse	Dome cap
4 Side / Side	Dome cap	Flanged (with blind)	Flanged with threaded Eclipse	Dome cap
5 Side / Side	Flanged (with blind)	Dome cap	Flanged with threaded Eclipse	Dome cap
6 Side / Side	Flanged (with blind)	Flanged (with blind)	Flanged with threaded Eclipse	Dome cap
7 Side / Side	Dome cap	Flanged (with blind)	Flanged with threaded Eclipse	Flanged (with blind)
8 Side / Side	Flanged (with blind)	Dome cap	Flanged with threaded Eclipse	Flanged (with blind)
9 Side / Side	Flanged (with blind)	Flanged (with blind)	Flanged with threaded Eclipse	Flanged (with blind)
A Top / Bottom	Flanged	Flanged	Dome cap with threaded Eclipse	Dome cap
B Top / Bottom	Flanged	Flanged	Flanged with threaded Eclipse	Dome cap
C Top / Bottom	Flanged	Flanged	Flanged with threaded Eclipse	Flanged (with blind)

① consult factory for seal welded Eclipse probe in secondary chamber

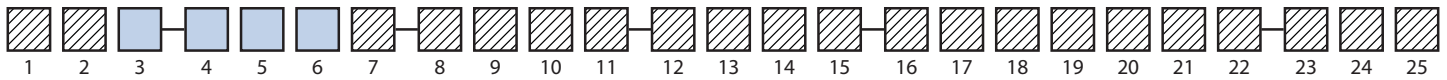

3⁴ | STRATUS - CHAMBER CONFIGURATION

Process Connection Orientation		Chamber Top	Chamber Bottom
1	Side / Side	Dome cap	Flanged (including mating blind flange)
2	Side / Side	Flanged (including mating blind flange)	Dome cap
3	Side / Side	Flanged (including mating blind flange)	Flanged (including mating blind flange)
4	Top / Bottom	Flanged	Flanged
5	Top / Bottom with Spool Pieces	Flanged (including mating blind flange)	Flanged (including mating blind flange)
6	Top / Side	Flanged	Flanged (including mating blind flange)
7	Top / Side	Dome cap with process connection	Flanged (including mating blind flange)
8	Side / Bottom	Flanged (including mating blind flange)	Flanged
9	Side / Bottom	Flanged (including mating blind flange)	Dome cap with process connection

3⁵ | EXTERNAL CAGE FOR JUPITER DIRECT INSERTION - CHAMBER CONFIGURATION

Process Connection Orientation		Chamber Top	Chamber Bottom
2	Side / Side	Flanged (with threaded Jupiter probe)	Dome Cap
3	Side / Side	Flanged (with threaded Jupiter probe)	Flanged (including mating blind flange)
8	Side / Bottom	Flanged (with threaded Jupiter probe)	Flanged
9	Side / Bottom	Flanged (with threaded Jupiter probe)	Dome Cap with Spool Piece
B	Side / Side	Flanged (with seal welded Jupiter probe)	Dome Cap
C	Side / Side	Flanged (with seal welded Jupiter probe)	Flanged (including mating blind flange)
H	Side / Bottom	Flanged (with seal welded Jupiter probe)	Flanged
J	Side / Bottom	Flanged (with seal welded Jupiter probe)	Dome Cap with process connection

4 | FLANGE RATING

ANSI		EN 1092	
A	150#	1	PN 16
B	300#	2	PN 25
C	600#	3	PN 40
D	900#	4	PN 63
E	1500#	5	PN 100
F	2500#	6	PN 160
		7	PN 250
		8	PN 320

5 | MATERIAL SELECTION

Stainless Steels	
A	316/316L Stainless Steel
B	316/316L Stainless Steel w/Carbon Steel Flanges
C	304/304L Stainless Steel
D	304/304L Stainless Steel w/Carbon Steel Flanges
F	317 Stainless Steel
G	321 Stainless Steel
H	347 Stainless Steel
J	904L Stainless Steel
K	Electropolished 316 Stainless Steel

Exotic Alloys	
N	Titanium
P	Monel® 400
Q	Hastelloy C-276
R	Alloy 20
S	Inconel® 625
T	Incoloy® 825

Carbon Steels (for External Cage product only)	
L	Carbon Steel

Plastics / Composites	
1	PVC
2	CPVC
3	Kynar
4	Polypropylene
5	Fiberglass

6 | CONSTRUCTION CODE OPTIONS

1	Industrial Grade (std.)
2	ASME B31.1 for Power Piping Standard
3	ASME B31.3 for Process Piping Standard
6	ASME B31.3 for Process Piping Standard and NACE MR0103
7	ASME B31.3 for Process Piping Standard and NACE MR0175
8	PED

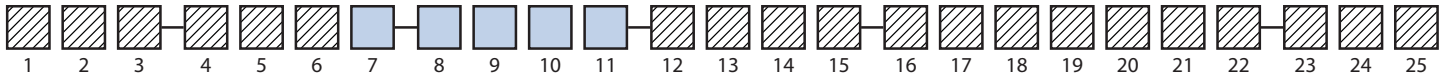

7 | CHAMBER FLANGE STYLE

A	RF Slip-on Flange	G	FF Socketweld Flange
B	RF Weldneck Flange	H	RTJ Slip-on Flange
C	RF Socketweld Flange	J	RTJ Weldneck Flange
D	FF Slip-on Flange	K	RTJ Socketweld Flange
F	FF Weldneck Flange	L	RF Lap Joint Flange

P	Full Face Socket Flange (for plastic units only)
Q	Socket Flange, Serrated Face (for fiberglass units only)

EN 1092 European Standard	
6	EN 1092 Type 11 with Type A Face
7	EN 1092 Type 11 with Type B2 Face
8	EN 1092 Type 12 with Type A Face
9	EN 1092 Type 12 with Type B2 Face

9 | PROCESS CONNECTION SIZE

Standard		EN 1092	
A	1/2"	1	DN 15
B	3/4"	2	DN 20
C	1"	3	DN 25
D	1 1/2"	4	DN 40
E	2"	5	DN 50
F	2 1/2"	6	DN 65
G	3"	7	DN 80
H	4"	8	DN 100
J	6"	9	DN 150
K	8"		

11 | CHAMBER FLANGE BOLTING

Stainless Steel		
A	304 stainless steel (standard)	A193 Gr.B8 Class I / A194 Gr.8
B	304 stainless steel w/PTFE coating	A193 Gr.B8 Class I / A194 Gr.8
C	316 stainless steel	A193 Gr.B8M Class I / A194 Gr.8M
D	316 stainless steel w/PTFE coating	A193 Gr.B8M Class I / A194 Gr.8M

Alloy Steel		
M	Alloy Steel	A193 Gr.B7 Class I / A194 Gr.2H
Q	Alloy Steel w/cadmium plating	A193 Gr.B7 Class I / A194 Gr.2H

N	None (if no mating flanges are supplied)
---	--

8 | PROCESS CONNECTION TYPE

Flanged (Alloy)		Other	
A	RF Slip-on Flange	M	Male Threaded (NPT)
B	RF Weldneck Flange	N	Female Threaded (NPT)
C	RF Socketweld Flange	P	Plain-end Nipple
D	FF Slip-on Flange	Q	Socketweld
F	FF Weldneck Flange	R	Buttweld
G	FF Socketweld Flange	S	Weldolet™
H	RTJ Slip-on Flange	T	Sockolet™
J	RTJ Weldneck Flange	W	Threadolet™
K	RTJ Socketweld Flange	Y	Tri-Clamp® Fitting
L	RF Lap Joint Flange		

Flanged (Plastic / Composite)	
1	Van-Stone Socket Flange (2-Piece, for PVC / CPVC units only)
2	Full Face Socket Flange (for plastic units only)
3	Serrated Face Socket Flange (for fiberglass units only)

EN 1092 European Standard	
6	EN 1092 Type 11 with Type A Face
7	EN 1092 Type 11 with Type B2 Face
8	EN 1092 Type 12 with Type A Face
9	EN 1092 Type 12 with Type B2 Face

10 | GASKET STYLE

Gaskets for Metallic Flanges		
A	Flexible graphite ring ①	
B	Spiral wound with graphite filler and carbon steel outer ring ② ③	
C	Spiral wound with graphite filler, inner ring matching chamber material ③, and carbon steel outer ring	
D	RTJ oval ring ④	
E	RTJ octagonal ring ④	
F	Virgin PTFE Ring	-140° to +450° F (-96° to +232° C)

Gaskets for Plastic/Composite Flanges		
P	EPDM rubber	-40° to +200° F (-40° to +93° C)
Q	Neoprene rubber	-60° to +250° F (-51° to +121° C)
R	Buna-N / Nitrile rubber	-60° to +250° F (-51° to +121° C)
S	ePTFE soft ring (expanded)	-140° to +450° F (-96° to +232° C)
T	Viton®	-15° to +300° F (-26° to +149° C)

N	None
---	------

① Standard gasket for 150# and 300# flange ratings suitable for most applications.
 ② Standard gasket for 600# and above flange ratings suitable for most applications.
 ③ Winding material matches chamber material.
 ④ Ring type gasket material matches flange material.

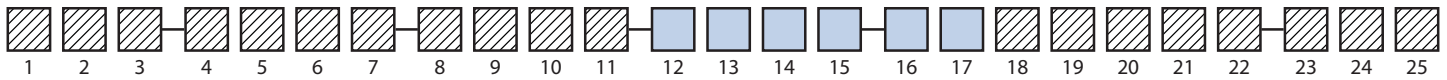

12 | VENT SIZE

14 | DRAIN SIZE

1	1/2"
2	3/4"
3	1"
4	1 1/2"
5	2"
6	2 1/2"
7	3"
8	4"
N	None

13 | VENT TYPE

15 | DRAIN TYPE

1	FNPT w/ Hex Head Plug (std.)
2	Socketweld
3	Male Threaded (MNPT)
4	Plain-End Nipple
5	Buttweld Nipple
6	RF Slip On Flange
7	RF Weld Neck Flange
8	RTJ Slip On Flange
9	RTJ Weld Neck Flange

A	Ball Valve, FNPT x FNPT
B	Ball Valve, SW x SW
C	Ball Valve, SW x FNPT
D	Gate Valve, FNPT x FNPT
E	Gate Valve, SW x SW
F	Gate Valve, SW x FNPT

N	None
---	------

16 | ACCESSORY / TECHNOLOGY CODE ①

N	None
---	------

A	Jupiter Transmitter (Top Mount)
B	Jupiter Transmitter (Top Mount Offset)
C	Jupiter Transmitter (Top Mount Offset, High Temp. Bend)
D	Jupiter Transmitter (Bottom Mount)
E	Jupiter Transmitter (Bottom Mount Offset, High Temp. Bend)

F	Orion Electronic Switch (OES or ORS) clamp-mounted to chamber
G	Orion Electronic Switch (OES or ORS) with switch mount rod

1	Eclipse GWR with coaxial probe
2	Eclipse GWR with rigid single rod probe
3	Eclipse GWR with flexible single rod probe
4	Eclipse GWR with enlarged coaxial probe

L	OCT Reed Chain Transmitter (Top Mount)
M	OCT Reed Chain Transmitter (Bottom Mount)

① All accessories must be ordered separately. Consult the appropriate product literature.

17 | TEMPERATURE OPTIONS

N	None
---	------

Y	High-temp Insulation Pad for indicator only for process operating temperatures > 375°F (191°C)
---	--

A	High-Temp Insulation Blanket for temperatures up to 500 °F (260 °C) On Chamber Only
B	High-Temp Insulation Blanket for temperatures up to 1000 °F (538 °C) On Chamber Only
C	High-Temp Insulation Blanket for temperatures up to 500 °F (260 °C) On Chamber & Flanges
D	High-Temp Insulation Blanket for temperatures up to 1000 °F (538 °C) On Chamber & Flanges

T	High-Temp Insulation Pad for externally mounted Jupiter or OCT level transmitter. 165°F to 375°F (74° to 191° C)
V	High-Temp Insulation Pad for visual indicator and externally mounted Jupiter level transmitter. 376°F to 850°F (192° to 454° C)
W	High-Temp Insulation Pad for Indicator and externally mounted OCT level transmitter. 376°F to 425°F (192° to 218° C)

L	Cryogenic Insulation for temperatures down to -150 °F (-101 °C)
P	Cryogenic Insulation for temperatures down to -320 °F (-196 °C)

H	Electric Heat Tracing with insulation blanket
S	Steam Tracing, 3/8" tubing with insulation blanket
J	Steam Jacket with 1/2" NPT inlet/outlet (customer to provide steam operating pressure and temperature)

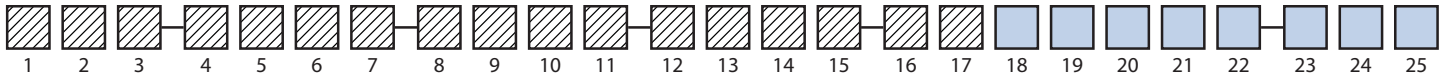

18 MEASUREMENT TYPE & INDICATOR STYLE

Total Level Measurement	
S	Fluorescent Orange Shuttle / Follower
1	Orange / Black Flags
2	Yellow / Black Flags
3	Red / White Flags
4	Red / Silver Flags

A	Orange / Black Flags with Yellow Float Diagnostics ⓘ
B	Yellow / Black Flags with Orange Float Diagnostics ⓘ
C	Red / White Flags with Yellow Float Diagnostics ⓘ
D	Red / Silver Flags with Green Float Diagnostics ⓘ

N	No Indicator (For use with Jupiter external cage)
---	---

Interface Level Measurement	
T	Fluorescent Orange Shuttle / Follower
5	Orange / Black Flags
6	Yellow / Black Flags
7	Red / White Flags
8	Red / Silver Flags

F	Orange / Black Flags with Yellow Float Diagnostics ⓘ
G	Yellow / Black Flags with Orange Float Diagnostics ⓘ
H	Red / White Flags with Yellow Float Diagnostics ⓘ
J	Red / Silver Flags with Green Float Diagnostics ⓘ

ⓘ Float diagnostics is a safety feature which indicates a contrasting color on the visual indicator when the float has fallen below the lowest measurable point on the scale. This can occur when the specific gravity of the liquid drastically decreases or the float collapses due to a pressure spike. (see pg. 4)

19 INDICATOR HOUSING MATERIAL & SCALE

Standard Anodized Aluminum Housing	
1	Foot / Inch Measurement
2	Meter / Centimeter Measurement
3	Running Inch Measurement
4	Percent (0 - 100%) Measurement
5	Gallon Measurement
6	Liter Measurement

N	No scale
---	----------

Optional Stainless Steel Housing	
A	Foot / Inch Measurement
B	Meter / Centimeter Measurement
C	Running Inch Measurement
D	Percent (0 - 100%) Measurement
E	Gallon Measurement
F	Liter Measurement

P	No scale
---	----------

20, 21, 22 FACTORY ASSIGNED

X X X	These codes are factory assigned.
-------	-----------------------------------

23, 24, 25 CENTER-TO-CENTER PROCESS CONNECTION DIMENSION & VISUAL INDICATION LENGTH

X X X	Specify in INCHES when model code 2 is E Specify in CENTIMETERS when model code 2 is M
	Example #1 : Center-to-Center is 84 inches. Enter as 084. Example #2 : Center-to-Center is 124 centimeters. Enter as 124. Example #3 : Center-to-Center is 124.25 inches. Enter as 124 centimeters and X the model for 124.25 cm. Or consult factory for assistance. Example #4 : Center-to-Center is 724 millimeters. Enter as 072 centimeters and X the model for 724 millimeters. Or consult factory for assistance.

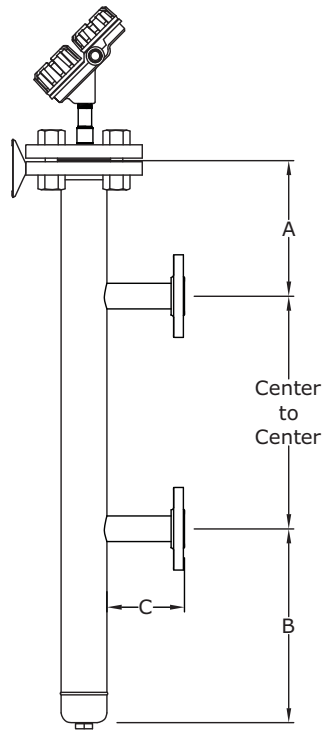

Configuration 2 & B

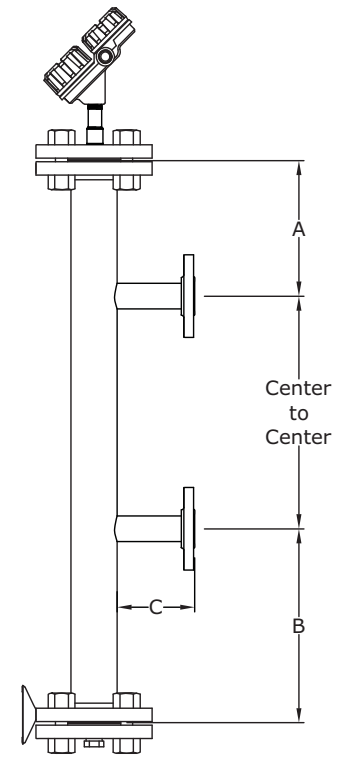

Configuration 3 & C

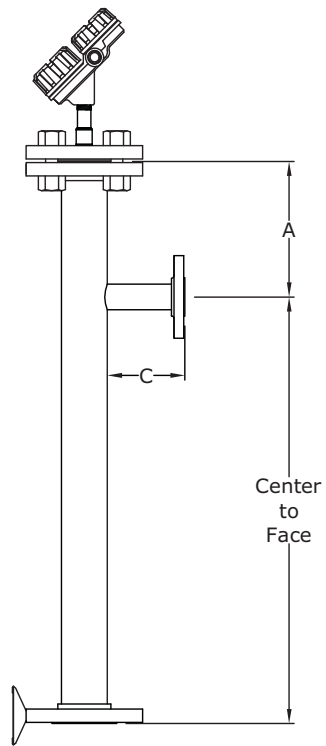

Configuration 8 & H

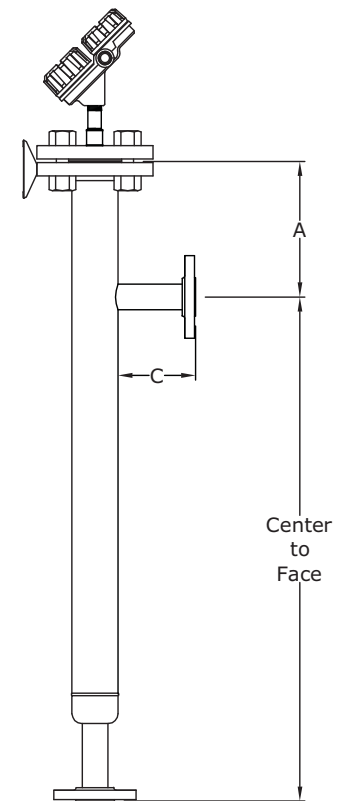

Configuration 9 & J

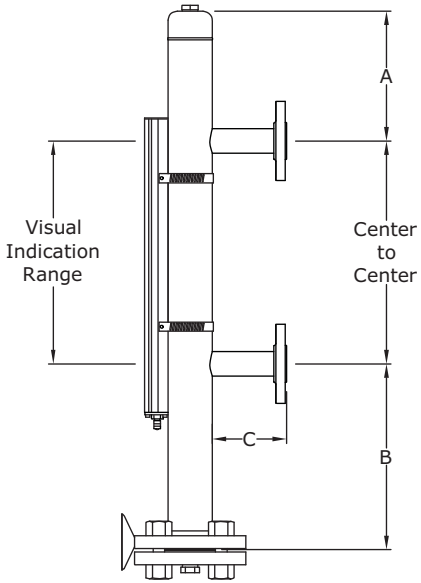

Configuration 1

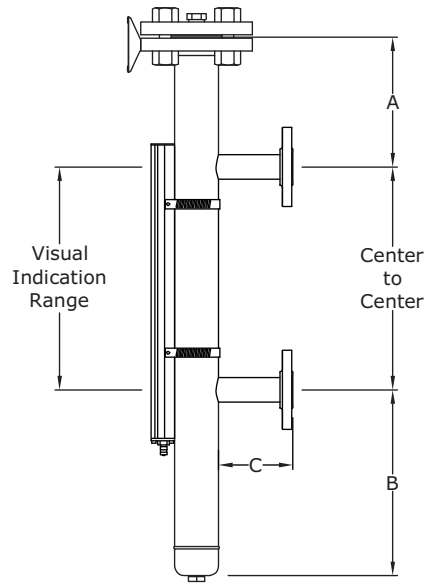

Configuration 2

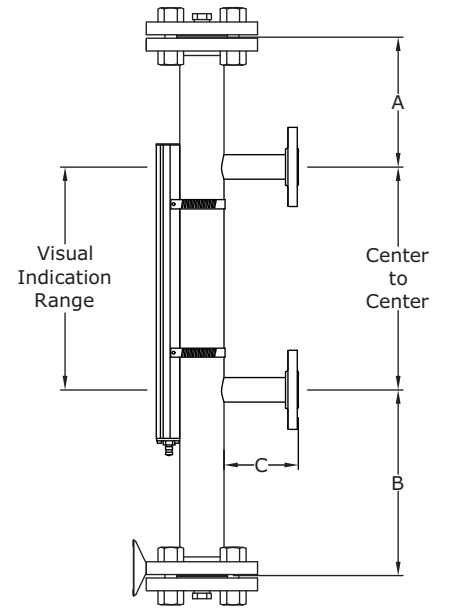

Configuration 3

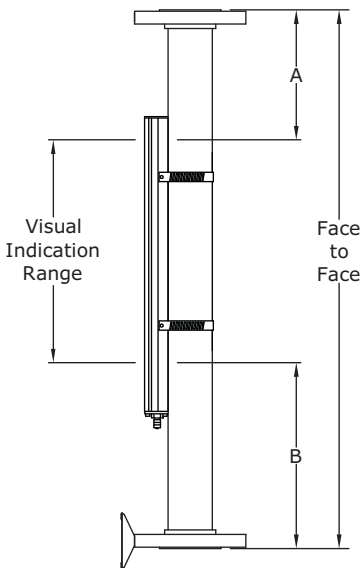

Configuration 4

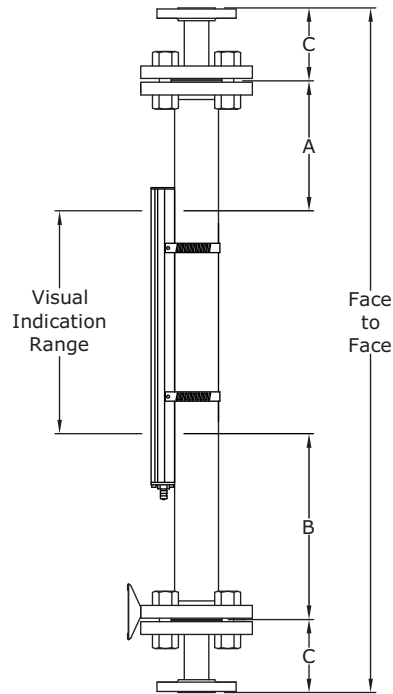

Configuration 5

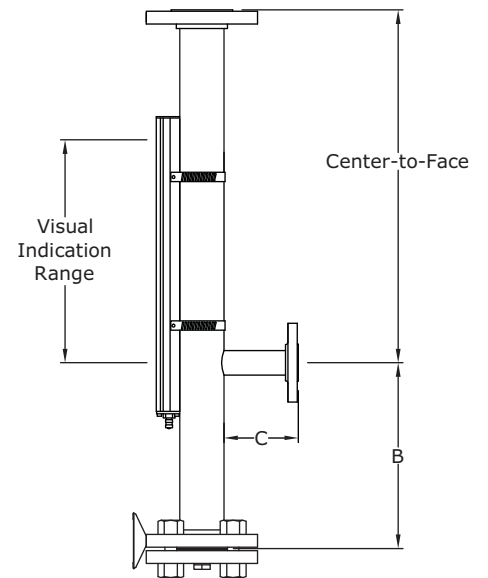

Configuration 6

All dimensions vary depending on application parameters and/or accessory items. Dimensional drawings are available by contacting the factory.

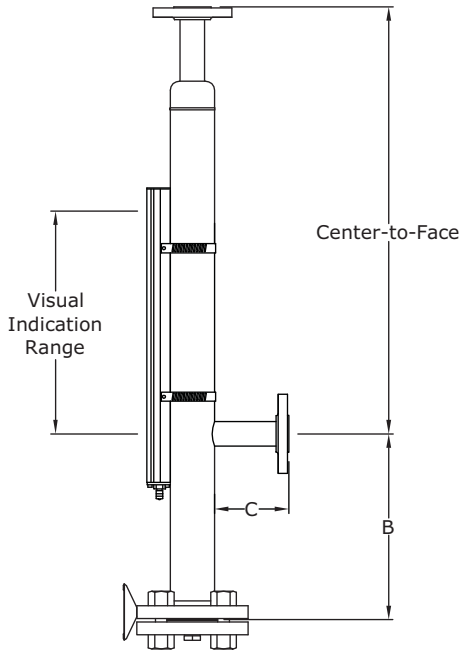

Configuration 7

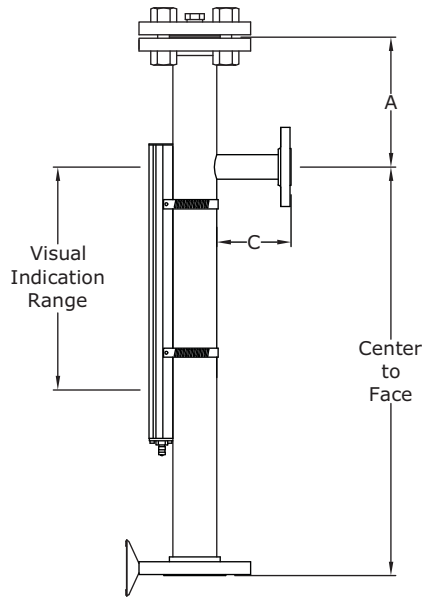

Configuration 8

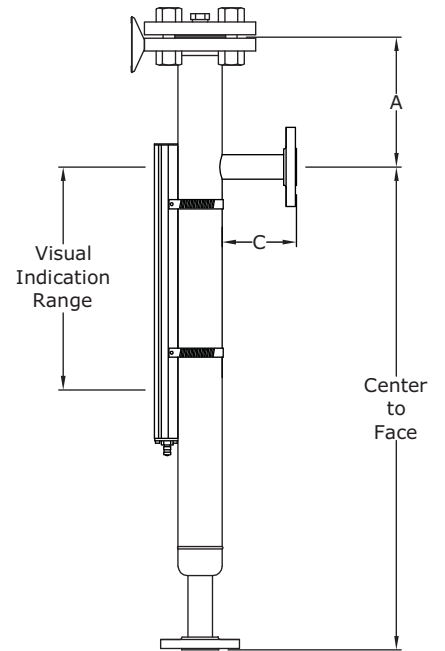

Configuration 9

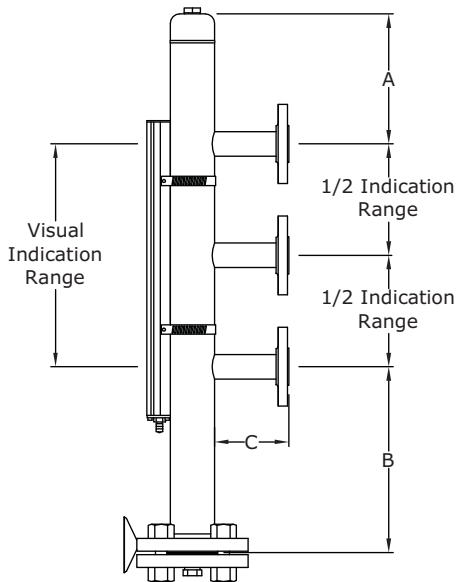

Multiple Process Connections
consult factory

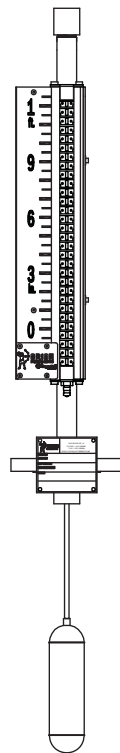

Atlas Top Mount
configuration T

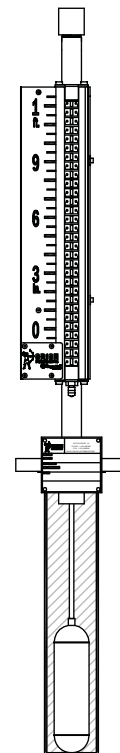

Atlas Top Mount
w/stilling well
consult factory

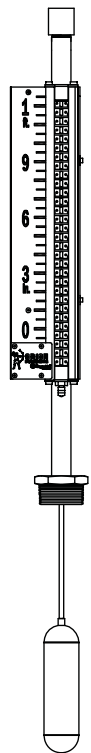

Atlas Top Mount
w/threaded process
connection
consult factory

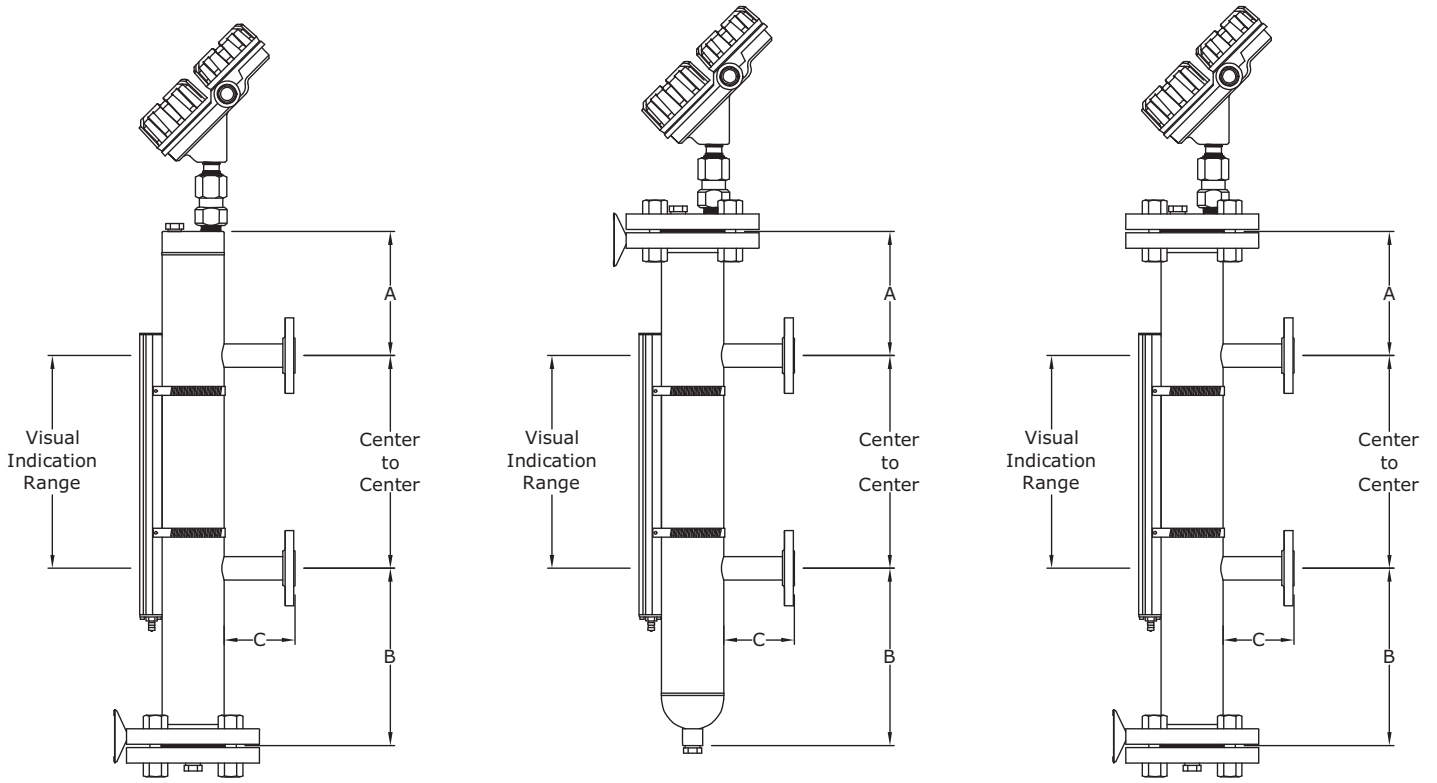

Configuration 1

Configuration 2

Configuration 3

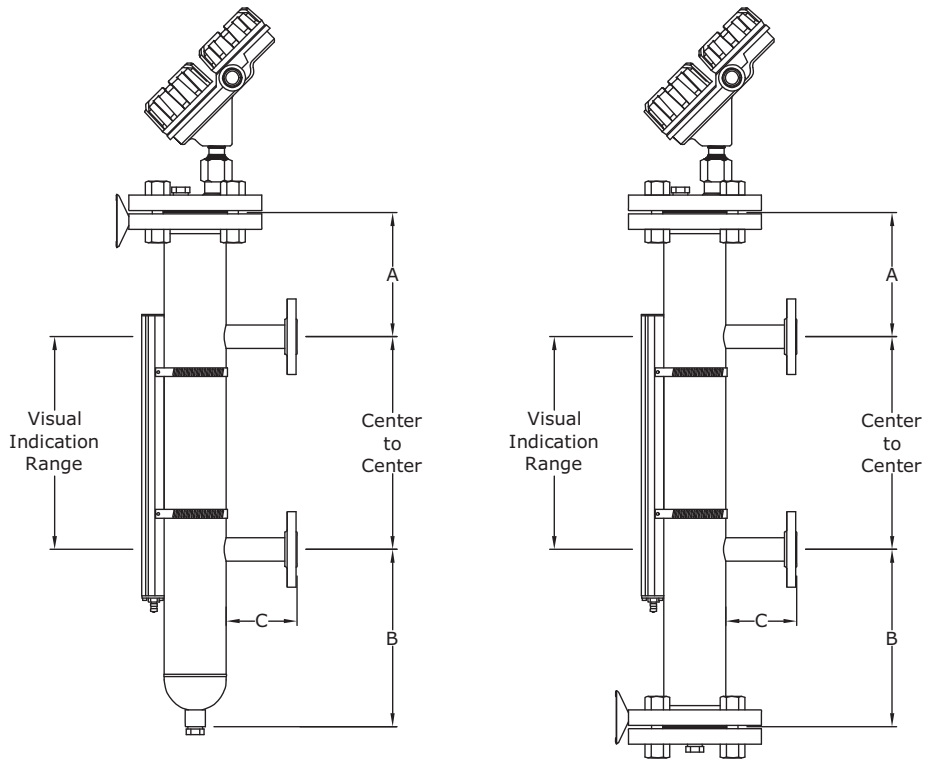

Configuration 4

Configuration 5

All dimensions vary depending on application parameters and/or accessory items. Dimensional drawings are available by contacting the factory.

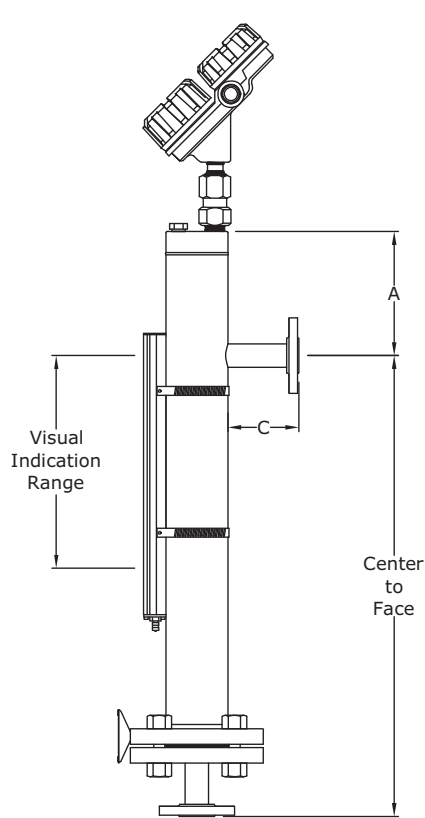

Configuration A

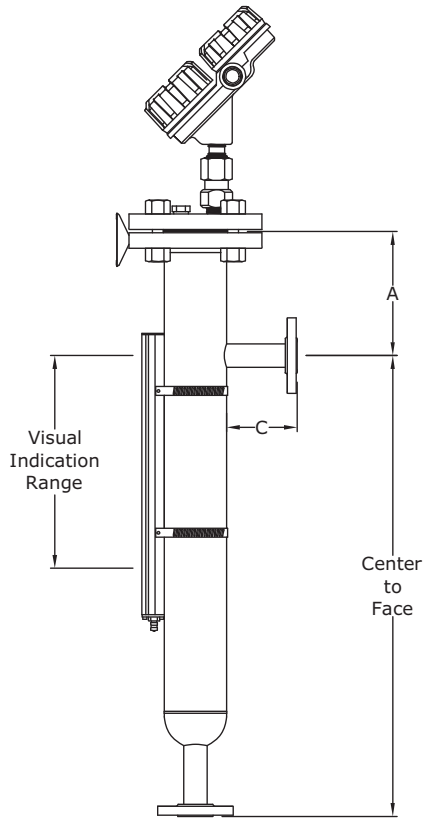

Configuration B

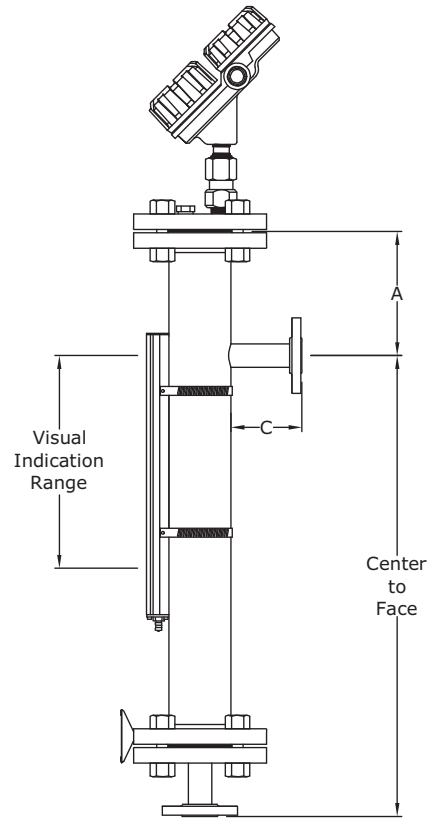

Configuration C

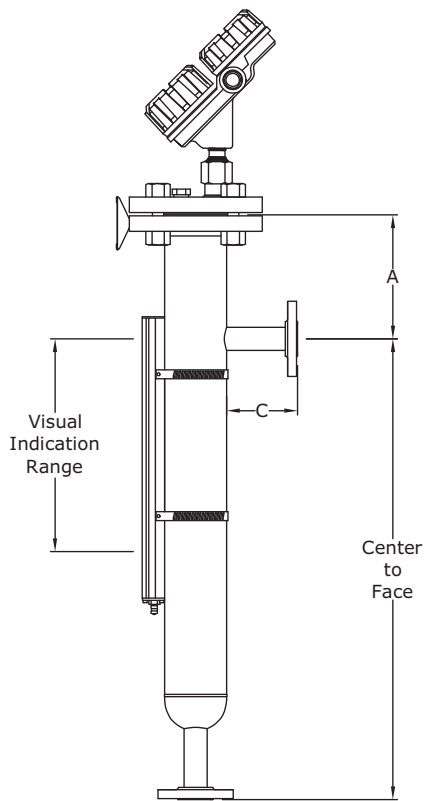

Configuration D

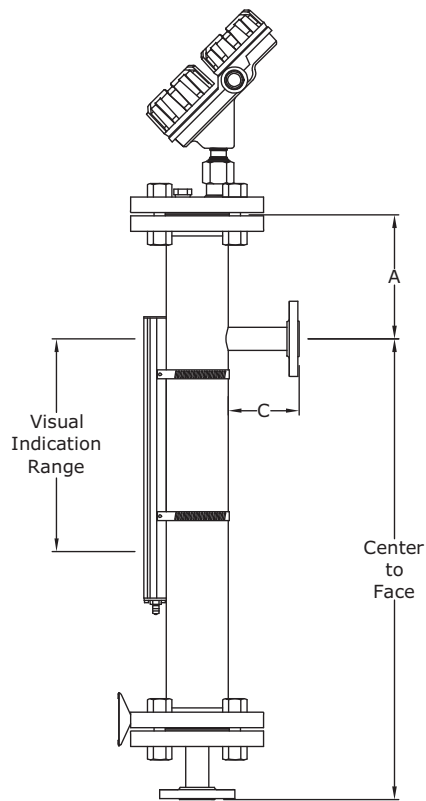

Configuration F

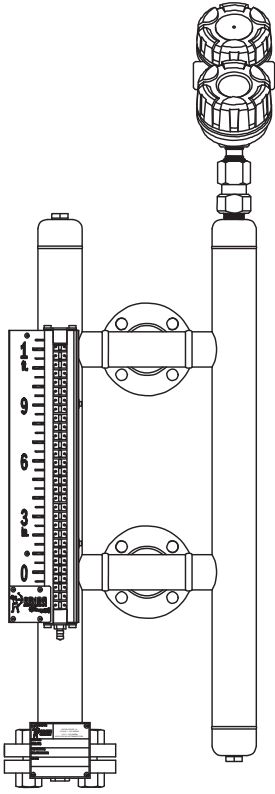

Configuration 1

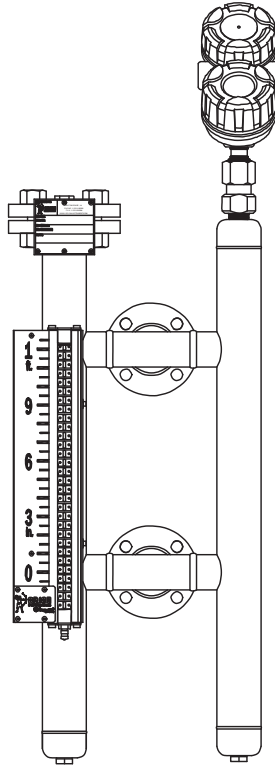

Configuration 2

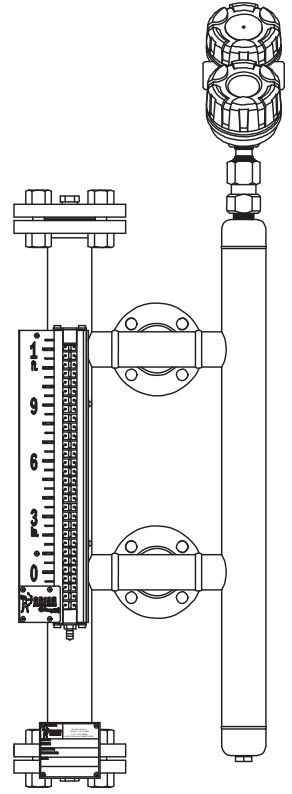

Configuration 3

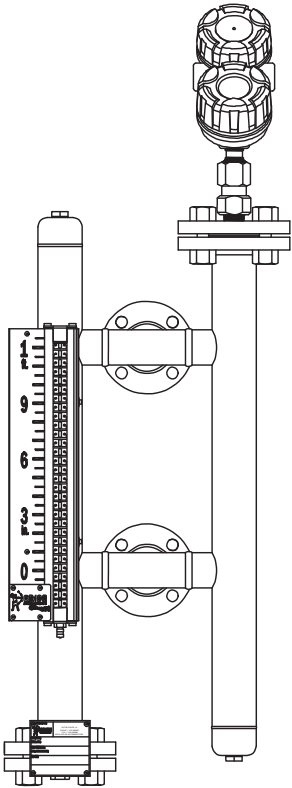

Configuration 4

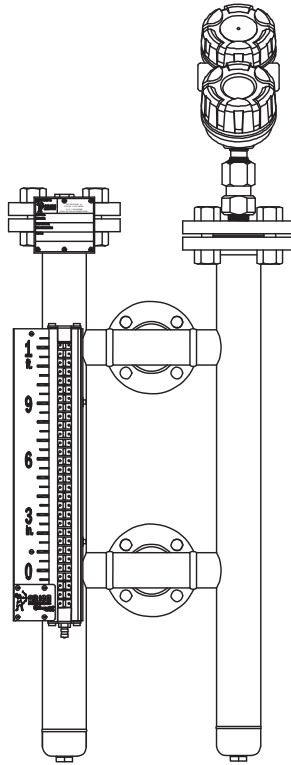

Configuration 5

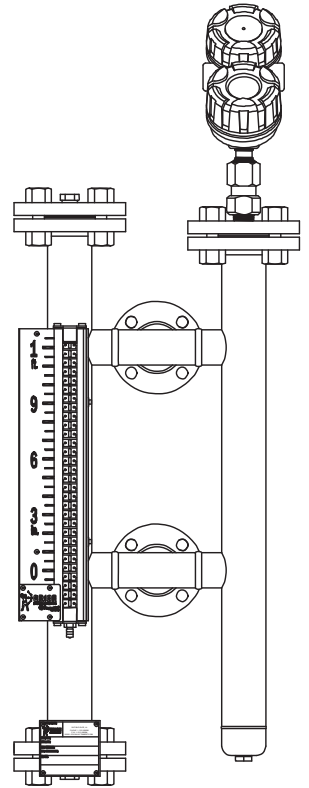

Configuration 6

All dimensions vary depending on application parameters and/or accessory items. Dimensional drawings are available by contacting the factory.

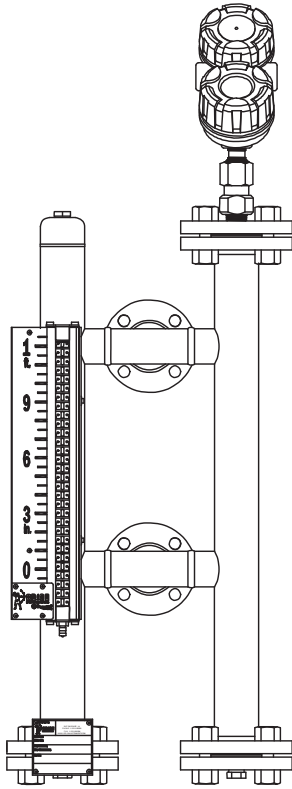

Configuration 7

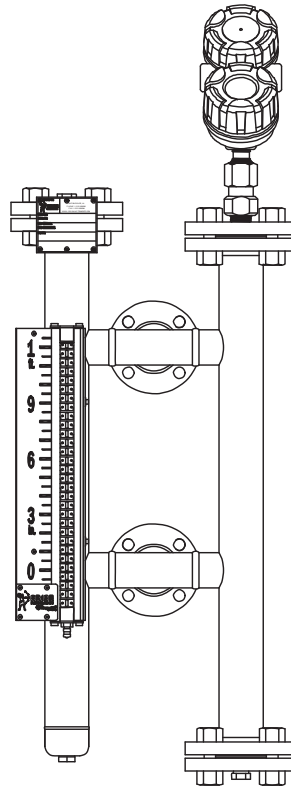

Configuration 8

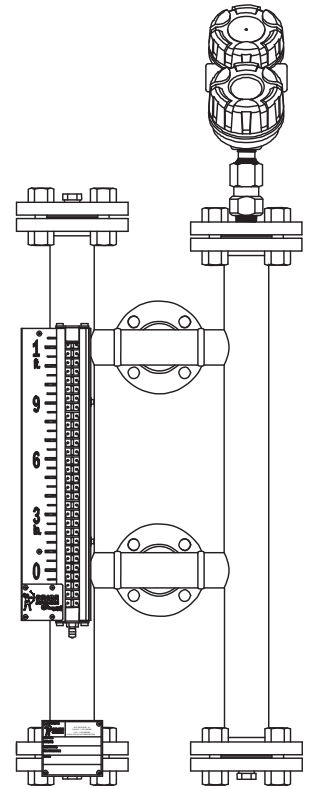

Configuration 9

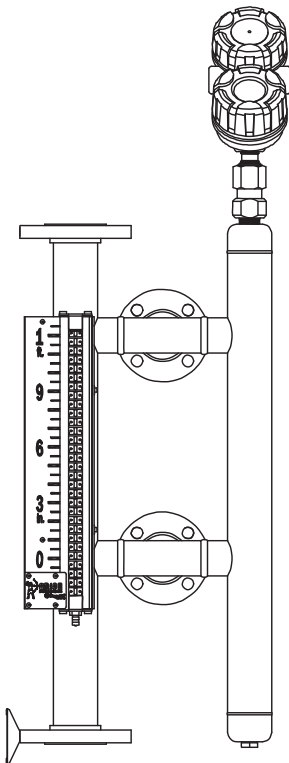

Configuration A

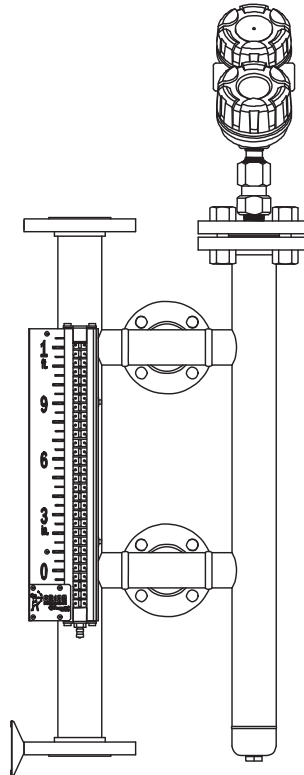

Configuration B

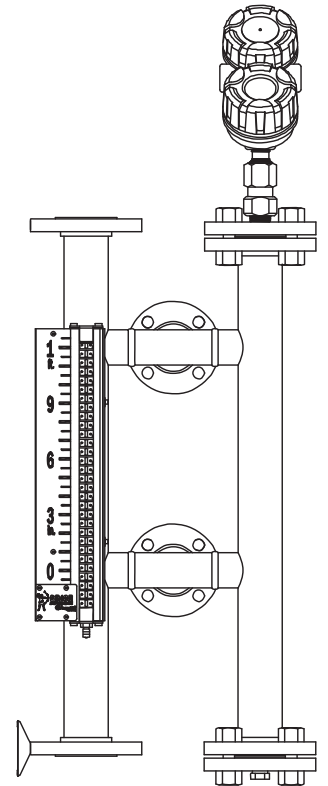

Configuration C

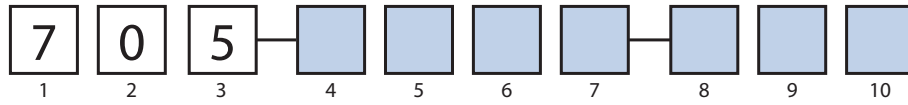

1, 2, 3 | BASIC MODEL

705	Eclipse Guided Wave Radar Level Transmitter
-----	---

4 | POWER

5	24 VDC, Two-wire
---	------------------

5, 6 | SIGNAL OUTPUT & ELECTRONICS

1 0	4-20 mA with HART - SIL 1 standard electronics (SFF: 85.4%)
1 A	4-20 mA with HART - SIL 2 enhanced electronics (SFF: 91%)
2 0	FOUNDATION fieldbus™ Communication
3 0	PROFIBUS PA™ Communication

7 | ACCESSORIES

0	No digital display and keypad
A	Digital display and keypad

8 | MOUNTING / CLASSIFICATION

1	Integral, General Purpose & Intrinsically Safe (FM & CSA) , Non-incendive (Class I, Div. 2)
2	Remote, General Purpose & Intrinsically Safe (FM & CSA) , Non-incendive (Class I, Div. 2)
3	Integral, Explosion Proof (FM & CSA) & Non-incendive
4	Remote, Explosion Proof (FM & CSA) & Non-incendive
A	Integral, General Purpose & Intrinsically Safe (ATEX & JIS EEx ia IIC T4)
B	Remote, General Purpose & Intrinsically Safe (ATEX & JIS EEx ia IIC T4)
C	Integral, Explosion Proof (ATEX & JIS EEx d [ia] IIC T6) (must be ordered with Conduit Connection Codes 0 and 1)
D	Remote, Explosion Proof (ATEX & JIS EEx d [ia] IIC T6) (must be ordered with Conduit Connection Codes 0 and 1)
E	Integral, Non-incendive (ATEX EEx n II T4..6)
F	Remote, Non-incendive (ATEX EEx n II T4..6)

9 | HOUSING

1	Cast aluminum, dual compartment, 45° angle
2	316 SS, dual compartment, 45° angle
7	Cast aluminum, dual compartment, 45° angle, 12-ft remote
8	316 SS, dual compartment, 45° angle, 12-ft remote ①

10 | CONDUIT CONNECTION

0	¾" NPT
1	M20

① To reduce the possibility of probe damage due to vibration, it is recommended to use a remote mount transmitter (Mounting/Classification codes 2, 4, B, D, or F) when ordering the heavier 316 SS version.

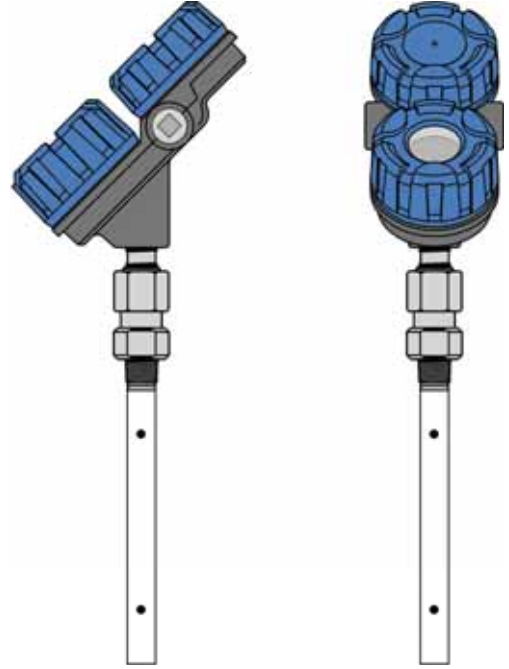

Eclipse with threaded process fitting

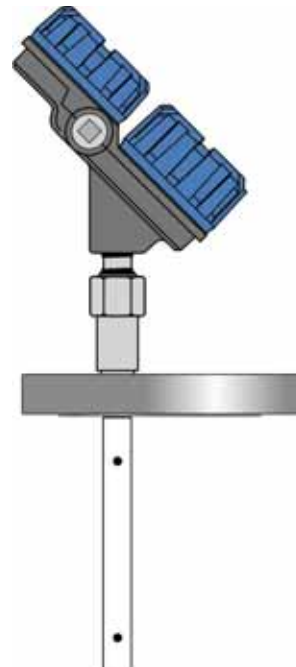

Eclipse transmitter with probe offset for Aurora MLI

ECLIPSE PROBE SPECIFICATIONS

Coaxial Probe Type	Basic Model	Maximum Pressure	Maximum Temperature	Minimum Temperature	Dielectric Range	Length ①
Overfill probe	7 x R	1000 psig @ +70° F (70 bar @ +20° C)	+400° F @ 270 psig (+200° C @ 18 bar)	-40° F @ 1000 psig (-40° C @ 50 bar)	1.4 to 100	24" to 240" (60 to 610 cm)
Overfill probe w/flushing port	7 x M	1000 psig @ +70° F (70 bar @ +20° C)	+400° F @ 270 psig (+200° C @ 18 bar)	-40° F @ 1000 psig (-40° C @ 50 bar)	1.4 to 100	24" to 240" (60 to 610 cm)
High Temp / High Pressure	7 x D	6250 psig @ +70° F (431 bar @ +20° C)	+800° F @ 2000 psig (+427° C @ 133 bar)	-320° F @ 6250 psig (-195° C @ 430 bar)	1.4 to 100	24" to 240" (60 to 610 cm)
Hi-Temp / Hi-Press w/flushing port	7 x L	6250 psig @ +70° F (431 bar @ +20° C)	+800° F @ 2000 psig (+427° C @ 133 bar)	-320° F @ 6250 psig (-195° C @ 430 bar)	1.4 to 100	24" to 240" (60 to 610 cm)
Steam Service	7 x S	2400 psig @ +650° F (165 bar @ +343 C) Saturated Steam	+650° F @ 2400 psig (+343 C @ 165 bar) Saturated Steam	N/A	10 to 100	24" to 180" (60 to 455 cm)
Interface Level	7 x T	1000 psig @ +70° F (70 bar @ +20° C)	+400° F @ 270 psig (+200° C @ 18 bar)	-40° F @ 1000 psig (-40° C @ 70 bar)	Upper: 1.4 to 5 Interface: 15 to 100	24" to 240" (60 to 610 cm)
Interface probe w/ flushing port	7 x N	1000 psig @ +70° F (70 bar @ +20° C)	+400° F @ 270 psig (+200° C @ 18 bar)	-40° F @ 1000 psig (-40° C @ 70 bar)	Upper: 1.4 to 5 Interface: 15 to 100	24" to 240" (60 to 610 cm)

Single Rod Probe Type	Probe 3rd Digit	Maximum Pressure	Maximum Temperature	Minimum Temperature	Dielectric Range	Length
Rigid	7 x J	3000 psig @ +70° F (207 bar @ +20° C)	+600° F @ 1600 psig (+316° C @ 110 bar)	0° F @ 3000 psig (-18° C @ 207 bar)	1.9 to 100	24" to 240" (60 to 610 cm)
Flexible	7 x 1	1000 psig @ +70° F (70 bar @ +20° C)	+300° F @ 400 psig (+150° C @ 27 bar)	0° F @ 1000 psig (-15° C @ 70 bar)	1.9 to 100	24" to 240" ① (60 to 610 cm)

① Consult factory for longer probe lengths

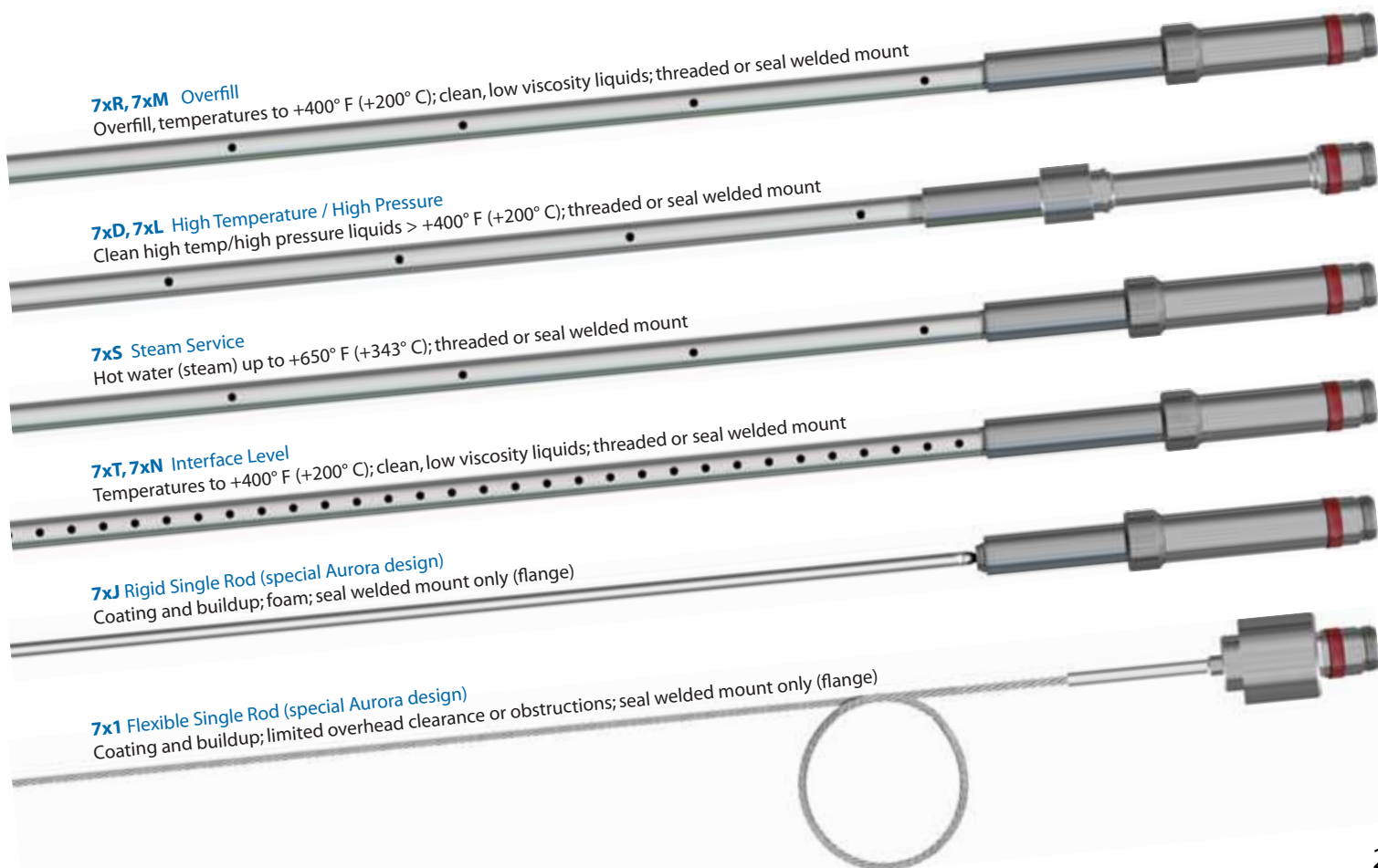

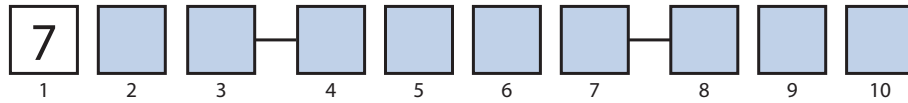

1,2 BASIC MODEL

7E	Eclipse GWR probe, English unit of measure
7M	Eclipse GWR probe, Metric unit of measure

The Aurora® MLI utilizes Magnetrol’s Eclipse® GWR level transmitter. All probes specified for an Aurora® should be selected from this model number. Consult factory for special requests.

3 PROBE TYPE

R	Coaxial	Overfill	minimum ¾" process connection (threaded or seal welded)	Media dielectric range ≥ 1.4 (2.0 with ceramic spacers)
M	Coaxial	Overfill w/flushing connection		
D	Coaxial	Hi-Temp/Hi-Pressure		
L	Coaxial	Hi-Temp/Hi-Pressure w/flushing connection		
S	Coaxial	Hot water/steam service		
T	Coaxial	Interface		
N	Coaxial	Interface w/flushing connection		
J	Single Rod	Hi-Temp, Rigid probe	seal welded process connection only	Media dielectric range ≥ 1.9
1	Single Rod	Flexible probe		

4 MATERIAL OF CONSTRUCTION

Seal Welded Probe & Flange Material	
Z	316/316L SS probe with carbon steel flange
Y	316/316L SS probe
T	Hastelloy C276 (probe types R, M, T, N, D, and L)
U	Monel (probe types R, M, T, N, D, and L)

Threaded Probe Material	
A	316/316L SS probe
B	Hastelloy C276 (probe types R, M, T, N, D, and L)
C	Monel (probe types R, M, T, N, D, and L)

5,6 PROCESS CONNECTION - SIZE / TYPE

Threaded	
11	¾" NPT threaded connection

3" ANSI Flanges	
53	3" 150# RF ANSI Flange
54	3" 300# RF ANSI Flange
55	3" 600# RF ANSI Flange
56	3" 900# RF ANSI Flange
57	3" 1500# RF ANSI Flange
58	3" 2500# RF ANSI Flange

4" ANSI Flanges	
63	4" 150# RF ANSI Flange
64	4" 300# RF ANSI Flange
65	4" 600# RF ANSI Flange
66	4" 900# RF ANSI Flange
67	4" 1500# RF ANSI Flange
68	4" 2500# RF ANSI Flange

7 PROCESS SEAL - O-RING MATERIAL

0	Viton® GFLT - universal use
2	Kalrez® 4079 - for aggressive media
8	Aegis PF128 - for steam and NACE applications
N	Borosilicate seal - for non-steam applications

8,9,10 INSERTION LENGTH

XXX	24 to 240 inches (60 to 610 cm) ①
	Example: 24 inches = 024; 160 centimeters = 160

① consult factory for insertion lengths less than 24" (60 cm) or greater than 240" (610 cm)

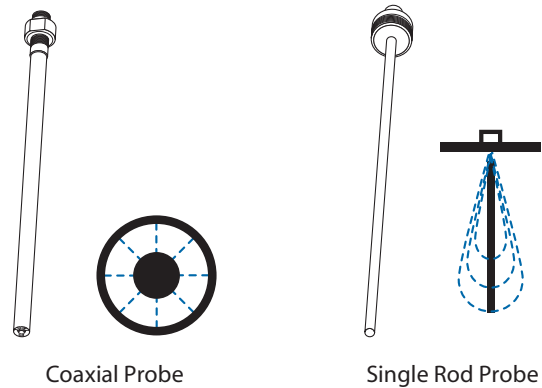

See Magnetrol bulletin 57-101 for additional information regarding Eclipse guided wave radar specifications.

Consult factory for special probe options including:

- NACE construction
- ASME construction
- Enlarged coaxial
- Custom spacers
- Special requests

Eclipse® Guided Wave Radar

The Enhanced Eclipse Model 705 is a loop-powered, 24 VDC, level transmitter based upon the revolutionary Guided Wave Radar (GWR) technology. GWR offers effective and reliable level indication by pulsing high-frequency microwave energy down a waveguide. Once the energy reaches the liquid surface, an impedance mismatch creates a reflection that is detected by the onboard electronics. Eclipse boasts an impressive accuracy specification of ± 0.10 inches and has proven to be effective in hundreds of applications common around the world. This single transmitter can be used with all probe types and offers enhanced reliability, as demonstrated by a Safe Failure Fraction of 91%.



Modulevel® Displacer Controller

The Digital E3 Modulevel is an advanced, intrinsically safe two-wire instrument utilizing simple buoyancy principle to detect and convert liquid level changes into a stable 4–20 mA output signal. The linkage between the level sensing element and output electronics provides a simple mechanical design and construction.



Kotron® RF Capacitance

The Kotron Model 801 Transmitter is a new generation RF Capacitance multi-function transmitter that offers the user unparalleled power. The preamplifier circuit provides installation flexibility of a 2500 feet maximum remote distance. The Model 801 can interface with two separate vessels, essentially making it a mini-multiplexer, while software mathematics allow for the sum or differential of the two signals.



Jupiter® Magnetostrictive

The Enhanced Jupiter Magnetostrictive level transmitter provides a 4–20 mA output proportional to the level being measured or FOUNDATION fieldbus™ output. Jupiter is available as an externally mounted model for use with Orion Atlas™, Gemini™, and Aurora® magnetic level indicators or as a direct insertion version for use in a wide variety of process vessels or external chambers.



Digits 1 through 8 (See next page for digits 11 through 15)

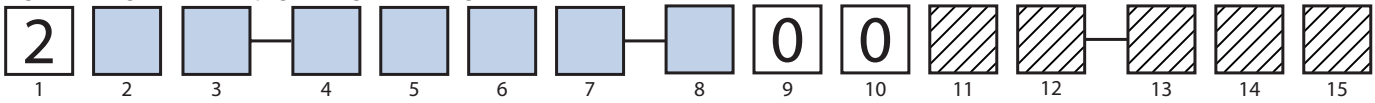

1 | PRODUCT SELECTION

2	Jupiter Magnetostrictive Level Transmitter
---	--

2 | OUTPUT

4	HART®, 4-20 mA, LCD Display, SIL 1
5	FOUNDATION fieldbus™, LCD Display
6	HART®, 4-20 mA, LCD Display, SIL 2
7	Two level tracking, HART utilizing two MLI floats
8	Two level tracking, FOUNDATION fieldbus™ utilizing two MLI floats

3 | HOUSING AND CONDUIT ENTRY

1	Cast Aluminum, Integral Mount with 3/4" NPT Conduit Entry
2	Cast Aluminum, Integral Mount with M20 Conduit Entry
3	316 SS, Integral Mount with 3/4" NPT Conduit Entry
4	316 SS, Integral Mount with M20 Conduit Entry

4 | AREA CLASSIFICATION

1	FM/CSA, Intrinsically Safe, Non-Incendive
3	FM/CSA, Explosion Proof, Non-Incendive
A	ATEX, Ex d IIC T6, Flameproof
E	ATEX, Ex ia IIC T4, Intrinsically Safe
J	IEC, Ex d IIC T6, Flameproof
K	IEC, Ex ia IIC T4, Intrinsically Safe
L	INMETRO, Ex d IIC T6, Flameproof
M	INMETRO, Ex ia IIC T4, Intrinsically Safe

5 | CONFIGURATION

E	Top Mount, Material Code 1 only
F	Top Mount Offset, Material Code 1 only
G	Top Mount Offset, High Temperature, Material Code A only
H	Bottom Mount Offset, Material Code 1 only
J	Bottom Mount Offset, High Temperature, Material Code A only

6-7 | MOUNTING LOCATION

00	External Mount on MLI or Chamber, Left Side (standard)
01	External Mount on MLI or Chamber, Right Side

8 | PROBE MATERIAL OF CONSTRUCTION

1	316/316L SS (standard), +250° F (+120° C) Maximum
A	316/316L SS (high temp), +500° F (+260° C) Maximum +850° F (+454° C) with factory-installed fiberglass insulation

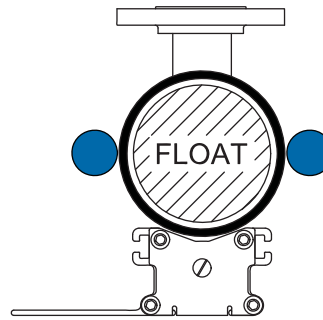

Probe mounting positions on Atlas™, Stratus™, and Gemini™ MLI

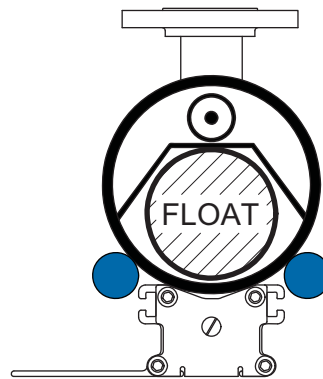

Probe mounting positions on Aurora® MLI
Probe proximity to the float is critical

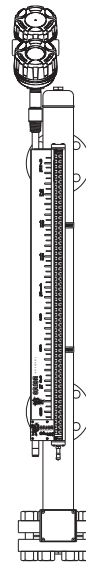

Left side mount (standard)

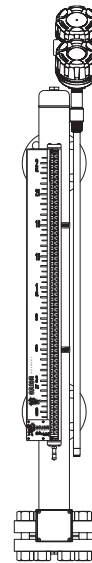

Right side mount

Note: When specifying the mounting location, be aware of other accessories that may also mount on the MLI (i.e. switches, heat tracing, etc). Choose left side mount whenever possible.

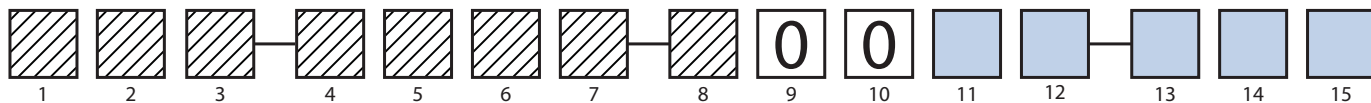

11 | CHAMBER MOUNTING CODE

Without High-Temp Chamber Insulation		With High-Temp Chamber Insulation	
1	MLI model code digit 20 is 1, 2, or 7	E	MLI model code digit 20 is 1, 2, or 7
2	MLI model code digit 20 is 3, 4, 5 or 6	F	MLI model code digit 20 is 3, 4, 5 or 6
3	MLI model code digit 20 is A, B, C, or D	G	MLI model code digit 20 is A, B, C, or D
4	MLI model code digit 20 is E, F, G, H, or J	H	MLI model code digit 20 is E, F, G, H, or J
5	MLI is a Top Mount design	J	MLI is a Top Mount design
0	None (if clamps already exist)	0	None (if clamps already exist)

12 | UNIT OF MEASURE

E	Probe length in English units (inches)
M	Probe length in Metric units (centimeters)

13-15 | PROBE LENGTH

XXX	Specify required probe length. See figures to the right.
-----	--

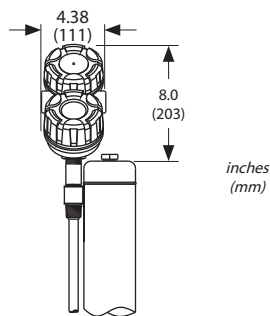

Top Mount

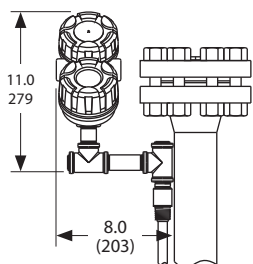

Top Mount Offset

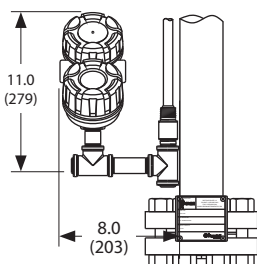

Bottom Mount Offset

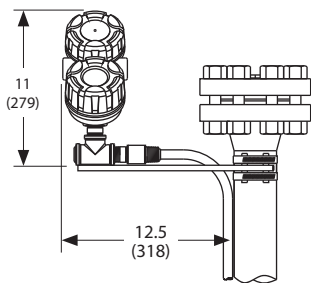

Top Mount Offset High Temperature

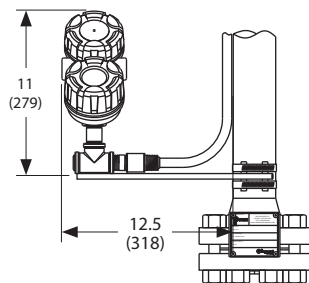

Bottom Mount Offset High Temperature

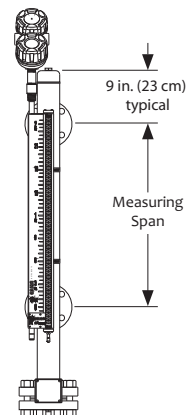

Top Mount Configuration

Probe Length = Center-to-Center + 8 in. (20 cm)

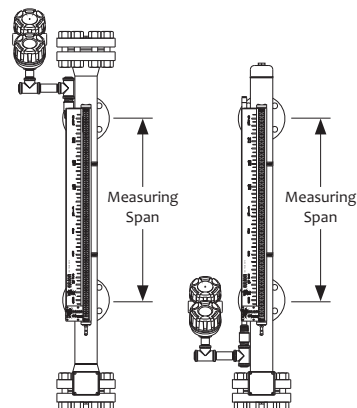

Top/Bottom Mount Offset Configuration

Probe Length = Center-to-Center + 6 in. (15 cm)

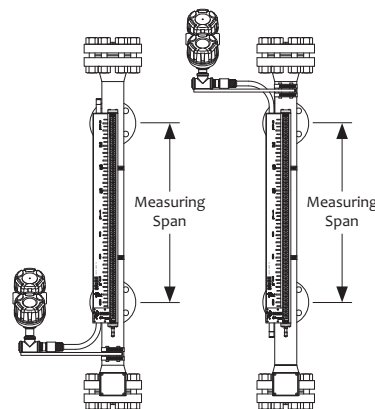

Hi-Temp Top/Bottom Mount Offset Configuration

Probe Length = Center-to-Center + 15 in. (38 cm)

OES 10-Amp DPDT Point Level Switch

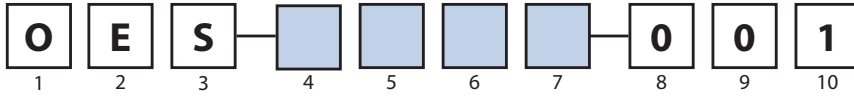

4 ENCLOSURE MATERIAL

A	Cast Aluminum
S	Stainless Steel

5 AGENCY APPROVAL

1	FM / CSA
---	----------

6 CHAMBER MOUNTING CODE

1	MLI model code digit 20 is 1, 2, or 7
2	MLI model code digit 20 is 3, 4, 5 or 6
3	MLI model code digit 20 is A, B, C, or D
4	MLI model code digit 20 is E, F, G, H, or J
5	MLI is a Top Mount design
N	No clamps required (for use with switch mount rod)

7 MOUNTING STYLE

C	Clamp mounted on MLI (standard)
P	Clamp mounted on MLI with insulation pad
R	Attached to switch mount rod

Designed for optimal repeatability and reliability, the OES is actuated by simple magnetic coupling. As the liquid level moves, the MLI float follows. When the float moves into the proximity of the snap switch, the switch magnet interacts with the float’s magnetic field actuating the switch.

see Orion bulletin *OES-100* for more information



Model: OES

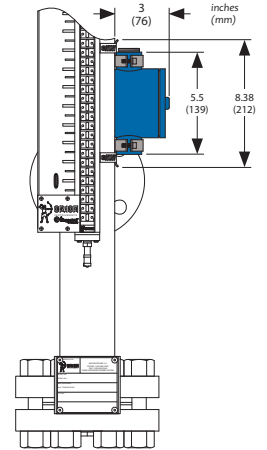

Physical Dimensions

ORS 1-Amp SPDT Point Level Switch

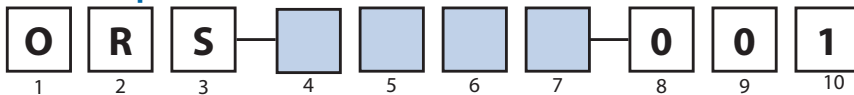

4 ENCLOSURE

1	Standard stainless body without junction box
A	Option 1 with cast aluminum junction box
S	Option 1 with stainless steel junction box

5 AGENCY APPROVAL

1	FM / CSA
A	ATEX

6 CHAMBER MOUNTING CODE

1	MLI model code digit 20 is 1, 2, or 7
2	MLI model code digit 20 is 3, 4, 5 or 6
3	MLI model code digit 20 is A, B, C, or D
4	MLI model code digit 20 is E, F, G, H, or J
5	MLI is a Top Mount design
N	No clamps required (for use with switch mount rod)

7 MOUNTING STYLE

C	Clamp mounted on MLI (standard)
P	Clamp mounted on MLI with insulation pad
R	Attached to switch mount rod

The **Model ORS** reed switch is available to augment the control capabilities of Orion’s extensive line of magnetic level indicators.

Housed in an explosion proof enclosure, the ORS mounts to the outside of the MLI via clamps. This mounting style allows addition or repositioning of switches at any time, without disruption of the process.

see Orion bulletin *ORS-300* for more information



Model: ORS
(shown with optional aluminum junction box)

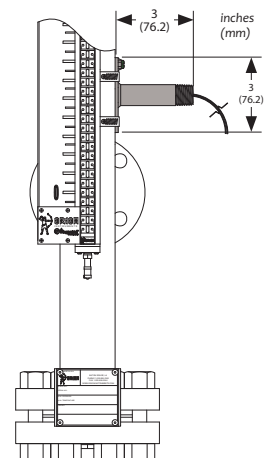

Physical Dimensions

OCT Reed Chain Transmitter

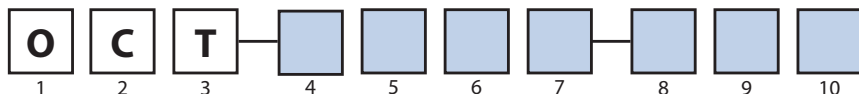

The **OCT** analog transmitter mounts directly to the side of the Atlas, Aurora or Gemini chamber, and provides a continuous 4–20 mA output signal proportional to liquid level. Using simple and reliable reed switches surface mounted to a printed circuit board, the unit provides level accuracy of ±0.50" (13 mm). Activated by the field of the float magnets, the transmitter is totally non-invasive and designed for years of maintenance free service.

see Orion bulletin *OCT-400* for more information

4 ENCLOSURE

A	Cast Aluminum
S	Stainless Steel

5 ENCLOSURE MOUNTING POSITION

T	Top mounted
B	Bottom mounted

6 CHAMBER MOUNTING CODE

No insulation present on MLI	
1	MLI model code digit 20 is 1, 2, or 7
2	MLI model code digit 20 is 3, 4, 5 or 6
3	MLI model code digit 20 is A, B, C, or D
4	MLI model code digit 20 is E, F, G, H, or J
5	¾" (for Atlas top mount configuration only)

High-temp insulation on MLI	
E	MLI model code digit 20 is 1, 2, or 7
F	MLI model code digit 20 is 3, 4, 5 or 6
G	MLI model code digit 20 is A, B, C, or D
H	MLI model code digit 20 is E, F, G, H, or J
J	¾" (for Atlas top mount configuration only)

7 UNIT OF MEASURE

E	Measuring length specified in inches
M	Measuring length specified in centimeters

8, 9, 10 MEASURING LENGTH

XXX	6" to 198" (15 cm to 503 cm)
	same as MLI center-to-center dimension

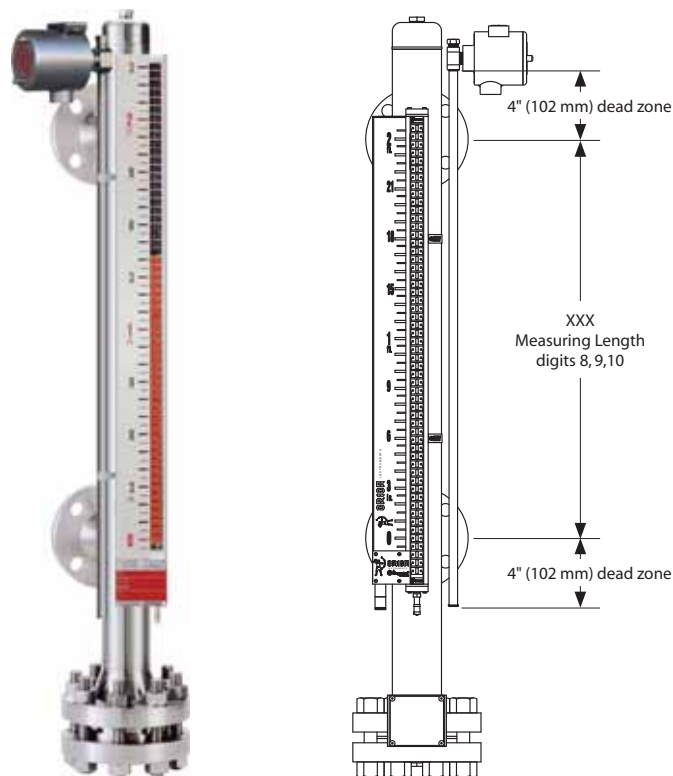

Model: OCT
(shown with optional stainless steel enclosure)

Probe dimensions

Field Service and Commissioning Support

Orion is equipped with a support network that stretches across the globe. We can provide on-site field service support, as well as remote technical assistance via phone or e-mail.

Although all Orion products are tested, calibrated, and configured at the factory, the presence of an expert field service technician during the commissioning of your new instrumentation can provide the added insurance that everything is set up specifically for each individual application.

For more information on our support services, please contact us.



An Orion technician operates PACTware on a drilling rig



Orion maintains competitive lead times for all of our products. If expedited shipping is required, we can accommodate your request.

To improve delivery on your order, contact your local *Orion Instruments* representative or contact us directly.



2105 Oak Villa Boulevard • Baton Rouge, Louisiana 70815 • 225-906-2343 • Toll Free 866-55-ORION (866-556-7466) • Fax 225-906-2344 • www.orioninstruments.com

Copyright © 2011 Orion Instruments, LLC. All rights reserved. Printed in the USA.

Performance specifications are effective with date of issue and are subject to change without notice.

Orion, Orion logotype, Magnetrol, Magnetrol logotype, Aurora, Jupiter, Eclipse, Modulevel, and Kotron are registered trademarks of Magnetrol International.

Atlas, Gemini, Stratus, and Insta-Seal are trademarks of Magnetrol International.

HART® is a registered trademark of the HART Communication Foundation.

FOUNDATION fieldbus™ is a trademark of Fieldbus Foundation.

Hastelloy® is a registered trademark of Haynes International.

Monel® is a registered trademark of the INCO family of companies.

Teflon® is a registered trademark of DuPont.

Halar® is a registered trademark of Solvay Solexis S.p.A.

Tri-Clamp® is a registered trademark of Ladish Company.