



ORION[®]
INSTRUMENTS

A  **Magnetrol** Company

THE NEXT GENERATION OF MAGNETIC LEVEL INDICATION

Jupiter[®]

MAGNETOSTRICTIVE LEVEL TRANSMITTER



DESCRIPTION

The Enhanced Jupiter Magnetostrictive level transmitter provides an analog or digital output proportional to the level being measured. Available communication protocols include HART®/4-20 mA and FOUNDATION fieldbus™. Jupiter is available as an externally mounted model for use with the Atlas™, Gemini™, and Aurora® magnetic level indicators or as a direct insertion version for use in a wide variety of process vessels or external chambers. A dual compartment housing allows for separation of wiring and electronics to help facilitate ease of installation and configuration for top mount, bottom mount, and direct insertion versions.

Jupiter supports the FDT/DTM standard. Each transmitter will ship with a CD containing the PACTware™ frame program including the entire Magnetrol / Orion Instruments DTM library and literature catalog. PACTware™ offers additional configuration and trending flexibility via the convenience of a personal computer connected to the instrument anywhere in loop.

TECHNOLOGY

The Enhanced Jupiter transmitter utilizes the engineering principle of magnetostriction and the effect of a magnetic field on the magnetostrictive wire as the basis for operation. The primary components

are the electronics assembly and the probe assembly containing the wire and sensor.

A low energy pulse which is produced by the electronics travels the length of the magnetostrictive wire. A return signal is generated from the precise location where the magnetic field of the float intersects the wire. An on-board clock measures the elapsed time between the generation of the pulse and the return of the mechanical signal. This is detected by the piezoelectric sensor located below the electronics housing. The firmware interprets the time-of-flight data and displays the process variable data resulting from the measurement.



PRINCIPLE OF OPERATION

- 

1 on-board electronics send a low-voltage electrical pulse down the magnetostrictive wire at the speed of light, ten times per second.
- 

2 magnets contained within the float focus their energy toward the wire at the precise location of the liquid level.
- 

3 interaction between the magnetic field, electrical pulse, and magnetostrictive wire cause a slight mechanical disturbance in the wire that travels back up the probe at the speed of sound.
- 

4 the mechanical wave is converted back into electrical energy by two piezoelectric crystals. The on-board electronics interpret the time-of-flight data and indicate the position of the float magnets.



Direct Insertion



Top Mount



Top Mount Offset



Bottom Mount Offset



**High Temperature
Top Mount Offset**



**High Temperature
Bottom Mount Offset**

PRODUCT FEATURES

- Precision level measurement $\pm 0.015"$ (.381 mm)
- Two-wire, loop-powered intrinsically safe and explosion proof level transmitter
- 4–20 mA output with HART®
- Optional FOUNDATION fieldbus™ output
- LCD with 3-key push-button standard
- High repeatability $\pm 0.005"$ (0.127 mm)
- Multi-variable transmitter able to measure level, interface level, and both simultaneously
- Maximum Process temperatures
 - Direct Insertion Model: +500° F (+260° C)
 - External Mount: +850° F (+455° C)
- -40° to +175° F (-40° to +80° C) ambient operation
- Lengths to 400 inches (999 centimeters)
- Third Party Safety Integrity Level (SIL) data (FMEDA analysis) for Safety Instrumented Systems engineering is available. HART® version is suitable for SIL 2 loops: Safe Failure Fraction (SFF) = 90.7%

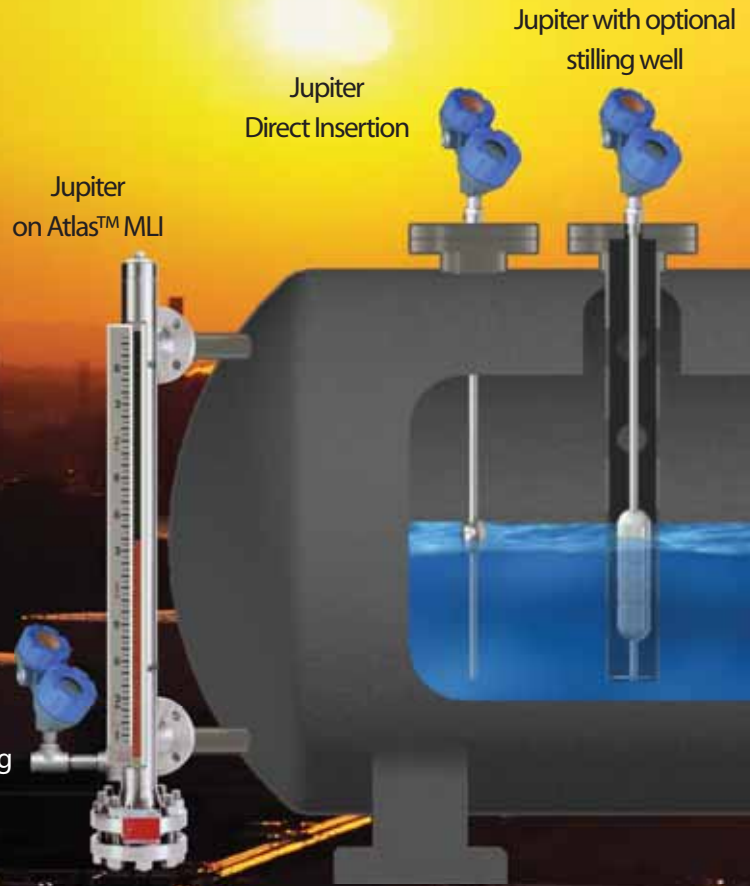

SAFETY INTEGRITY LEVELS 1 & 2

SIL is a device's Safety Integrity Level per IEC 61511. Because combined sensors can increase the SIL, it is often stated as "1 as 1oo1 / 2 as 1oo2," meaning: SIL 1 if the device is one-out-of-one used; SIL 2 if it is one-out-of-two devices used. A device suitable for SIL 2 as 1oo1 means a single device satisfies the SIL 2 requirement.

Orion's Enhanced Jupiter is the first magnetostrictive transmitter to achieve SIL 2 as 1oo1 designation.

Refer to Magnetrol Bulletin 41-299 for more detailed information.



SIL Brochure 41-299

	Model 20X/22X/24X		Model 26X	
SIL	1 as 1oo1		2 as 1oo1	
Instrument Type	B		B	
SFF	83.7%		90.7%	
PFDavg	9.60 ⁻⁰⁴		5.45 ⁻⁰⁴	
	FITS	Annual	FITS	Annual
Fail Dangerous Undetected	218	1.91 ⁻⁰³	123	1.08 ⁻⁰³
Fail Dangerous Detected	698	6.11 ⁻⁰³	793	6.95 ⁻⁰³
Safe	421	3.69 ⁻⁰³	413	3.62 ⁻⁰³

Jupiter with dual level detection

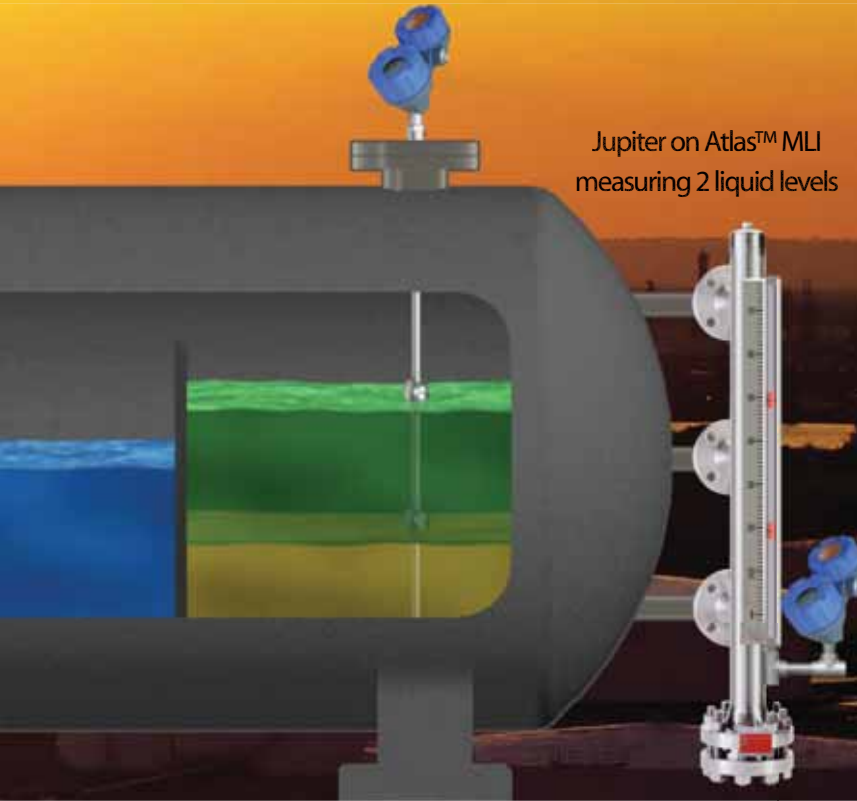

Jupiter on Atlas™ MLI measuring 2 liquid levels

MULTI-VARIABLE LEVEL TRACKING

Many applications that exist in today's process industries involve more than one liquid in a vessel. Jupiter level transmitters can simultaneously track **total level** (upper liquid layer), as well as **interface level** (lower liquid layer).

For HART® transmitters, the user can choose which level variable is exported via the 4 - 20 mA loop. If a second output is required, simply tie in a HART® Interface Module (HIM).

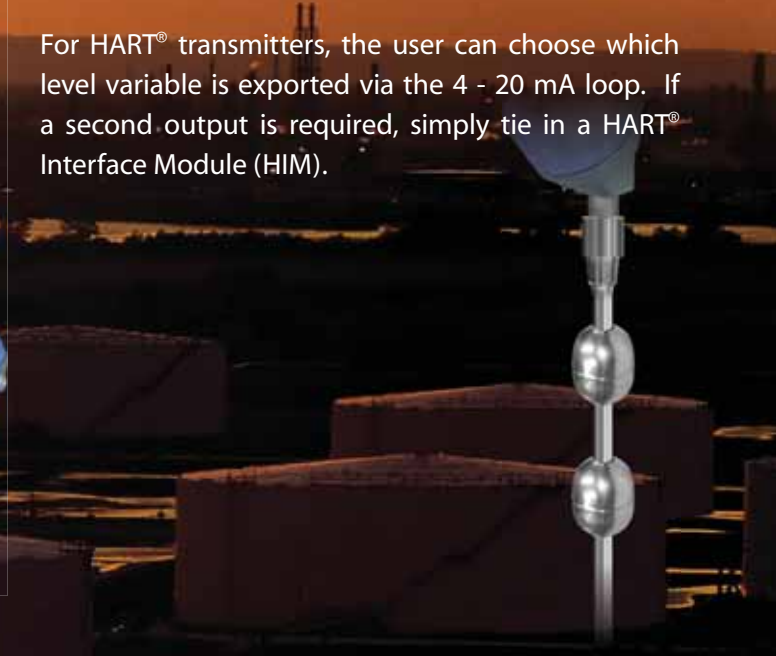

PACTware™ COMMUNICATION TOOL

PACTware™ PC software and the field Device Tool (FDT) standard take magnetostrictive level measurement to a new degree of setup efficiency and user friendliness. The powerful Enhanced Jupiter magnetostrictive transmitter has always been easy to use. PACTware™ builds on that ease of use by adding a graphical software interface. Simply connect a serial or USB-style HART® interface to your PC to remotely access all of the transmitter's functions, as well as signal waveforms, trends, parameters, and more.

Refer to PACTware™ bulletins 59-101 and 59-601 for more information.



FLOAT-BASED PERFORMANCE

Jupiter Magnetostrictive technology offers a number of advantages over competing level technologies.

Foam & Turbulence

Magnetostrictive technology relies on the position of a float rather than trying to force energy through the process media.

The presence of **foam** can restrict certain level technologies from recognizing the liquid surface. The Jupiter float simply sinks through most foam layers and floats on the liquid surface, thereby providing an accurate level reading.

Turbulent liquid surfaces can also be problematic for other level technologies. The Jupiter float will continuously remain in contact with the probe at all times, emitting a strong magnetic field focused directly at the magnetostrictive wire.

Dielectric vs. Density

The Jupiter float is weighted specifically for the media density that is being measured. Unlike radar, media dielectric will not affect the performance of Jupiter.

Liquids that experience fluctuations in density will result in minor offsets in level representation. Orion can provide *Float Projection Graphs* which reveal the expected offset for known density fluctuations.

Interface & Emulsions

Interface applications have been described by many as being some of the most challenging around the world. The majority of different level technologies often struggle to clearly differentiate between the two liquid layers due to the presence of large emulsions or rag layers.

By understanding the physical law of buoyancy, Orion designs all interface floats to simply sink through the upper liquid and float on the lower liquid. Even when large emulsions are present, the float will remain in between both liquid layers.

External Chamber / Bridle

- External chambers are available in several configurations and in a variety of materials
- Custom design requirements are our specialty
- Combine an external Jupiter with an Orion magnetic level indicator for expanded control

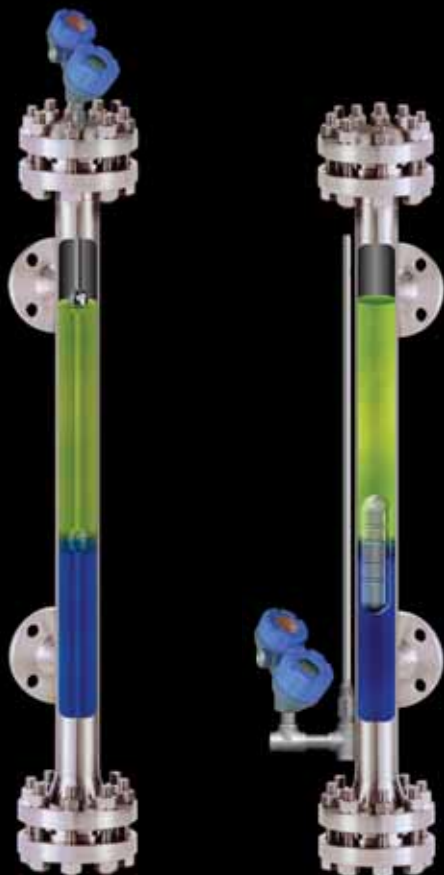

External Chamber / Bridle

Atlas™ with External Jupiter
(visual indicator not shown)

External Chambers & Interface Level

- Multiple process connections are recommended for interface applications to ensure that liquid trapping does not occur (see chamber below)

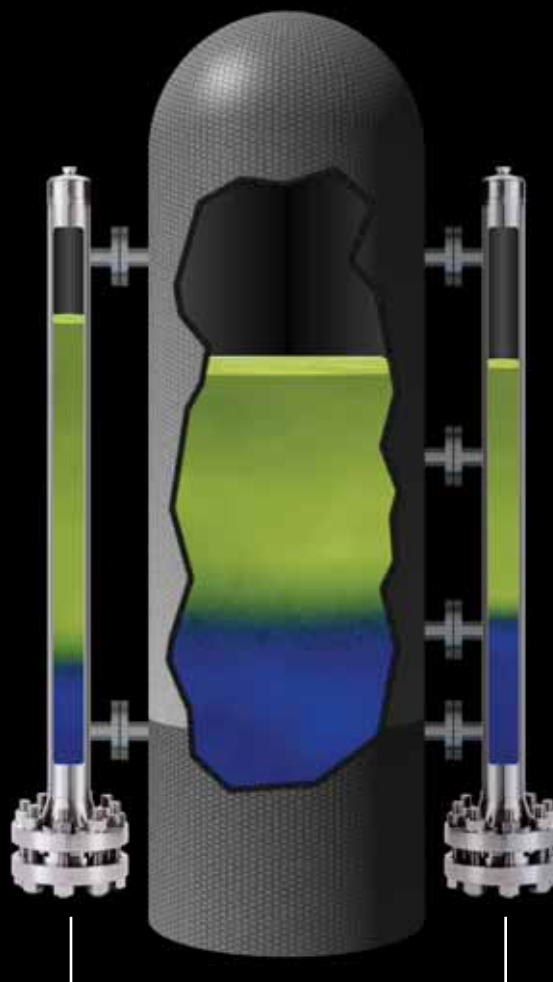

Trapped liquid due to insufficient process connections

Accurate level representation in chamber

Jupiter™ Accessories

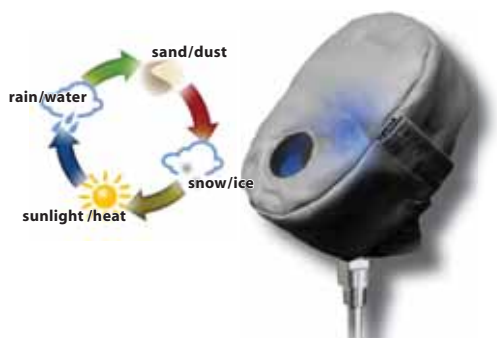

Removable Transmitter Head Cover | insulates and further protects transmitter head from nature's most unforgiving elements

Centering Disc | provided with direct insertion probes that are to be installed in chambers or stilling wells

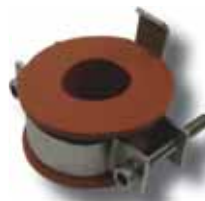

Vibration Isolator Kit | dampens vibration at the probe to improve quality and stability of the signal

PERFORMANCE

Accuracy	±0.015 in
Repeatability	±0.005% of full span or 0.005 in (0.127 mm) (whichever is greater)
Linearity	0.020% of full span or 0.031 in (0.794 mm) (whichever is greater)
Maximum level rate of change	6 in/second (models with HART®)
Response time	0.1 second
Warm-up time	<5 seconds
Upper dead zone	None
Lower dead zone	<3 in (7.6 cm), SIL 2: 5 in (12.7 cm) ①
Ambient temperature range Transmitter:	FM/CSA: -40 to +175° F (-40 to +80° C) ATEX/IEC/INMETRO: -40 to +160° F (-40 to +70° C)
LCD:	-10 to +160° F (-20 to +70° C)
Process temperature External Mount:	-320 to +248° F (-40 to +120° C) -320 to +850° F (-195 to +455° C) (with factory insulated MLI)
Direct Insertion:	-320 to +200° F (-195 to +95° C) -40 to +500° F (-40 to +260° C) (high temperature probe)
Humidity	0 to 99% non-condensing
Electromagnetic compliance	EN 61326
Environmental protection compliance	EN 60654-1
Drop protection compliance	EN 50178
Surge Protection Compliance	EN 61326 (1000 V)
Maximum Pressure (Direct Insertion)	1700 psig @ +100° F (117 bar @ +38° C) (limited to the pressure rating of the selected float)

① 5" inactive zone applies to direct insertion transmitters requiring SIL 2 compliance.

FUNCTIONAL





Measured variables	Continuous liquid level
Input power (at terminals)	12-28 VDC
Signal output ②	4-20 mA 4-20 mA with HART® 5.0 NAMUR NE 43 compliant with 3.8 to 21.5 mA useable range
Loop resistance	620 maximum ohms @ 24 VDC—refer to chart below
Power consumption	0.7 watt, refer to chart below
Damping	0 to 25 seconds
Error signal	3.6 or 22 mA, field selectable
User interface	3-button keypad, HART® communicator, AMS software, PACTware™ or FOUNDATION fieldbus™
Display	2-line × 8-character LCD in inches or cm, mA, and % of level
Resolution	Analog: 0.01 mA Digital: 0.01 units
Span	3 to 397 in (8 to 992 cm)
SIL 2	Safe Failure Fraction (SFF) 90.7% (consult factory for SIL safety manual)

② See Bulletin 46-649 for FOUNDATION fieldbus™ output

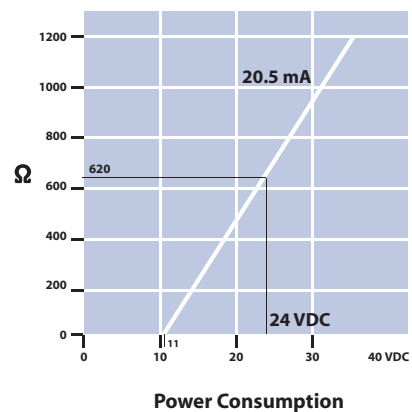
PHYSICAL

Enclosure type	Dual compartment
Enclosure material	Sand cast aluminum grade 356 HT or 316 stainless steel
Enclosure finish	Baked on polymer powder coat
Enclosure rating	NEMA 4X7/9, IP 66
Probe material	316 SS, Hastelloy® C276, Monel®
Sensor length	6 to 400 inches (15 to 999 centimeters)



Agency	Model	Protection Method	Area Classification
FM & CSA  	2xx-1xxx-xxxxx-xxx	Intrinsically Safe	Class I, Div. 1, Groups A, B, C, & D, T4 Ta @ 80°C Class II, Div. 1, Groups E, F, & G; Class III, T4 Ta @ 80°C IP66 TYPE 4X Entity
	2xx-3xxx-xxxxx-xxx	Explosion Proof ①③	Class I, Div. 1, Groups B, C, & D, T5 Ta @ 80°C Class II, Div. 1, Groups E, F, & G; Class III, T5 Ta @ 80°C IP66 Type 4X
	2xx-1xxx-xxxxx-xxx 2xx-2xxx-xxxxx-xxx	Non-Incendive ④	Class I, Div. 2, Groups A, B, C, & D, T5 Ta @ 80°C Class II, Div. 2, Groups E, F, & G②; Class III, T5 Ta @ 80°C IP66 Type 4X T5
ATEX 	2xx-Axxx-xxxxx-xxx	Flame Proof	Ⓔ II 1/2 G EEx d IIC T6 @ 70°C
	2xx-Bxxx-xxxxx-xxx	Intrinsically Safe	Ⓔ II 1 G EEx ia IIC T4 @ 70°C FISCO
IEC 	2xx-Cxxx-xxxxx-xxx	Flame Proof	Ex d IIC T6 @ 70°C
	2xx-Dxxx-xxxxx-xxx	Intrinsically Safe ⑤	Ex ia IIC T4 @ 70°C Ga FISCO
INMETRO 	2xx-Fxxx-xxxxx-xxx	Flame Proof	Br- Ex d IIC T6 @ 70°C, IP66W
	2xx-Gxxx-xxxxx-xxx	Intrinsically Safe ⑤	Br-Ex ia IIC T4 @ 70°C, IP66W FISCO



These units are in conformity of:
 1. The EMC Directive: 2004/108/EC. The units have been tested to EN 61326.
 2. Directive 94/9/EC for equipment or protective system for use in potentially explosive atmospheres.

- ① M20 conduit connections not CSA approved explosion proof
- ② FM approval class II, Div. 2 Groups F & G only
- ③ Factory Sealed: This product has been approved by Factory Mutual Research (FM), and Canadian Standards Association (CSA), as a Factory Sealed device.
- ④ **IMPORTANT:** Measured media inside vessel must be non-flammable only. If media inside vessel is flammable, then the explosion proof version (which contains an internal barrier making the probe Intrinsically Safe) is required.
- ⑤ **Special conditions for safe use**
 Materials marked as category 1 equipment and used in hazardous areas requiring this category, shall be installed in such a way that, even in the event of rare incidents, the aluminum enclosure cannot be an ignition source due to impact or friction.

ADDITIONAL CERTIFICATIONS (consult factory)

GOST R Russian Certificate of Conformity
GOST Pattern Approval Certificate for Measuring Instruments (Metrology Certificate)
GOST R Ex-Proof Certificate of Conformity

Digits 1 through 10 (See next page for digits 11 through 15)

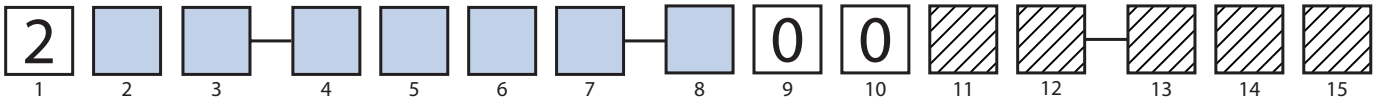

1 | PRODUCT SELECTION

2	Jupiter Magnetostrictive Level Transmitter
---	--

2 | OUTPUT

4	HART®, 4-20 mA, LCD Display, SIL 1
5	FOUNDATION fieldbus™, LCD Display
6	HART®, 4-20 mA, LCD Display, SIL 2
7	Two level tracking, HART utilizing two MLI floats
8	Two level tracking, FOUNDATION fieldbus™ utilizing two MLI floats

3 | HOUSING AND CONDUIT ENTRY

1	Cast Aluminum, Integral Mount with 3/4" NPT Conduit Entry
2	Cast Aluminum, Integral Mount with M20 Conduit Entry
3	316 SS, Integral Mount with 3/4" NPT Conduit Entry
4	316 SS, Integral Mount with M20 Conduit Entry

4 | AREA CLASSIFICATION

1	FM/CSA, Intrinsically Safe, Non-Incendive
3	FM/CSA, Explosion Proof, Non-Incendive
A	ATEX, Ex d IIC T6, Flameproof
E	ATEX, Ex ia IIC T4, Intrinsically Safe
J	IEC, Ex d IIC T6, Flameproof
K	IEC, Ex ia IIC T4, Intrinsically Safe
L	INMETRO, Ex d IIC T6, Flameproof
M	INMETRO, Ex ia IIC T4, Intrinsically Safe

5 | CONFIGURATION

E	Top Mount, Material Code 1 only
F	Top Mount Offset, Material Code 1 only
G	Top Mount Offset, High Temperature, Material Code A only
H	Bottom Mount Offset, Material Code 1 only
J	Bottom Mount Offset, High Temperature, Material Code A only

6-7 | MOUNTING LOCATION

00	External Mount on MLI or Chamber, Left Side (standard)
01	External Mount on MLI or Chamber, Right Side

8 | PROBE MATERIAL OF CONSTRUCTION

1	316/316L SS (standard), +250° F (+120° C) Maximum
A	316/316L SS (high temp), +500° F (+260° C) Maximum +850° F (+454° C) with factory-installed fiberglass insulation

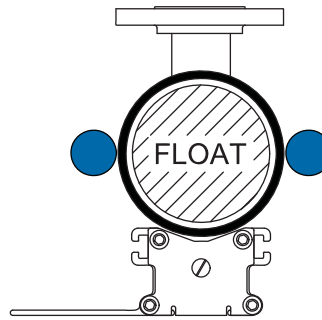

Probe mounting positions on Atlas™, Stratus™, and Gemini™ MLI

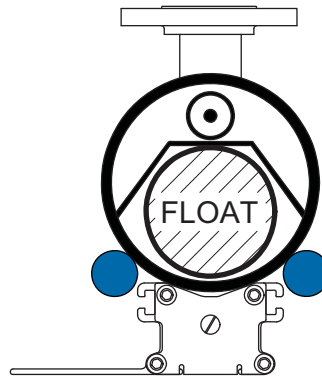

Probe mounting positions on Aurora® MLI

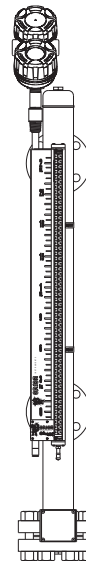

Left side mount (standard)

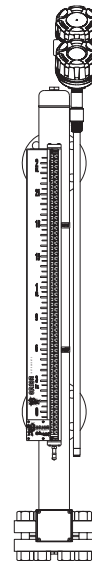

Right side mount

Note: When specifying the mounting location, be aware of other accessories that may also mount on the MLI (i.e. switches, heat tracing, etc). Choose left side mount whenever possible.

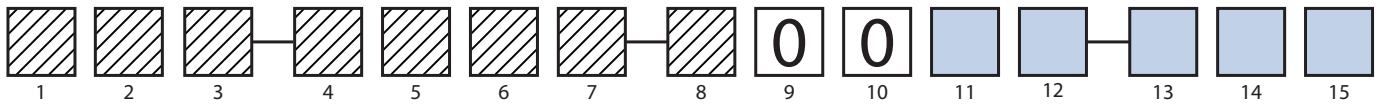

11 | CHAMBER MOUNTING CODE

Without High-Temp Chamber Insulation		With High-Temp Chamber Insulation	
1	MLI model code digit 20 is 1, 2, or 7	E	MLI model code digit 20 is 1, 2, or 7
2	MLI model code digit 20 is 3, 4, 5 or 6	F	MLI model code digit 20 is 3, 4, 5 or 6
3	MLI model code digit 20 is A, B, C, or D	G	MLI model code digit 20 is A, B, C, or D
4	MLI model code digit 20 is E, F, G, H, or J	H	MLI model code digit 20 is E, F, G, H, or J
5	MLI is a Top Mount design	J	MLI is a Top Mount design
0	None (if clamps already exist)	0	None (if clamps already exist)

12 | UNIT OF MEASURE

E	Probe length in English units (inches)
M	Probe length in Metric units (centimeters)

13-15 | PROBE LENGTH

XXX	Specify required probe length. See figures to the right.
-----	--

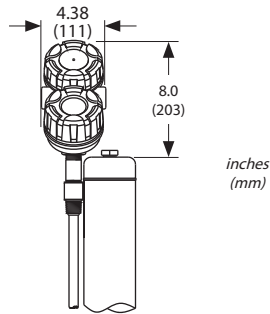

Top Mount

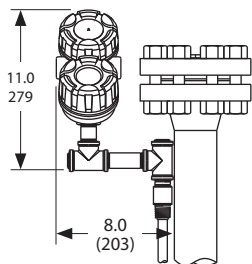

Top Mount Offset

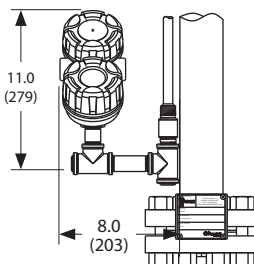

Bottom Mount Offset

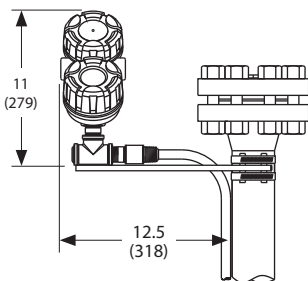

Top Mount Offset High Temperature

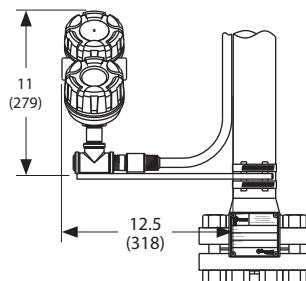

Bottom Mount Offset High Temperature

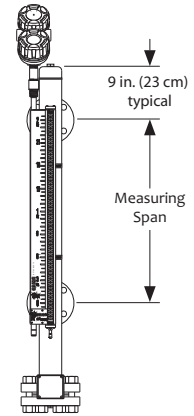

Top Mount Configuration

Probe Length = Center-to-Center + 8 in. (20 cm)

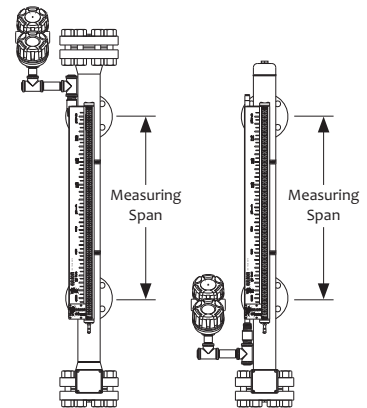

Top/Bottom Mount Offset Configuration

Probe Length = Center-to-Center + 6 in. (15 cm)

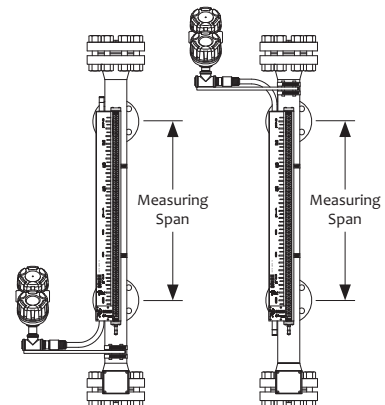

Hi-Temp Top/Bottom Mount Offset Configuration

Probe Length = Center-to-Center + 15 in. (38 cm)

Digits 1 through 8 (See next page for digits 9 through 15)

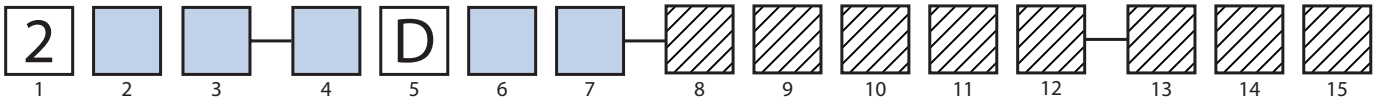

1 | PRODUCT SELECTION

2	Jupiter Magnetostrictive Level Transmitter
---	--

2 | OUTPUT

4	HART®, 4-20 mA, LCD Display, SIL 1
5	FOUNDATION fieldbus™, LCD Display
6	HART®, 4-20 mA, LCD Display, SIL 2 ①
7	Dual-level, HART® utilizing two floats
8	Dual-level, FOUNDATION fieldbus™ utilizing two floats

3 | HOUSING AND CONDUIT ENTRY

1	Cast Aluminum, Intergral Mount with 3/4" NPT Conduit Entry
2	Cast Aluminum, Intergral Mount with M20 Conduit Entry
3	316 SS, Intergral Mount with 3/4" NPT Conduit Entry
4	316 SS, Intergral Mount with M20 Conduit Entry

4 | AREA CLASSIFICATION

1	FM/CSA, Intrinsically Safe, Non-Incendive
3	FM/CSA, Explosion Proof, Non-Incendive
A	ATEX, Ex d IIC T6, Flameproof
E	ATEX, Ex ia IIC T4, Intrinsically Safe
J	IEC, Ex d IIC T6, Flameproof
K	IEC, Ex ia IIC T4, Intrinsically Safe
L	INMETRO, Ex d IIC T6, Flameproof
M	INMETRO, Ex ia IIC T4, Intrinsically Safe

5 | CONFIGURATION

D	Direct Insertion
---	------------------

① The bottom 5 in (12.7 cm) of a SIL 2 the probe is inactive. The inactive zone is required to detect float failure (larger inactive zones may be required if non-standard floats are specified. Consult factory for more information).

6-7 | MOUNTING CONNECTION

Threaded Options

11	3/4" NPT thread
41	2" NPT thread
22	1" BSP thread

Flange Options (Industrial)

23	1" 150# RF ANSI Flange
24	1" 300# RF ANSI Flange
25	1" 600# RF ANSI Flange
27	1" 900/1500# RF ANSI Flange
33	1 1/2" 150# RF ANSI Flange
34	1 1/2" 300# RF ANSI Flange
35	1 1/2" 600# RF ANSI Flange
37	1 1/2" 900/1500# RF ANSI Flange
43	2" 150# RF ANSI Flange
44	2" 300# RF ANSI Flange
45	2" 600# RF ANSI Flange
47	2" 900/1500# RF ANSI Flange
53	3" 150# RF ANSI Flange
54	3" 300# RF ANSI Flange
55	3" 600# RF ANSI Flange
56	3" 900# RF ANSI Flange
63	4" 150# RF ANSI Flange
64	4" 300# RF ANSI Flange
65	4" 600# RF ANSI Flange
66	4" 900# RF ANSI Flange
EA	DN80 PN16 EN 1092-1 Type A
EB	DN80 PN25/40 EN 1092-1 Type A
FA	DN100 PN16 EN 1092-1 Type A
FB	DN100 PN25/40 EN 1092-1 Type A

Flange Options (Hygienic)

3P	1" - 1 1/2" Tri-Clamp®
4P	2" Tri-Clamp®
5P	3" Tri-Clamp®
6P	4" Tri-Clamp®

Sizing Chart for Chambers & Stilling Wells

Reference the chart below to identify an appropriate chamber or stilling well size for your application. Adequate clearance is recommended to ensure proper float operation.

Float Diameter inches (mm)	Probe Lengths ≤ 144 inches (366 cm)						Probe Lengths > 144 in (366 cm)	
	3" sch. 5/10	3" sch. 40	4" sch. 5/10	4" sch. 40	4" sch. 80	4" sch. 160	4" sch. 10	4" sch. 40
1.85 (47)	•	•	•	•	•	•	•	•
2 (51)	•		•	•	•	•	•	•
2.3 (58)			•	•	•			
2.5 (64)			•	•				
3 (76)								

Transmitter Head Dimensions

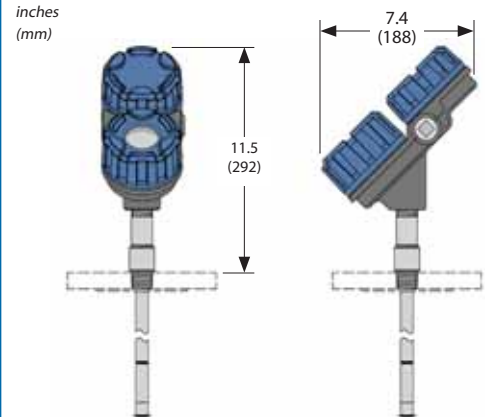

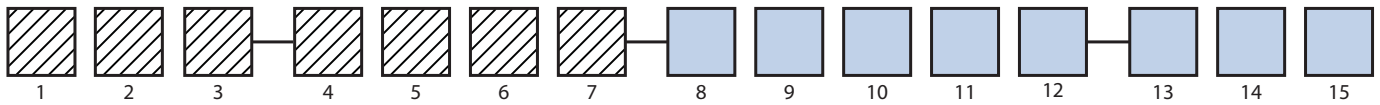

8 | MATERIAL OF CONSTRUCTION

Max Process Temperature: +200°F (96°C)

1	316/316L SS (standard)
2	Hastelloy® C276
3	Monel®

Max Process Temperature: +500°F (260°C)

A	316/316L SS (standard)
B	Hastelloy® C276
C	Monel®
D	Hygienic 316/316L SS, SF1: 20 µin (0.51 µm) Mechanically Polished
E	Hygienic 316/316L SS, SF4: 15 µin (0.38 µm) Electropolished

9-10 | DIRECT INSERTION FLOAT(S)

See Page 14 for standard floats.
Consult factory regarding floats not listed for your application(s).

11 | INSTALLATION CONSIDERATIONS

A	Transmitter to be mounted in vessel without stilling well
B	Transmitter to be mounted in chamber, bridle, or stilling well

12 | UNIT OF MEASURE

E	Insertion length in English units (inches)
M	Insertion length in Metric units (centimeters)

13-15 | INSERTION LENGTH

XXX	Specify required insertion length. See figures to the right. Example: 87 inches = 087 Code 12 must be "E" Example: 120 centimeters = 120 Code 12 must be "M"
-----	--

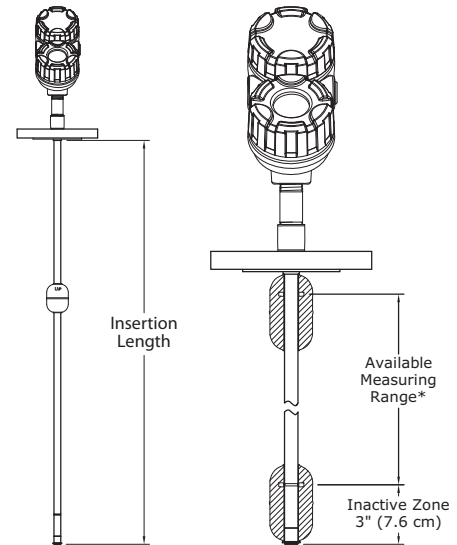

* Available measuring range and inactive zone may vary depending on float dimensions and magnet placement. Reference standard float dimensions on page 14.

Standard Direct Insertion Models

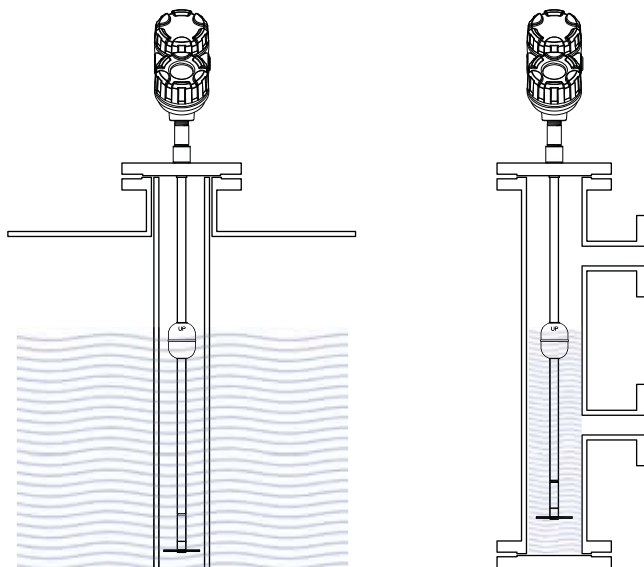

Units mounted in stilling wells or chambers are provided with centering discs at the base of the probe

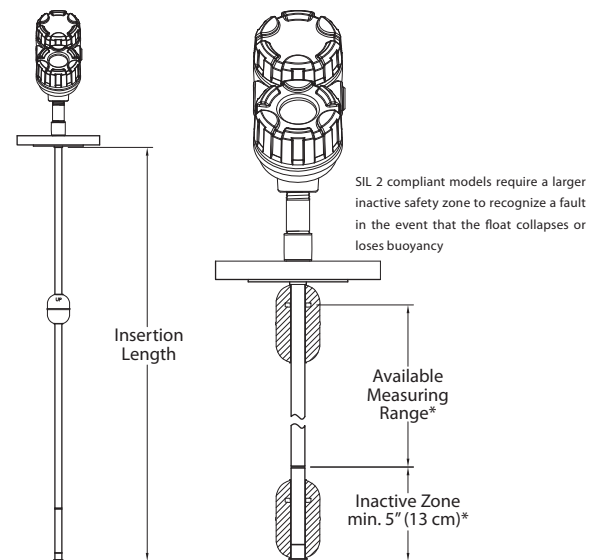

* Available measuring range and inactive zone may vary depending on float dimensions and magnet placement. Reference standard float dimensions on page 14.

SIL 2 Direct Insertion Models

The floats listed below are suitable for most applications. Select the appropriate 2-digit float code and place it in the Jupiter model number (locations 9 & 10). Consult factory for custom floats or to consult about your specific application.

Direct Insertion Total Level Float (uppermost liquid layer)

Minimum Liquid Specific Gravity	316/316L SS	Titanium	Hastelloy® C	Hygienic Service 316/316L SS SF1: 20 µin (0.51 µm)	Hygienic Service 316/316L SS SF4: 15 µin (0.38 µm)
≥ 0.86	AA 2.0" (51 mm) dia.	BA 2.0" (51 mm) dia.	CA 1.85" (47 mm) dia.	DA 2.0" (51 mm) dia.	FA 2.0" (51 mm) dia.
≥ 0.83	AA 2.0" (51 mm) dia.	BA 2.0" (51 mm) dia.	CB 2.25" (57 mm) dia.	DA 2.0" (51 mm) dia.	FA 2.0" (51 mm) dia.
≥ 0.7	AB 2.3" (58 mm) dia.	BA 2.0" (51 mm) dia.	CB 2.25" (57 mm) dia.	DB 2.3" (58 mm) dia.	FB 2.3" (58 mm) dia.
≥ 0.68	AB 2.3" (58 mm) dia.	BB 2.25" (57 mm) dia.	99 consult factory	DB 2.3" (58 mm) dia.	FB 2.3" (58 mm) dia.
≥ 0.64	AC 2.5" (64 mm) dia.	BB 2.25" (57 mm) dia.	99 consult factory	DC 2.5" (64 mm) dia.	FC 2.5" (64 mm) dia.
≥ 0.52	99 consult factory dia.	BB 2.25"(57 mm) dia.	99 consult factory	99 consult factory dia.	99 consult factory dia.
< 0.52	99 consult factory	99 consult factory	99 consult factory	99 consult factory	99 consult factory

Direct Insertion Interface Level Float (lower or middle liquid layer)

Minimum Liquid Specific Gravities upper / lower	316/316L SS	Titanium	Hastelloy® C	Hygienic Service 316/316L SS SF1: 20 µin (0.51 µin)	Hygienic Service 316/316L SS SF4: 15 µin (0.38 µin)
sinks thru / floats on ≤ 0.89 / ≥ 1.00	MA 2.0" (51 mm) dia.	NA 2.0" (51 mm) dia.	PA 1.85" (47 mm) dia.	QA 2.0" (51 mm) dia.	RA 2.0" (51 mm) dia.
sinks thru / floats on ≤ 1.00 / ≥ 1.12	MB 2.0" (51 mm) dia.	NB 2.0" (51 mm) dia.	PB 1.85" (47 mm) dia.	QB 2.0" (51 mm) dia.	RB 2.0" (51 mm) dia.

PRESSURE / TEMPERATURE RATINGS FOR STANDARD FLOATS

Temp °F (°C)	Pressure Rating (includes 1.5x safety factor) psig (bar)				
	AA, AB, AC, MA, MB DA, DB, DC, QA, QB FA, FB, FC, RA, RB	BA, NA, NB	BB	CA, PA, PB	CB
70 (21)	440 (30.3)	750 (51.7)	400 (27.6)	340 (23.4)	320 (22.1)
100 (38)	403 (27.8)	719 (49.6)	383 (26.4)	329 (22.7)	310 (21.4)
200 (93)	381 (26.3)	656 (45.2)	350 (24.1)	318 (22)	299 (20.6)
250 (121)	367 (25.3)	578 (39.9)	308 (21.2)	310 (21.4)	292 (20.1)
300 (149)	352 (24.3)	500 (34.5)	267 (18.4)	303 (20.9)	285 (19.7)
350 (177)	337 (23.2)	445 (30.7)	238 (16.4)	292 (20.1)	275 (19)
400 (204)	323 (22.3)	391 (27)	208 (14.3)	281 (19.4)	264 (18.2)
450 (232)	315 (21.7)	352 (24.3)	188 (13)	273 (18.8)	257 (17.7)
500 (260)	308 (21.2)	313 (21.6)	167 (11.5)	266 (18.3)	250 (17.2)

PHYSICAL DIMENSIONS

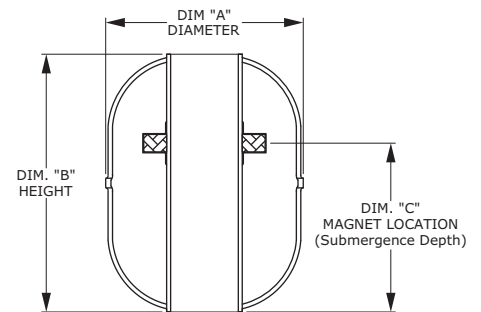

Float Code	Dim. A in. (mm)	Dim. B in. (mm)	Dim. C in. (mm)
AA,DA,FA	2.0 (51)	2.7 (69)	1.84 (47)
AB,DB,FB	2.3 (58)	3.0 (76)	2.0 (51)
AC,DC,FC	2.5 (64)	3.0 (76)	2.14 (54)
BA	2.0 (51)	2.8 (71)	1.98 (50)
BB	2.25 (57)	3.0 (76)	2.08 (53)
CA	1.85 (47)	3.0 (76)	2.06 (52)
CB	2.25 (57)	4.3 (109)	3.01 (76)
MA,QA,RA	2.0 (51)	2.7 (69)	1.35 (34)
MB,QB,RB	2.0 (51)	2.7 (69)	1.35 (34)
NA	2.0 (51)	2.8 (71)	1.4 (36)
NB	2.0 (51)	2.8 (71)	1.4 (36)
PA	1.85 (47)	3.0 (76)	1.5 (38)
PB	1.85 (47)	3.0 (76)	1.5 (38)

Two Floats for Total Level and Interface Measurement

Code	Total	Interface	Code	Total	Interface
11	AA	MA	32	BB	NA
12	AB		41	BA	NB
13	AC		42	BB	
21	AA	MB	51	CA	PA
22	AB		52	CB	PB
23	AC		61	CA	
31	BA	NA	62	CB	

When utilizing two floats to measure total and interface liquid levels, reference the chart on the left to determine the appropriate float code to insert into the Jupiter model number.

Customer Name _____
 Quote Reference # _____
 Email Address _____

Jupiter Model Number

2 - - -

Process Media _____
 Media Specific Gravity _____
 Maximum Operating Pressure _____
 Maximum Operating Temperature _____

Low Level Set Point (4mA / 0%) _____
 High Level Set Point (20mA / 100%) _____

MEASUREMENTS FROM TIP OF SENSOR TUBE.
 IF MOUNTED IN CHAMBER OR BRIDLE, SPECIFY "C/L OF PROCESS CONNECTION"

GENERAL INFORMATION

IS PRE-EXISTING CHAMBER OR STILLING WELL PRESENT? Y / N

- INNER DIAMETER: _____

IS MODERATE VIBRATION PRESENT? Y / N

- PLEASE DESCRIBE: _____

IS TURBULENCE OR FLOW PRESENT? Y / N

- PLEASE DESCRIBE: _____

IMPORTANT INFORMATION REGARDING SIL 2 COMPLIANT MODELS
 IF SIL 2 CONSTRUCTION IS REQUIRED, AN ADDITIONAL 2" (5.1 cm) INACTIVE SECTION MUST BE ADDED TO THE BASE OF THE PROBE IN ORDER FOR THE FLOAT TO TRAVEL OUT OF THE ACTIVE SPAN IN THE EVENT OF A FAILURE.

THE 5" (12.7 cm) DIMENSION IS STANDARD FOR ALL STANDARD FLOATS OFFERED IN THE JUPITER SALES LITERATURE. EXCEPTIONS MAY REQUIRE A LONGER INACTIVE DIMENSION. CONSULT FACTORY.

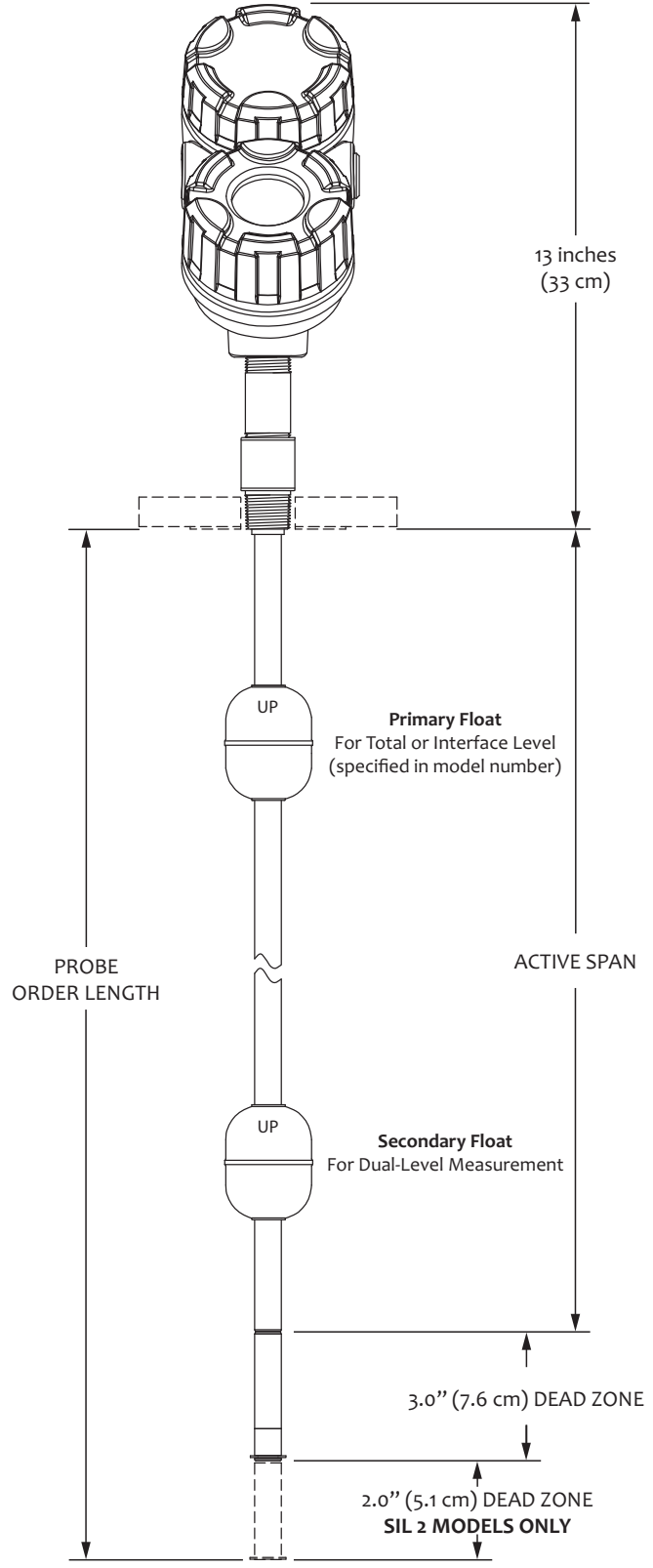

if SIL 2 is not required, disregard the additional 2" (5.1 cm) dead zone when specifying the probe order length



Orion maintains competitive lead times for all of our products. If expedited shipping is required, we can accommodate your request.

To improve delivery on your order, contact your local *Orion Instruments* representative or contact us directly.



ORION[®]

INSTRUMENTS

A Magnetrol Company



2105 Oak Villa Drive • Baton Rouge, Louisiana 70815 • 225-906-2343 • Toll Free 866-55-ORION (866-556-7466) • Fax 225-906-2344 • www.orioninstruments.com

Copyright © 2011 Orion Instruments, LLC. All rights reserved. Printed in the USA.
Performance specifications are effective with date of issue and are subject to change without notice

Orion and Orion logotype, Jupiter, and Aurora are registered trademarks of Magnetrol International
Atlas, Gemini and Stratus are trademarks of Magnetrol International
HART[®] is a registered trademark of the HART Communication Foundation
Hastelloy[®] is a registered trademark of Haynes International
Monel[®] is a registered trademark of Special Metals Corporation
Tri-Clamp[®] is a registered trademark of Ladish Company
Asset Management Solutions (AMS) is a trademark of Emerson Process Management
FOUNDATION fieldbus[™] is a trademark of Fieldbus Foundation
Cover photograph "Oil Refinery at Night" courtesy of Denise J. Mayes

BULLETIN: ORI-148.5
EFFECTIVE: January 2011