

INSTRUCTION MANUAL AND REPLACEMENT PARTS

DESCRIPTION

Magnetrol's B40 liquid level switch is specifically designed and constructed for high pressure, high temperature service conditions. (It is suitable for use on 0.65 minimum specific gravity liquids).

OPERATING PRINCIPLE

B40 level switches employ permanent magnetic force as the only link between the float and the switching element. As the pivoted float follows liquid level changes, it moves a magnetic sleeve ① into or out of the field of a switch actuating magnet ② causing switch operation.

A non-magnetic barrier tube ③ effectively isolates the switch mechanism from the controlled liquid.

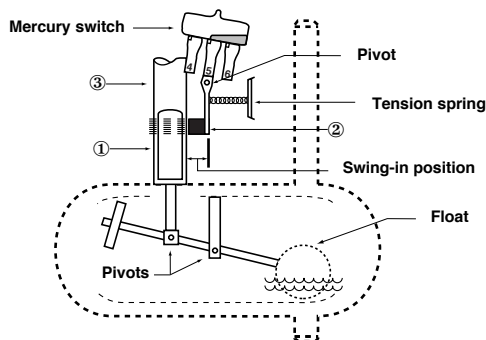

UNPACKING

Unpack the instrument carefully. Inspect all units for damage. Report any concealed damage to carrier within 24 hours. Check the contents of the packing slip and purchase order. Check and record the serial number for future reference when ordering parts.

AGENCY APPROVALS

Agency	Approval
ATEX	II 2G EEx d II C T6, explosion proof
CCE ①	R1 (1) 136/MI/433, explosion proof
FM	Class I, Div. 1, Groups C & D Class II, Div. 1, Groups E, F & G, Type NEMA 7/9
FM/CSA ②	Non-Hazardous area Explosion proof area – Groups B, C, D, E, F & G Type NEMA 4X/7/9
SAA ②	Explosion proof area
LRS	Lloyds Register of Shipment (marine applications)
GOST/ GOSGORTECHNADZOR ②	Russian Authorisation Standards
Other approvals are available, consult factory for more details	

① For CCE approved units, use the ATEX explosion proof model numbers.

② Consult factory for proper model numbers.

MODEL IDENTIFICATION

A complete measuring system consists of:

1. Code for high temperature / high pressure liquid float level switch in an external cage

BASIC MODEL NUMBER

B 4 0	cage mounted float switch for high temperature / high pressure applications	Down to S.G. 0,65
-------	---	-------------------

MATERIALS OF CONSTRUCTION

Code	Cage	Float	Tank connections	Pressure & temperature ratings
R F 3 0	Cr Mo (Chrome-moly)	347 SST (1.4550) or 321 SST (1.4541)	1" welding nipples	115 bar @ 425°C - 59,8 bar @ 540°C max (1668 psi @ 800°F - 867 psi @ 1000°F max)
R B 6 0			1" socket weld	
C F 3 0	304 SST (1.4301)	316 SST (1.4401)	1" welding nipples	85,5 bar @ 425°C max (1240 psi @ 800°F max)
C B 6 0			1" socket weld	
A C 3 0	Carbon steel	347 SST (1.4550) or 321 SST (1.4541)	1 1/2" socket weld	103 bar @ 340°C - 75,9 bar @ 425°C max (1500 psi @ 650°F - 1100 psi @ 800°F max)
D C 4 0	316 SST (1.4401)			207 bar @ 370°C max (3000 psi @ 700°F max) saturated steam

SWITCH MECHANISM & ENCLOSURE

qty and switch type		Weather proof (IP 66)		ATEX (IP 66)		FM (IP 66)
		cast Aluminium		II 2G EEx d II C T6 cast Aluminium		NEMA 7/9 cast Alu.
		M20 x 1,5	1" NPT	M20 x 1,5	1" NPT	1" NPT
F	1 x SPDT	FCB	FAB	FK9	FC9	FKB
	1 x DPDT	FGB	FDB	FN9	FF9	FNB
S for AC current	1 x SPDT	S2B	SAB	SH9	SA9	SKB
	1 x DPDT	S8B	SDB	SJ9	SB9	SNB
S for DC current	1 x SPDT	S2R	SBB	SK9	SC9	SLB
	1 x DPDT	S8R	SEB	SN9	SF9	SOB

qty and switch type		Weather proof (IP 65)		NEMA 7/9 (IP 66)
		Alu base / cold rolled steel cover		cast Iron
		3/4" NPT		1" NPT
L	1 x SPDT	LAM		LKM
	1 x DPDT	LDM		LNK

B 4 0 [] [] [] [] 0 [] [] [] complete code for B40 models

INSTALLATION

PIPING

Figure 3 shows a typical piping installation of a Model B40 in a pipeline to a pressure vessel. Reference lines, on float chamber, should be aligned to correspond with liquid level in the vessel at which switch control is desired (refer to dimensional drawing, if furnished).

Use pipe of sufficient strength to support the unit. If necessary, provide a stand or hanger to help support its weight. All piping should be straight and free of low spots or pockets so that the lower liquid line will drain towards the vessel, and the upper vapor line will drain towards the control. Pipeline should be insulated, as shown, to minimize loss of liquid temperature and further control of the heat in the area of the switch housing. **DO NOT** insulate switch housing or float chamber.

NOTE: Manufacturer recommends that when welding chrome-moly steel piping, the procedures used conform to AWS-D10.8-61.

MOUNTING

Before welding, adjust piping to bring control to a vertical position. B40 level controls must be mounted within three (3°) degrees of vertical. A three degree slant is noticeable by eye, but installation should be checked using a spirit level. Controls used on boiler applications should be mounted as close to the boiler as possible. This will result in a more responsive and accurate level change in the control. Water in a long line will be cooler and more dense than the boiler water, causing lower level indication in the control than actual level in the boiler.

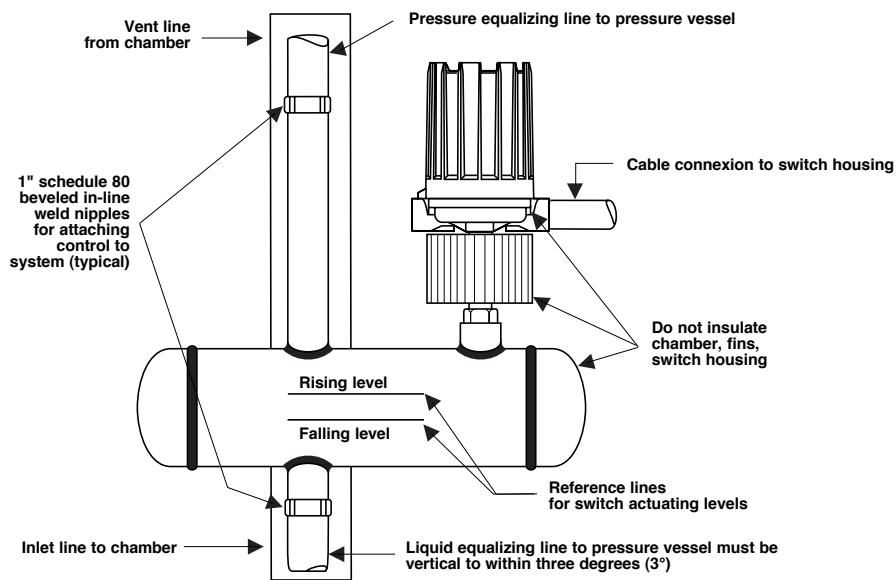

Figure 3

WIRING

Most mechanical control switch housings are designed to allow 360° positioning of the cable entries by loosening the set screw. See **figure 4**. On high temperature applications (above 120° C [250° F]), high temperature wire should be used between control and first junction box located in a cooler area.

1. To gain access to switch mechanism(s) remove switch housing cover.
2. Pull in supply wires (conductors), wrap them around enclosing tube under the baffle plate and connect to proper terminals. Be certain that excess wire does not interfere with "tilt" of switch and that adequate clearance exists for replacement of switch housing cover.

NOTE: See bulletin on switch mechanism furnished with your control (as listed aside) for proper connections.

3. Connect power supply to control and test switch action by varying liquid level in tank or vessel.

NOTE: If switch mechanism fails to function properly, check vertical alignment of control housing and consult installation instructions in switch mechanism bulletin.

4. Replace switch housing cover and place control into service.

NOTE: If control has been furnished with an explosion proof (cast) or moisture proof (gasketed) switch housing, check the following:

- After wiring connections have been completed, housings must be sealed via the correct cable gland to prevent entrance of air.
- Check cover to base fit, to be certain gasketed joint is tight. A positive seal is necessary to prevent infiltration of moisture laden air or corrosive gases into switch housing.

CAUTION:
In hazardous area, do not power the unit until the cable gland is sealed and the enclosure cover is screwed down securely.

Switch Series Letter	Description	Bulletin N°
L	Mercury Switch w/Beaded Leads	42-783
S	Dry Contact Switch DC current	
L	Vibration Resistant Mercury Switch	
F	Hermetically Sealed Snap Switch	

OBSERVE ALL APPLICABLE ELECTRICAL CODES AND PROPER WIRING PROCEDURES

NEMA 4x/7/9

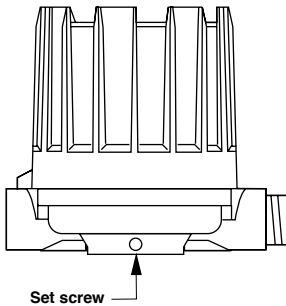

NEMA 7/9

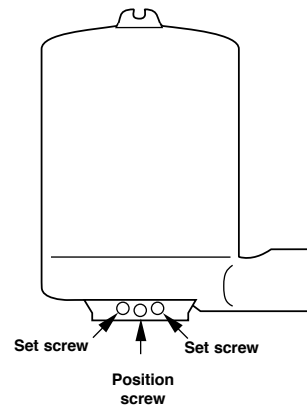

CAUTION:
- DO NOT attempt to reposition NEMA 4x / 7/9 housings without loosening the set screws.

PREVENTIVE MAINTENANCE

Periodic inspections are a necessary means to keep your Magnetrol level control in good working order. This control is, in reality, a safety device to protect the valuable equipment it serves. Therefore, a systematic program of "preventive maintenance" should be implemented when control is placed into service. If the following sections on "what to do" and "what to avoid" are observed, your control will provide reliable protection of your capital equipment for many years.

WHAT TO DO

1. Keep control clean

NEVER leave switch housing cover off the control. This cover is designed to keep dust and dirt from interfering with switch mechanism operation. In addition, it protects against damaging moisture and acts as a safety feature by keeping bare wires and terminals from being exposed. Should the housing cover become damaged or misplaced, order a replacement immediately.

2. Inspect switch mechanisms, terminals and connections monthly.

- Mercury switches may be visually inspected for short circuit damage. Check for small cracks in the glass tube containing the mercury. Such cracks can allow entrance of air into the tube causing the mercury to "oxidize". This is noticeable as the mercury will appear dirty and have a tendency to "string out" like water, instead of breaking into round pools. If these conditions exist, replace the mercury switch immediately.
- Dry contact switches should be inspected for excessive wear on actuating lever or misalignment of adjusting screw at point of contact between screw and lever. Such wear can cause false switch actuating levels. Adjust switch mechanism to compensate (if possible) or replace switch.

Do **NOT** operate your control with defective or maladjusted switch mechanisms (refer to bulletin on switch mechanism furnished for service instructions).

- Magnetrol controls may sometimes be exposed to excessive heat or moisture. Under such conditions, insulation on electrical wires may become brittle, eventually breaking or peeling away. The resulting "bare" wires can cause short circuits.

Check wiring carefully and replace at first sign of brittle insulation.

- Vibration may sometimes cause terminal screws to work loose. Check all terminal connections to be certain that screws are tight. Air (or gas) operating medium lines subjected to vibration may eventually crack or become loose at connections causing leakage. Check lines and connections carefully and repair or replace, if necessary.

NOTE: As a matter of good practice, spare switches should be kept on hand at all times.

3. Inspect entire unit periodically

Isolate control from vessel. Raise and lower liquid level to check for switch contact and reset.

WHAT TO AVOID

1. **NEVER** leave switch housing cover off the control longer than necessary to make routine inspections.
2. **NEVER** use lubricants on pivots of switch mechanisms. A sufficient amount of lubricant has been applied at the factory to insure a lifetime of service. Further oiling is unnecessary and will only tend to attract dust and dirt which can interfere with mechanism operation.
3. **NEVER** place a jumper wire across terminals to "cut-out" the control. If a "jumper" is necessary for test purposes, be certain it is removed before placing control into service.
4. **NEVER** attempt to make adjustments or replace switches without reading instructions carefully. Certain adjustments provided for in Magnetrol controls should not be attempted in the field. When in doubt, consult the factory or your local Magnetrol representative.

TROUBLESHOOTING

Usually the first indication of improper operation is failure of the controlled equipment to function, i.e., pump will not start (or stop), signal lamps fail to light, etc. When these symptoms occur, whether at time of installation or during routine service thereafter, check the following potential external causes first:

- Fuses may be blown.
- Reset button(s) may need resetting.
- Power switch may be open.
- Controlled equipment may be faulty.
- Wiring leading to control may be defective.

If a thorough inspection of these possible conditions fails to locate the trouble, proceed next to a check of the control's switch mechanism.

CHECK SWITCH MECHANISM

1. Pull disconnect switch or otherwise disconnect power to the control.
2. Remove switch housing cover.

3. Disconnect power wiring from switch assembly.
4. Swing magnet assembly in and out by hand to check carefully for any sign of binding. Assembly should require minimal force to move it through its full swing.
5. If binding exists, magnet may be rubbing enclosing tube. If magnet is rubbing, loosen magnet clamp screw and shift magnet position. Retighten magnet clamp screw.
6. If switch magnet assembly swings freely and mechanism still fails to actuate, check installation of control to be certain it is within the specified three (3°) degrees of vertical. (Use spirit level on side of enclosing tube in two places, 90° apart.)
7. If mechanism is equipped with a mercury switch, examine glass mercury tube closely as previously described in "Preventive Maintenance" section. If switch is damaged, replace it immediately.
8. If switch mechanism is operating satisfactorily, consult factory.

REPLACEMENT PARTS

Item	Description	Model Part Number Code						
		B40-1F30	B40-1B60	B40-2F30	B40-2B60	B40-5C20	B40-3C30	B40-4C40
1	Housing Cover	Refer to Bulletin 42-783 or 42-794						
2	Switch Mechanism							
3	Jam Nuts(s)	10-2107-001 (Qty. 4)						
4	Attraction Sleeve	32-4203-001		32-4902-001		32-4203-001		04-5411-002
5	E-Tube Gasket	89-5920-001 E-Tube Kit (w/NEMA 4 Base)			89-5955-001	89-5920-001	89-5951-001	
6	Enclosing Tube				E-Tube Kit (w/NEMA 4 Base)	E-Tube Kit (w/NEMA 4 Base)	E-Tube Kit (w/NEMA 4 Base)	
7	Stud (or Screw)							
8	Lock Nut & Washer							
9	Base Insulating Washer				89-5945-001	89-5955-002	89-5945-001	89-5952-001
10	Base Insulating Liner				E-Tube Kit (w/NEMA 7/9 Base)	E-Tube Kit (w/NEMA 7/9 Base)	E-Tube Kit (w/NEMA 7/9 Base)	
11	Switch Insulating Washer							
12	Housing Base							
13	Cooling Fin	Consult Factory						
14	Float Chamber Assembly	Consult Factory						

IMPORTANT: When ordering, please specify:
 A. Model and serial number of control.
 B. Name and number of replacement assembly.

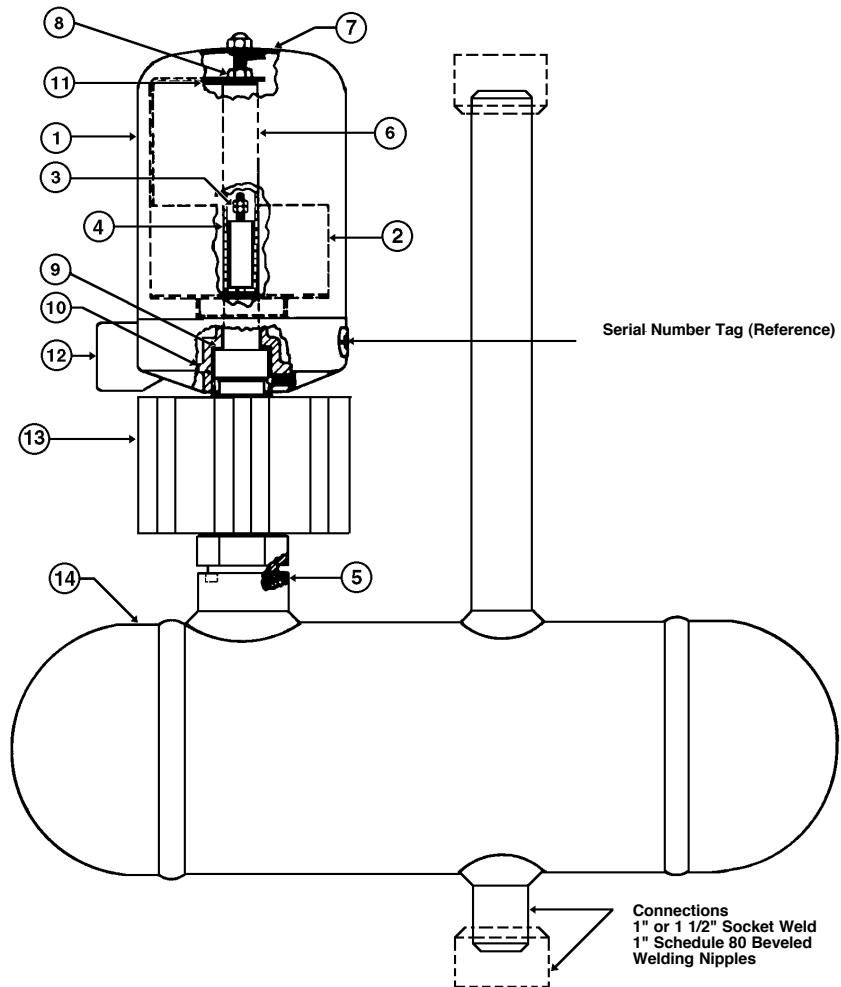

DIMENSIONAL SPECIFICATIONS IN mm (inches)

	Switch Types	V		W		ø X		Y		Z
		mm	inches	mm	inches	mm	inches	mm	inches	
Weatherproof-ATEX - FM (NEMA 7/9) - (Cast Aluminium)	F or S	257	10.12	42	1.66	151	5.93	109	4.29	M20 x 1,5 ^(*) or 1" NPT (2 entries - 1 plugged) ^(*) not for FM (NEMA 7/9)
Weatherproof-(Alu/Steel)	L	216	8.50	39	1.54	118	4.65	83	3.27	3/4" NPT (single entry)
NEMA 7/9-(Cast Iron)		246	9.68	42	1.66	143	5.63	100	3.94	1" NPT (single entry)

Allow 200 mm (7.87") overhead clearance / All housings are 360 ° rotatable

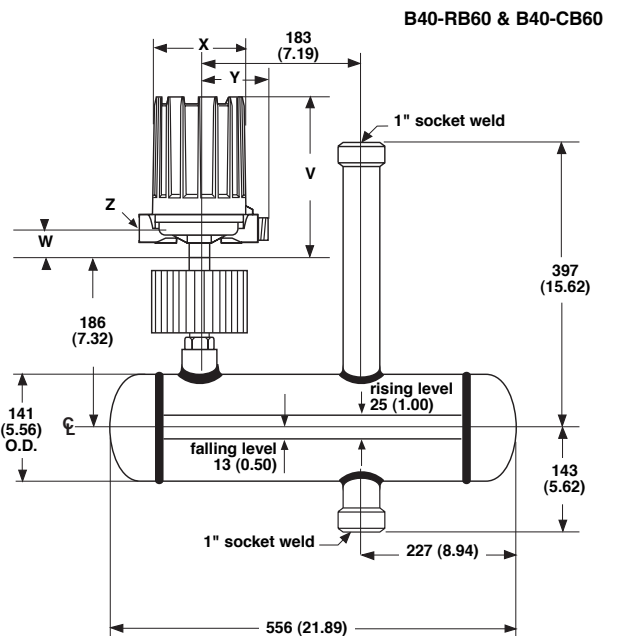
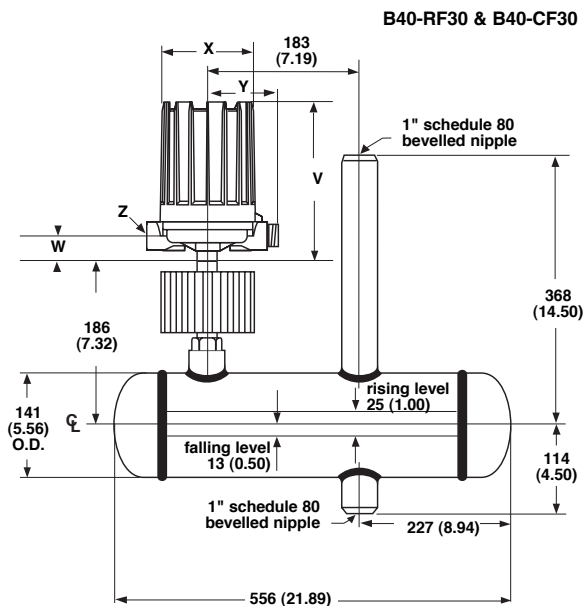
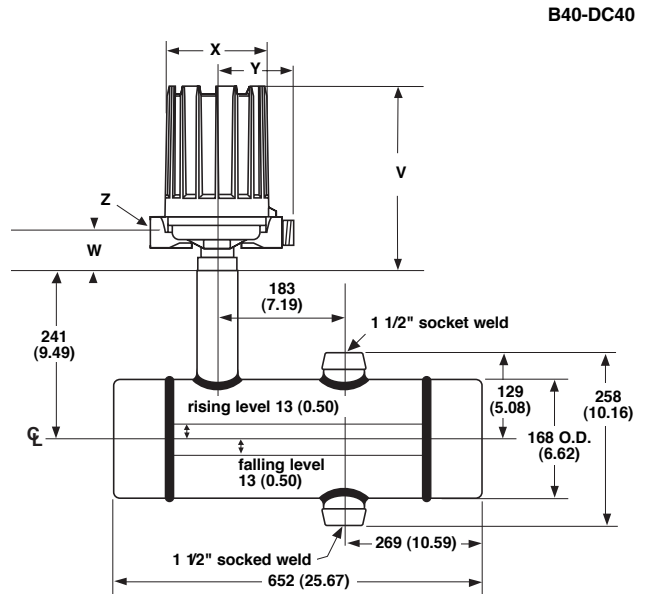
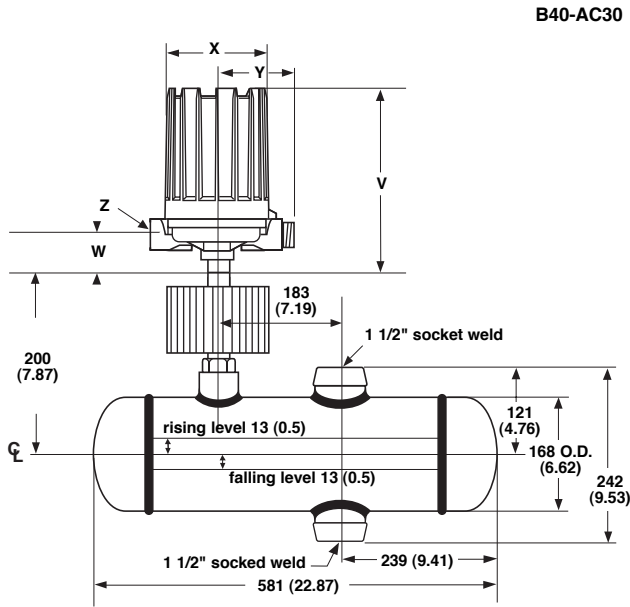

IMPORTANT

SERVICE POLICY

Owners of Magnetrol products may request the return of a control; or, any part of a control for complete rebuilding or replacement. They will be rebuilt or replaced promptly. Magnetrol International will repair or replace the control, at no cost to the purchaser, (or owner) **other than transportation cost** if:

- a. Returned within the warranty period; and,
- b. The factory inspection finds the cause of the malfunction to be defective material or workmanship.

If the trouble is the result of conditions beyond our control; or, is **NOT** covered by the warranty, there will be charges for labour and the parts required to rebuild or replace the equipment.

In some cases, it may be expedient to ship replacement parts; or, in extreme cases a complete new control, to replace the original equipment before it is returned. If this is desired, notify the factory of both the model and serial numbers of the control to be replaced. In such cases, credit for the materials returned, will be determined on the basis of the applicability of our warranty.

No claims for misapplication, labour, direct or consequential damage will be allowed.

RETURNED MATERIAL PROCEDURE

So that we may efficiently process any materials that are returned, it is essential that a "Return Material Authorisation" (RMA) form will be obtained from the factory. It is mandatory that this form will be attached to each material returned. This form is available through Magnetrol's local representative or by contacting the factory. Please supply the following information:

1. Purchaser Name
2. Description of Material
3. Serial Number
4. Desired Action
5. Reason for Return
6. Process details

All shipments returned to the factory must be by prepaid transportation. Magnetrol **will not accept** collect shipments.

All replacements will be shipped FOB factory.

BULLETIN N°: BE 46-602.7
EFFECTIVE: JANUARY 2005
SUPERSEDES: March 1997

UNDER RESERVE OF MODIFICATIONS



www.magnetrol.com

BENELUX	Heikensstraat 6, 9240 Zele, België Tel. +32 (0)52.45.11.11 • Fax. +32 (0)52.45.09.93 • E-Mail: info@magnetrol.be
DEUTSCHLAND	Alte Ziegelei 2-4, D-51491 Overath Tel. 02204 / 9536-0 • Fax. 02204 / 9536-53 • E-Mail: vertrieb@magnetrol.de
FRANCE	40 - 42, rue Gabriel Péri, 95130 Le Plessis Bouchard Tél. 01.34.44.26.10 • Fax. 01.34.44.26.06 • E-Mail: magnetrolfrance@magnetrol.fr
ITALIA	Via Arese 12, I-20159 Milano Tel. (02) 607.22.98 (R.A.) • Fax. (02) 668.66.52 • E-Mail: mit.gen@magnetrol.it
UNITED KINGDOM	Unit 1 Regent Business Centre, Jubilee Road Burgess Hill West Sussex RH 15 9TL Tel. (01444) 871313 • Fax (01444) 871317 • E-Mail: sales@magnetrol.co.uk
INDIA	E-22, Anand Niketan, New Delhi - 110 021 Tel. 91 (11) 6186211 • Fax 91 (11) 6186418 • E-Mail: info@magnetrolindia.com