



B73 External Cage Liquid Level Switches

INSTRUCTION MANUAL AND PARTS LIST

DESCRIPTION

B73 instruments are float operated liquid level controls designed for external float cage mounting. These instruments are ideally used for off-on liquid level control, alarm and safety shut-down service in a wide variety of applications including large steam-electric generating stations, oil refineries and chemical processing operations. The B73 is available with either a carbon steel or stainless steel float cage and is suitable for service pressure ratings up to 20.7 bar (300 PSIG) and specific gravity ratings down to 0.60.

OPERATING PRINCIPLE

A permanent magnet is attached to a pivoted switch mechanism. As the float rises following the liquid level, it raises the magnet attractor into the field of the magnet, which in turn snaps against the non-magnetic barrier tube, tilting the switch mechanism. The barrier tube provides a static seal between the switch mechanism and the float.

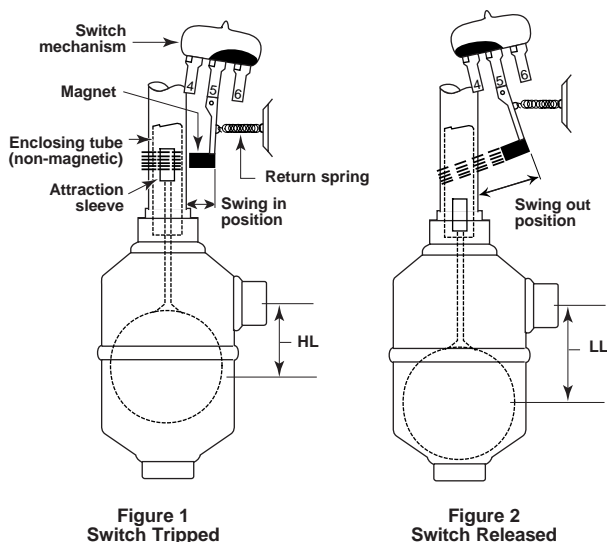

Figure 1
Switch Tripped

Figure 2
Switch Released

OPERATING CYCLE

As the liquid level rises in the chamber, refer to Figure 1, the float moves the magnetic attraction sleeve up within the enclosing tube and into the field of the switch mechanism magnet. As a result, the magnet is drawn in tightly to the enclosing tube causing the switch to trip, making or breaking an electrical circuit. As the liquid level falls, the float drops and moves the attraction sleeve out of the magnetic field, releasing the switch at a predetermined low level. Refer to Figure 2. The tension spring ensures the return of the switch in a snap action.



AGENCY APPROVALS

Agency	Approval ①
CENELEC	EEx d IIC T6, explosion proof EEx ia IIC T6, intrinsically safe ^②
BASEEFA	Ex d IIC T6
CSA ①	Non-Hazardous CSA Type 4X Class I, Div. 2, Groups B, C & D Class I, Div. 1, Groups C & D Class II, Div. 1, Groups E, F & G Class I, Div. 1, Groups B, C & D Class II, Div. 1, Groups E, F & G
FM ①	Non-Hazardous NEMA 4X Class I, Div. 1, Groups C & D Class II, Div. 1, Groups E, F & G Class I, Div. 1, Groups B, C & D, Class II, Div. 1, Groups E, F & G
SAA ①	Ex d IIC T6 (IP65)

① Not available with all switches; Consult factory for proper model numbers.

② Consult factory for proper model numbers.

INSTALLATION

CRITICAL ALARM FUNCTION

It is recommended that for critical alarm functions, an additional level switch be installed as a high-high or low-low level alarm for maximum protection.

PIPING

Figure 3 shows a typical piping installation of a Magnetrol level switch to a pressure vessel. Reference mark on float chamber should be aligned with liquid level in vessel at which switch control is desired.

Use pipe of sufficient strength to support the control. If necessary, provide a stand or hanger to help support its weight. All piping should be straight and free of "low spots" or "pockets" so that lower liquid line will drain towards the vessel and upper vapor line will drain toward the control. Shut-off valves are recommended for installation between the vessel and the control. If control is to be used with a lower temperature liquid (one which will "boil" in the float chamber if outside heat is absorbed), the chamber and piping should be insulated. Such boiling in the chamber will cause false level indications. **DO NOT INSULATE SWITCH MECHANISM HOUSING.**

On controls equipped with pneumatic switch assemblies, consult bulletin on mechanism furnished for air (or gas) piping instructions. Refer to chart on this page for bulletin numbers for pneumatic switches.

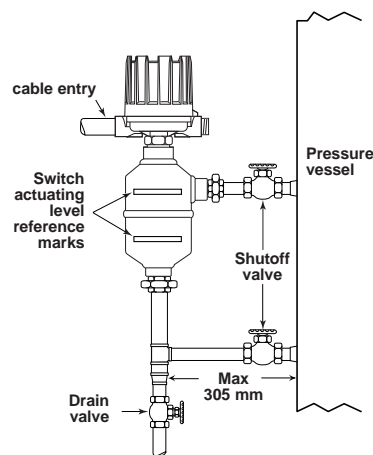

Figure 3

MOUNTING

Adjust piping as required to bring control to a vertical position. Magnetrol controls must be mounted within three (3°) degrees of vertical. A three degree slant is noticeable by eye, but installation should be checked with a spirit level on top and/or sides of float chamber.

Controls should be mounted as close to the vessel as possible. This will result in a more responsive and accurate level change in the control. Liquid in a long line may be cooler and more dense than liquid in the vessel causing lower level indication in the control than actual level in the vessel.

WIRING

Most mechanical control switch housings are designed to allow 360° positioning of the cable entries by loosening the set screw(s). See **figure 4**. On high temperature applications (above 120° C [250° F]), high temperature wire should be used between control and first junction box located in a cooler area.

1. To gain access to switch mechanism(s) remove switch housing cover. (See CAUTION next page.)
2. Pull in supply wires (conductors), wrap them around enclosing tube under the baffle plate and connect to proper terminals. Be certain that excess wire does not interfere with "tilt" of switch and that adequate clearance exists for replacement of switch housing cover.

NOTE: See bulletin on switch mechanism furnished with your control (as listed below) for proper connections.

3. Connect power supply to control and test switch action by varying liquid level in tank or vessel.

CAUTION:

In hazardous area, do not power the unit until the cable gland is sealed and the enclosure cover is screwed down securely.

NOTE: If switch mechanism fails to function properly, check vertical alignment of control housing and consult installation instructions in switch mechanism bulletin.

4. Replace switch housing cover and place control into service.

NOTE: If control has been furnished with an explosion proof (cast) or moisture proof (gasketed) switch housing, check the following:

- After wiring connections have been completed, housings must be sealed via the correct cable gland to prevent entrance of air.
- Check cover to base fit, to be certain gasketed joint is tight. A positive seal is necessary to prevent infiltration of moisture laden air or corrosive gases into switch housing.

Switch mechanism	Bulletin	Reference series
Mercury switches	42-783	A
Dry contact switches	42-683	B, C, D, U, W, X
Anti-vibration mercury switches		E
Anti-vibration dry contact switches	42-684	G, H, I
Bleed type pneumatic valve	42-685	J
Non-bleed type pneumatic valve	42-686	K

WIRING (cont.)

OBSERVE ALL APPLICABLE ELECTRICAL CODES AND PROPER WIRING PROCEDURES

NEMA 4x

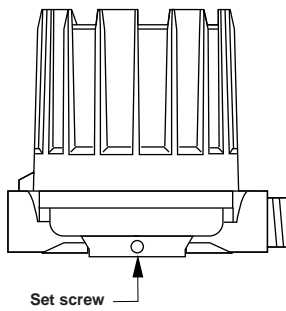

Figure 4a

CENELEC/BASEEFA

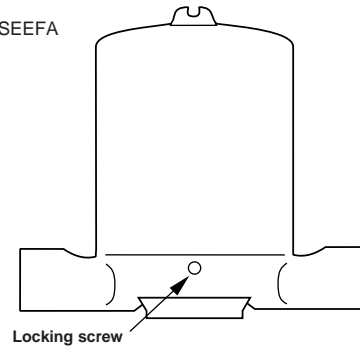

Figure 4c

NEMA 7/9

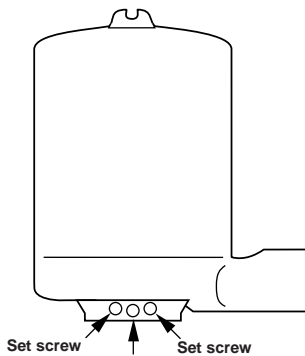

Figure 4b

CAUTION:

- DO NOT attempt to reposition NEMA 4 / NEMA 7/9 housings without loosening the set screws; CENELEC/BASEEFA housings MAY NOT BE REPOSITIONED. ALWAYS retighten set screw(s) after repositioning.
- DO NOT attempt to unscrew cover of CENELEC/BASEEFA housings before loosening locking screw in base of housing. ALWAYS retighten locking screw after replacing cover.

PREVENTIVE MAINTENANCE

Periodic inspections are a necessary means to keep your Magnetrol level control in good working order. This control is, in reality, a safety device to protect the valuable equipment it serves. Therefore, a systematic program of "Preventive Maintenance" should be implemented when control is placed into service. If the following sections on "What to Do" and "What to Avoid" are observed, your control will provide reliable protection of your capital equipment.

WHAT TO DO

1. Keep Control Clean

Be sure the switch housing cover is always in place on the control. This cover is designed to keep dust and dirt from interfering with switch mechanism operation. In addition, it protects against damaging moisture and acts as a safety feature by keeping bare wires and terminals from being exposed. Should the housing cover become damaged or misplaced, order a replacement immediately.

2. Inspect Switch Mechanisms, Terminals and Connections Monthly

- Mercury switches may be visually inspected for short circuit damage. Check for small cracks in the glass tube containing the mercury. Such cracks can allow entrance of air into the tube causing the mercury to "oxidize". This is noticeable as the mercury will appear dirty and have a tendency to "string out" like water, instead of breaking into clean round pools. If these conditions exist, replace the mercury switch immediately.
- Dry contact switches should be inspected for excessive wear on actuating lever or misalignment of adjusting screw at point of contact between screw and lever. Such wear can cause false switch actuating levels. Adjust switch mechanism to compensate (if possible) or replace switch.

DO NOT operate your control with defective maladjusted switch mechanisms (refer to bulletin on switch mechanism furnished for service instructions).

- Magnetrol controls may sometimes be exposed to excessive heat or moisture. Under such conditions, insulation on electrical wires may become brittle, eventually breaking or peeling away. The resulting "bare" wires can cause short circuits. Check wiring carefully and replace at first sign of brittle insulation.
- Vibration may sometimes cause terminal screws to work loose. Check all terminal connections to be certain that screws are tight.
- On units with pneumatic switches, air (or gas) operating medium lines subjected to vibration, may eventually crack or become loose at connections causing leakage. Check lines and connections carefully and repair or replace, if necessary.

NOTE: As a matter of good practice, spare switches should be kept on hand at all times.

3. Inspect Entire Unit Periodically

Isolate control from vessel. Raise and lower liquid level to check for switch contact and reset.

PREVENTIVE MAINTENANCE (cont.)

WHAT TO AVOID

1. **NEVER** leave switch housing cover off the control longer than necessary to make routine inspections.
2. **NEVER** place a jumper wire across terminals to “cut-out” the control. If a “jumper” is necessary for test purposes, be certain it is removed before placing control into service.

3. **NEVER** attempt to make adjustments or replace switches without reading instructions carefully. Certain adjustments provided for in Magnetrol controls should not be attempted in the field. When in doubt, consult the factory or your local Magnetrol representative.
4. **NEVER** use lubricants on pivots of switch mechanisms. A sufficient amount of lubricant has been applied at the factory to ensure a lifetime of service. Further oiling is unnecessary and will only tend to attract dust and dirt which can interfere with mechanism operation.

TROUBLE SHOOTING

Usually the first indication of improper operation is failure of the controlled equipment to function i.e. pump will not start (or stop); signal lamps fail to light, etc. When these symptoms occur, whether at time of installation or during routine service thereafter, check the following potential external causes first.

- Fuses may be blown.
- Reset button(s) may need resetting.
- Power switch may be open.
- Controlled equipment may be faulty.
- Wiring or medium lines leading to control may be defective.

If a thorough inspection of these possible conditions fails to locate the trouble, proceed next to a check of the controls switch mechanism.

CHECK SWITCH MECHANISM

1. Pull disconnect switch or otherwise assure disconnect power to the control.
2. Remove switch housing cover.
3. Disconnect power wiring from switch assembly.
4. Swing magnet assembly in and out by hand to check carefully for any sign of binding. Assembly should require minimal force to move it through its full swing.
5. If binding exists, magnet may be rubbing enclosing tube. If magnet is rubbing, loosen magnet clamp screw and shift magnet position. Retighten magnet clamp screw.
6. If switch magnet assembly swings freely and mechanism still fails to actuate, check installation of control to be certain it is within the specified three (3°) degrees of vertical (use spirit level on side of enclosing tube in two places, 90° apart).
7. If mechanism is equipped with a mercury switch, examine glass mercury tube closely as previously described in “Preventive Maintenance” section. If switch is damaged, replace it immediately.
8. If switch mechanism is operating satisfactorily, proceed to check sensing unit.

CHECK SENSING UNIT

1. Check to be certain liquid is entering float chamber. A valve may be closed or piping plugged.
2. Proceed to check level sensing action.

CAUTION: Unit must be normalized to atmospheric pressure before removing switch housing assembly.

3. Remove the switch housing assembly by loosening the enclosing tube nut located immediately below the housing base.
4. Inspect attraction sleeve(s) and inside of enclosing tube for excessive corrosion or solids build-up which could restrict movement, preventing sleeve(s) from reaching field of magnet(s).
5. Fill chamber with liquid at room pressure. Check float(s) to be certain it is buoyant in the liquid (float chamber must have adequate liquid level). If float is determined to be filled with liquid or collapsed, entire float chamber assembly (sensing unit) should be replaced.

CHECK COMPLETE UNIT

Reassemble the unit. Reconnect the power supply and carefully actuate the switch mechanism manually (using a non-conductive tool) to determine whether controlled equipment will operate.

CAUTION: With electrical power “on”, care should be taken to avoid contact with switch leads and connections at terminal block.

If all components in the control are in operating condition, the trouble must be (and should be) located external to the control. Repeat inspection of external conditions previously described.

NOTE: If difficulties are encountered which can not be identified, consult with the factory or your local representative for assistance. A complete description of the trouble should be provided along with information concerning your piping and mounting arrangement, plus a description of your operation sequence. Sketches or photographs showing the installation are also beneficial.

When communicating about your control, be certain always to specify the complete Model and Serial numbers.

REPLACEMENT PARTS

Item	Description	Replacement part number		
1	Housing Cover	Housing Kits	Refer to bulletin 42-680/42-780 for Switch Housing Cover and Base Assemblies	
2	Housing Base			
3	Switch Mechanism	Refer to bulletin on Switch Mechanism furnished. (Listed on Page 3.)		
4	Jam Nuts	Sleeve Kit ①	89-3409-001 Standard Construction 89-3410-009 Stainless Steel Connection	
5	Guide Washer			
6	Attraction Sleeve			
7	Enclosing Tube		Models with material code 1 & 2	Models with material code 3 & 4
		Nema 4X, Nema 7 & 9, Pneumatic Switch Housing	32-6302-031	32-6302-036
		Baseefa & Cenelec	32-6344-002	32-6344-001
8	E-Tube Gasket	12-1301-002		
9	Chamber Assembly	Chamber assemblies are available as complete sensing units ONLY with all parts listed under items 4 through 9 assembled.		

① Standard construction kit includes attraction sleeve of type 400 series stainless steel. Stainless steel construction kit includes sheathed attraction sleeve used on models for corrosive service.

IMPORTANT: Many B73 controls are specially tailored to meet specific customer specifications and therefore may contain special parts. When ordering specify:

- A. Model and Serial Number of Control**
- B. Replacement Part Number**

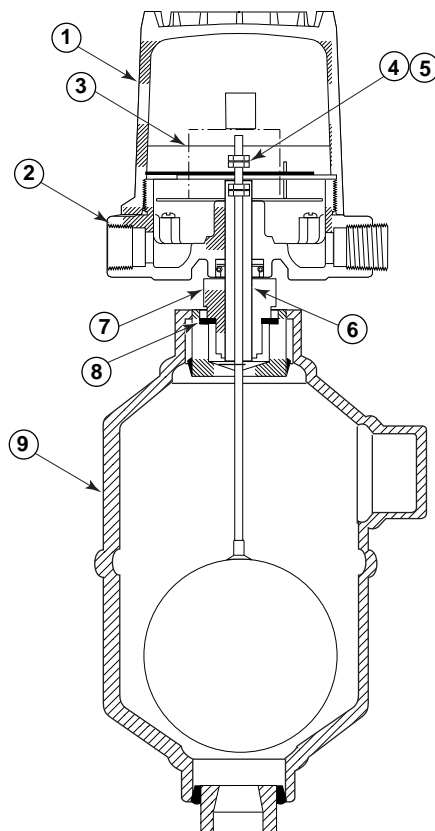

DIMENSIONAL SPECIFICATIONS in mm (inches)

OUTLINE DIMENSIONS IN mm (inches)

Housing	(A)	(B)	Entry (C)	max (D) ④
IP 65 (NEMA 4x)	151 (5.93)	109 (4.29)	1" NPT, M20 x 1.5 or PG16 (2 entries - 1 plugged)	459 (18.07)
NEMA 7/9 (IP 65)	143 (5.63)	100 (3.94)	1" NPT - 1 entry	453 (17.83)
CENELEC/BASEEFA (IP 66)	143 (5.63)	110 (4.33)	3/4" NPT OR M20 x 1.5 - 2 entries	507 (19.80)
NEMA 3R (IP 53) Pneumatic K	118 (4.64)	130 (5.12)	1/4" NPT - 2 entries	423 (16.65)
NEMA 3R Pneumatic J	118 (4.64)	110 (4.33)	1/4" NPT - 1 entry	423 (16.65)

④ Allow ± 3 (0.12) tolerances on dimensions and allows 203 (8.00) overhead clearance for cover removal

ACTUATING LEVEL DIMENSIONS VS. SPECIFIC GRAVITY – mm (inches)

Dimensions	Specific gravity			
	0.60	0.80	1.00	1.20
HL	30 (1.22)	43 (1.69)	49 (1.93)	54 (2.13)
LL	53 (2.10)	60 (2.36)	65 (2.56)	68 (2.68)

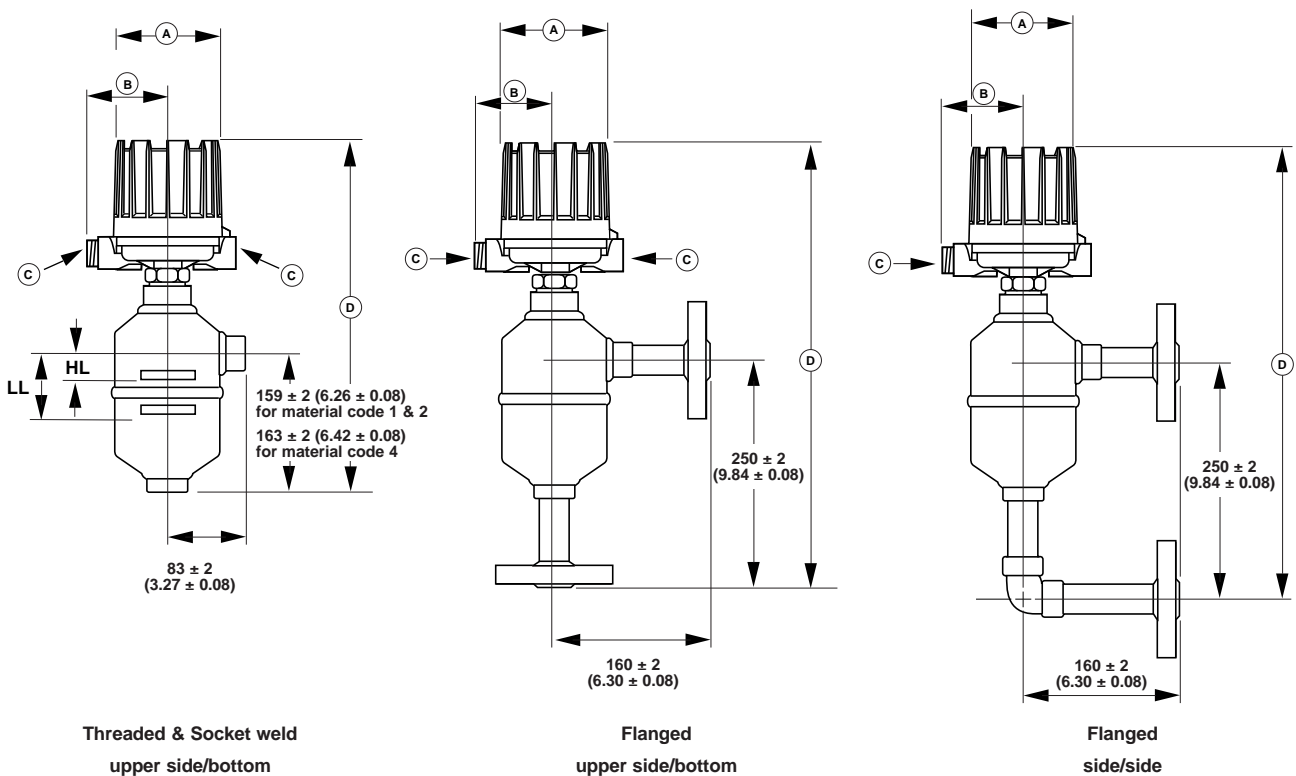

IMPORTANT

SERVICE POLICY

Owners of Magnetrol products may request the return of a control; or, any part of a control for complete rebuilding or replacement. They will be rebuilt or replaced promptly. Magnetrol International will repair or replace the control, at no cost to the purchaser, (or owner) **other than transportation cost** if:

- a. Returned within the warranty period; and,
- b. The factory inspection finds the cause of the malfunction to be defective material or workmanship.

If the trouble is the result of conditions beyond our control; or, is **NOT** covered by the warranty, there will be charges for labour and the parts required to rebuild or replace the equipment.

In some cases, it may be expedient to ship replacement parts; or, in extreme cases a complete new control, to replace the original equipment before it is returned. If this is desired, notify the factory of both the model and serial numbers of the control to be replaced. In such cases, credit for the materials returned, will be determined on the basis of the applicability of our warranty.

No claims for misapplication, labour, direct or consequential damage will be allowed.

RETURNED MATERIAL PROCEDURE

So that we may efficiently process any materials that are returned, it is essential that a "Return Material Authorisation" (RMA) form will be obtained from the factory. It is mandatory that this form will be attached to each material returned. This form is available through Magnetrol's local representative or by contacting the factory. Please supply the following information:

1. Purchaser Name
2. Description of Material
3. Serial Number
4. Desired Action
5. Reason for Return
6. Process details

All shipments returned to the factory must be by prepaid transportation. Magnetrol **will not accept** collect shipments.

All replacements will be shipped FOB factory.

BULLETIN N°: BE 46-621.1
EFFECTIVE: NOVEMBER 1996
SUPERSEDES: March 1991

UNDER RESERVE OF MODIFICATIONS



BELGIUM	Heikensstraat 6, 9240 Zele Tel. (052) 45.11.11	Fax (052) 45.09.93
DEUTSCHLAND	Schloßstraße 76, D-51429 Bergisch Gladbach-Bensberg Tel. (02204) 9536-0	Fax (02204) 9536-53
FRANCE	11, Rue A. Einstein, Espace Descartes, 77420 Champs-sur-Marne adresse postale: 77436 Marne-la-Vallée Cédex 2 Tel. (0) 164.68.58.28	Fax (0) 164.68.58.27
ITALIA	Via Arese 12, I-20159 Milano Tel. (02) 607.22.98 (R.A.)	Fax (02) 668.66.52
UNITED KINGDOM	Unit 1 Regent Business Centre Jubilee Road Burgess Hill West Sussex RH 15 9TL Tel. (01444) 871313	Fax (01444) 871317
INDIA	B4/115 Safdurjung Enclave, New Delhi 110 029 Tel. 91 (11) 6186211	Fax 91 (11) 6186418