



F10

Vane type flow switches

INSTRUCTION MANUAL AND PARTS LIST

DESCRIPTION

The F10 is a vane type flow switch designed to be installed in 2" through 30" horizontal pipeline by means of a threaded or flanged connection.

PART NUMBER CONSTRUCTION

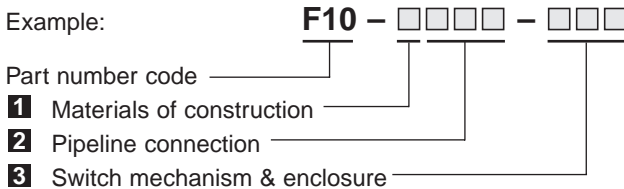

1 Materials of construction

Code	Mounting connection material	Trim	Sleeve
1	Carbon steel	304 SS	Sheathed magnetic sleeve
3	304 stainless	&	
4	316 stainless	316 SS	

2 Select pipeline connection

Connection	Code vane sized flow line ①				
	2"	4"	6"	8"	10"
2" NPT	D22	D24	D26	D28	D20
2 1/2" 150 lb. ANSI R.F. flange ②	-	E54	E56	E58	E50
2 1/2" 300 lb. ANSI R.F. flange	-	E64	E66	E68	E60
2 1/2" 600 lb. ANSI R.F. flange	-	E74	E76	E78	E70

① For flow lines above 10" consult factory.

② For larger flanges consult factory.

3 Select pneumatic switch mechanism & housing

Switch description	Max. supply pressure	Max. process temperature	Bleed orifice diameter	Code (NEMA 1 enclosure)
Series J Bleed	6.9 bar (100 PSIG)	200°C (400°F)	1.60 mm (0.063")	JGF
	4.1 bar (60 PSIG)		2.39 mm (0.094")	JHF
	4.1 bar (60 PSIG)	230°C (450°F)	1.40 mm (0.055")	JJF
Series K Non-bleed	6.9 bar (100 PSIG)	200°C (400°F)	-	KOF
	(2.8 bar) (40 PSIG)			KOH

③ Housing heater and drain available in option. Consult factory for proper model numbers.

④ Process temperatures are based upon +38°C (100°F) ambient.

3 Select electric switch mechanism & enclosure

Switch description	Max. process temp. °C (°F) ④	Cont. one per encl.	Switch enclosure ③					
			NEMA 4X cast aluminium			NEMA 7/9 cast iron		CENELEC cast iron
			1" NPT	M 20 x 1.5	PG 16	1" NPT	M20 x 1.5	3/4" NPT
Series A - Mercury switch	230°C (450°F)	SPDT	AAB	A2B	A3B	AKM	AK5	AU5
			DPDT	ADB	A8B	A9B	ANM	AD5
Series B - Snap switch	120°C (250°F)	SPDT	BAB	B2B	B3B	BKM	BK5	BU5
			DPDT	BDB	B8B	B9B	BNM	BD5
Series C - Snap switch	230°C (450°F)	SPDT	CAB	C2B	C3B	CKM	CK5	CU5
			DPDT	CDB	C8B	C9B	CNM	CD5
Series D - Snap switch for DC current	120°C (250°F)	SPDT	DAB	D2B	D3B	DKM	DK5	DU5
			DPDT	DDB	D8B	D9B	DNM	DD5
Series E - Vibr. resistant mercury switch	230°C (450°F)	SPDT	EAB	E2B	E3B	EKM	EK5	EU5
			DPDT	EDB	E8B	E9B	ENM	ED5
Series HS - Hermetically sealed with terminal block	288°C (550°F)	SPDT	HM2	H7A	H6A	HS3	HB3	HB4
			DPDT	HM6	H7C	H6C	HS7	HB7
Series U - Snap switch	120°C (250°F)	SPDT	UAB	U2B	U3B	UKM	UK5	UU5
			DPDT	UDB	U8B	U9B	UNM	UD5
Series W - Snap switch hermetically sealed	120°C (250°F)	SPDT	WAB	W2B	W3B	WKM	WK5	WU5
			DPDT	WDB	W8B	W9B	WNM	WD5
Series X - Snap switch hermetically sealed	230°C (450°F)	SPDT	XAB	X2B	X3B	XKM	XK5	XU5
			DPDT	XDB	X8B	X9B	XNM	XD5

OPERATING PRINCIPLE

The actuating vane is magnetically linked to a pivoted electric (or pneumatic) switch, which is isolated from the process by a non-magnetic barrier tube. As the actuating vane moves with an increase in flow, it drives a magnetic sleeve ① into the field of a permanent magnet ② located outside the barrier tube ③ which trips the switch. As flow decreases, the actuating vane returns to a vertical position, allowing the magnet and switch assembly to return to the "No Flow" position.

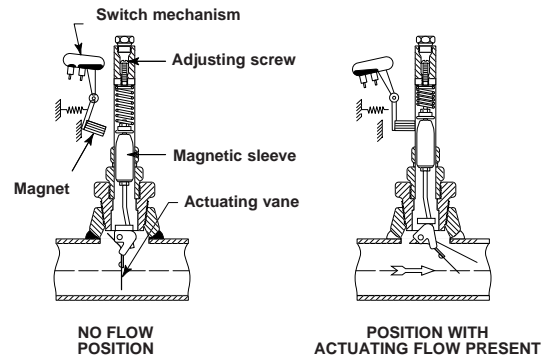

Figure 1

INSTALLATION

UNPACKING

Unpack the instrument carefully. Inspect all units for damage. Report any concealed damage to the carrier within 24 hours. Check the content of the packing slip and purchase order. Check and record the serial number for future reference when ordering parts.

PIPING

The F10 flow switch should be located in a horizontal run pipe with the arrow on the body bushing or mounting flange pointing in the direction of flow.

MOUNTING — THREADED CONNECTION

A. Installation of F10 IN LINE

1. Insert a length of pipe in 2" 3,000 lb. Threadolet fitting.
2. Plumb the vertical center line of the fitting and trace around the fitting to locate center line of required 67 mm (2.62") \varnothing hole (Figure 2).

Figure 2

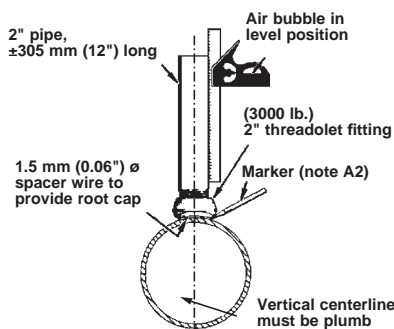

3. Clean-up inside edges of hole and remove any slag on the bottom of line that could interfere with vane.
4. With fitting concentrically positioned over the 67 mm (2.62") \varnothing hole and the vertical center line held plumb (as shown in Figure 3), tack weld the fitting at 4 equally spaced points. After tacking, remove 1.5 mm (0.06") \varnothing spacer wire (Figure 2).

Figure 3

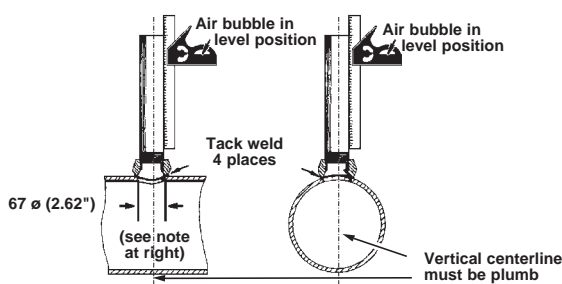

MOUNTING — THREADED CONNECTION

A. Installation of F10 in line (cont.)

NOTE: A hole in the pipeline less than 67 mm (2.62") in diameter will limit travel of the pivoted vane. If this condition cannot be avoided, the width of the vane should be reduced to 38 mm (1.50") maximum.

IMPORTANT: For installation in 2.00" pipe lines, disregard 67 mm (2.62") dimension and use inside of Threadolet as template.

5. Proper operation of the model F10 depends upon the vertical center line of the 2" NPT coupling being plumb within 3°; keep fitting plumb while welding the continuous passes according to threadolet manufacturers installation procedure.
6. With large and small vanes unassembled, tighten thread the F10 body bushing into the coupling on the pipeline until one of the 3 decal flow arrows is pointing parallel with flow.
7. Mark the bushing thread even with the top of the threadolet as a reference point for trimming vane to correct length. Remove 2 arrows not parallel with pipe.
8. Remove F10 from pipeline.
9. Check position of arrow stamped on vane support bracket. This arrow should be pointing parallel with the flow arrow on the body bushing (as shown in Figure 4). If arrows are not parallel, remove the three vane support bracket mounting screws and rotate bracket until the stamped arrow is pointing parallel with the flow arrow; replace mounting screws.

Figure 4

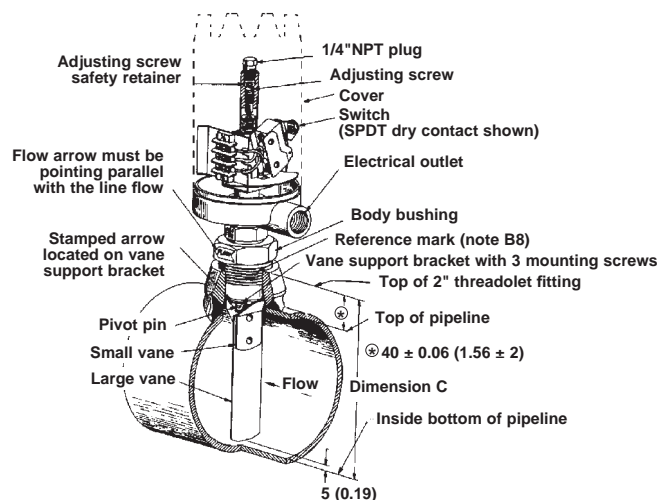

INSTALLATION (cont.)

MOUNTING — THREADED CONNECTION

C. Trimming vane to fit line size

10. The Model F10 is furnished as standard with vanes suitable for use on 2" through 30" pipelines. Assemble vane (or vanes) to F10 and trim according to applicable line size as follows:

2.00" line (SCH.40) – Use small vane only (no cutting should be necessary).

2.50" line – Use small vane with large vane trimmed to 38 mm (1.50") wide (same as small vane) and length trimmed to dimension C less 5 mm (0.19"), as shown in **Figure 5**.

3.00" line and larger – Use small vane with large vane length trimmed to dimension C less 5 mm (0.19"), as shown in **Figure 5**. Upon final assembly of trimmed vanes, firmly tighten 2 screws (item 27, page 7). It is recommended that the lower retaining screw be peened over on the threaded end.

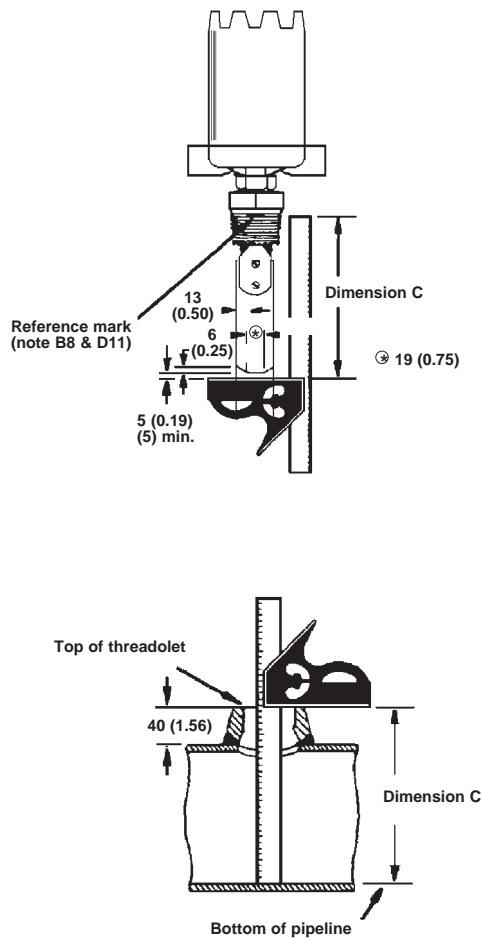

Figure 5

D. Final Mounting of F10

11. Apply sealing compound to body bushing threads.
12. Thread F10 into threadolet fitting and tighten body bushing to the same seal tight position as in note B6, so that the flow arrow is pointing parallel with the line flow.
13. Connect power lines.

MOUNTING — FLANGED CONNECTIONS

Figure 6 shows 1 method which may be used to mount the Model F10 flow switch to 2 1/2" through 30" run pipes. Before final welding, alignment of mounting flange should be checked to be certain it is plumb. Finished mounting must allow control switch housing to be within 3° degrees of vertical for proper operation. A 3° slant is noticeable by eye, but installation should be checked with a spirit level.

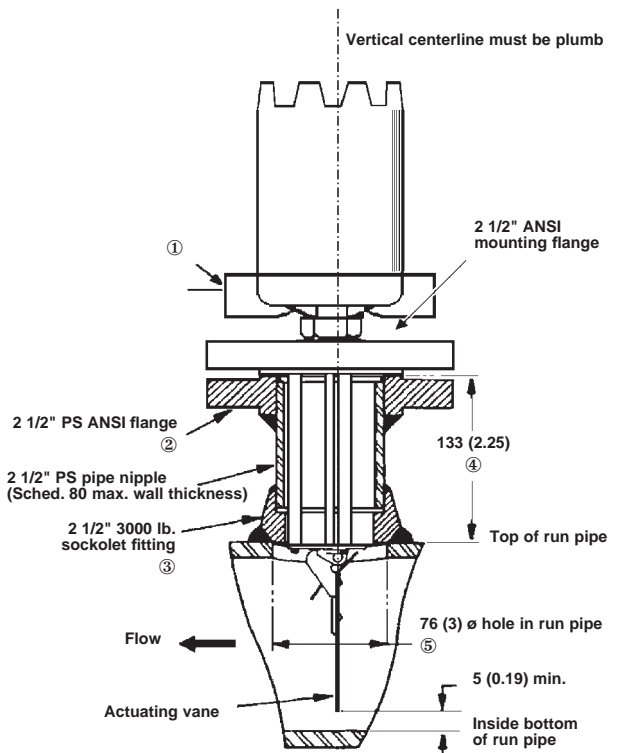

Figure 6

- ① Electrical outlet may be rotated 360° for wiring convenience.
- ② Flange to match flange of F10 flow switch and positioned with bolt holes straddling center lines.
- ③ For proper attachment procedure, refer to fitting manufacturer's recommendation.
- ④ Dimension shown is for use with 1.5 mm (0.06") thick flange gasket. If thicker gasket is used, reduce dimension amount equal to additional thickness.
- ⑤ For run pipe sizes over 2 1/2" P.S. only. For installation on 2 1/2" run pipes, disregard 3" dimension and use inside of adaptor fitting as template.
- ⑥ Follow sections B and C of MOUNTING — THREADED CONNECTION to position the vane perpendicular to the flow and trim the vane to size.

INSTALLATION (cont.)

WIRING

NOTE: All Model F10 switch housings are designed to allow 360° positioning of the electrical outlet(s) for wiring convenience by loosening the set screw(s) located under the housing base.

1. On high temperature applications (above 120°C (250°F) in pipeline), high temperature wire should be used between Magnetrol control and first junction box located in a cooler area.
2. To gain access to switch mechanism, remove switch housing cover.
3. Pull in supply wires (conductors), wrap them around enclosing tube beneath the baffle plate and connect to proper terminals. Check to be certain that excess wire does not interfere with “tilt” of switch and that adequate clearance exists for replacement of switch housing cover.
4. Connect power supply to control and test switch actuation by varying flow rate within pipeline.

NOTE: If switch mechanism fails to function properly, check vertical alignment of control housing and refer to installation bulletin on mechanism furnished, as listed below.

5. Replace switch housing cover.

NOTE: NEMA 7/9 housings, the housings must be “sealed” at the electrical outlet with suitable compound to prevent entrance of air. Check cover to base fit to be certain gasketed joint is tight. A positive seal is necessary to prevent infiltration of moisture laden air or corrosive gases into switch housing.

6. Place flow switch into service.

SWITCH ACTUATION ADJUSTMENT

The Model F10 flow switch is factory set to actuate at the minimum flow rate. Actuation flow rate can be increased while the unit is in service (under pressure) by removing the 1/4” NPT plug to gain access to the “O” ring sealed adjusting screw. Each clockwise turn of the adjusting screw increases the actuating flow rate approximately 10% of the range of the specific flow vane being used.

CAUTION: The safety retainer above the adjusting screw is there to help prevent the accidental removal of the adjusting screw. Do not defeat its purpose by forcefully backing out the adjustment screw. Be sure to replace 1/4” NPT plug and tighten firmly.

Switch mechanism	Bulletin n°	Series ref.
Mercury switches	A	42-783
Dry contact switches	B, C, D, U, W,X	
Anti-vibration mercury switches	E	
Bleed type pneumatic valve	J	42-685
Non-bleed type pneumatic valve	K	42-686

SPECIFICATIONS

Model F10 flow switch with flanged connection

Line size	Dim. X max.	Equivalent max. wall schedule
2"	46 (1.81)	80
2 1/2"	49 (1.94)	160
3"	48 (1.88)	80
3 1/2"	48 (1.88)	80
4"	51 (2.00)	120
5"	52 (2.06)	120
6"	54 (2.12)	120
8"	56 (2.19)	100
over 8"	59 (1.31)	—

Electrical connections (E)	
<i>Electrical switches:</i>	
NEMA 4X:	1" NPT – M20 x 1,5 – PG 16 (2 entries – 1 plugged)
NEMA 7/9:	1" NPT-F entry
CENELEC:	M 20 x 1,5 or 3/4" NPT-F entry
<i>Pneumatic switches:</i>	
K series:	1/4" NPT-F (2 entries)
J series:	1/4" NPT-F (1 entry)

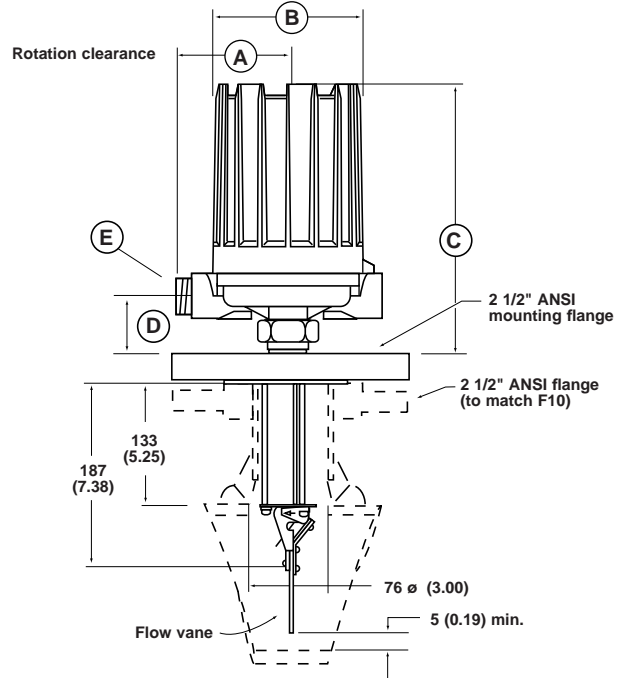

Model F10 flow switch with threaded connection

OUTLINE DIMENSIONS

Housing	Threaded mounting			
	A	B	C	D
NEMA 4X	108 (4.29)	151 (5.93)	314 (12.38)	48 (1.88)
NEMA 7/9	100 (3.94)	143 (5.63)	336 (13.23)	42 (1.65)
CENELEC	110 (4.33)	143 (5.63)	339 (13.35)	45 (1.77)
Pneum. sw. J	110 (4.33)	118 (4.64)	306 (12.05)	39 (1.53)
Pneum. sw. K	130 (5.12)	118 (4.64)	306 (12.05)	39 (1.53)
Housing	Flanged mounting			
	A	B	C	D
NEMA 4X	108 (4.29)	151 (5.93)	257 (10.12)	48 (1.88)
NEMA 7/9	100 (3.94)	143 (5.63)	246 (9.68)	42 (1.65)
CENELEC	110 (4.33)	143 (5.63)	249 (9.80)	45 (1.77)
Pneum. sw. J	110 (4.33)	118 (4.64)	216 (8.50)	39 (1.53)
Pneum. sw. K	130 (5.12)	118 (4.64)	216 (8.50)	39 (1.53)

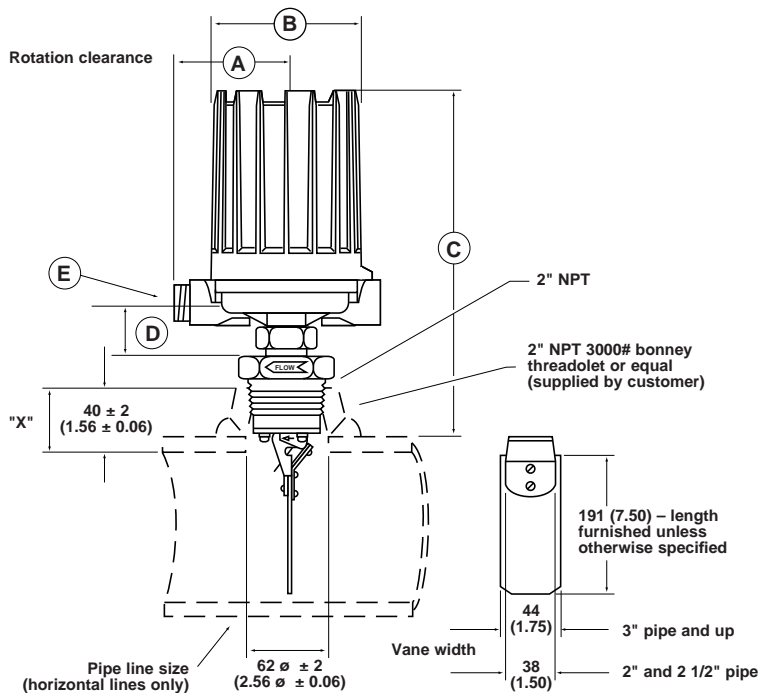

REPLACEMENT PARTS

Item no.	Description	Qty.	Carbon steel mounting	T304 SS mounting	T316 SS mounting	Forged steel flange	T304 SS flange	T316 SS flange
1	Switch housing cover	1	See bulletin 42-780 for switch housings, items 2 & 3 only applicable on steel NEMA 4 housing, see bulletin 42-680. (item 2: head screw — item 3: retaining washer)					
4	Switch housing base	1						
5	1/4-20 set screw	1						
6	Switch mechanism	1	See appropriate bulletin on switch mechanism (listed on page 4)					
7	Baffle plate assembly	1	36-5303-001					
8	6-32 round head screw	1	10-1409-005					
9	1/4-20 NPT plug	1	E-tube kit	E-tube kit	E-tube kit	E-tube kit	E-tube kit	E-tube kit
10	Safety retainer	1	89-5912-001	89-5913-001	189-5914-001	189-5928-001	89-5929-001	189-5930-001
11	Washer	1						
12	"O" ring	1						
13	Adjustment screw	1						
14	Enclosing tube	1						
15	Enclosing tube gasket	1	12-1204-001					
16a	Body bushing	1	089-5704-001	089-5705-001	189-5706-001	—		
16b	Stem. cam follower, and flange assembly	150 lb.	—			32-7203-001	32-7204-001	32-7205-001
		300 lb.				32-7203-002	32-7204-002	32-7205-002
		600 lb.				32-7203-003	32-7204-003	32-7205-003
17	Flow arrow	1	05-9822-001			—		
18	Upper spring guide	1	Stem kit 89-5541-001	Stem kit 189-5542-001	Attraction sleeve and spring kit 189-5544-001		Attraction sleeve and spring kit 189-5545-001	
19	Range spring	1						
20	10-32 hex nut	3						
21	Lower spring guide	1						
22	Attraction sleeve	1						
23	Drain washer	1						
24	Stem assembly	1			—			
25	No. 8 lockwasher	3						
26	8-32 fil. hd. screw	3						
27	8-32 rd. hd. screw	2	Vane kit 89-6703-001					
28	Small vane	1	Vaness for pipe runs over 8" are special order items. See important order note below.					
29	Large vane							
30	Instruction tag (not shown)	1	05-9816-001					

IMPORTANT:

When ordering, please specify:

- A. Model and serial number of control.
- B. Name and Number of replacement assembly.

NOTE: Consult factory for CENELEC housing.

REPLACEMENT PARTS (cont.)

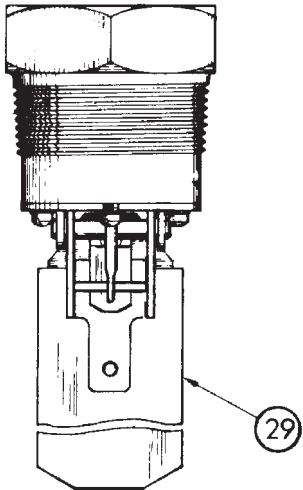
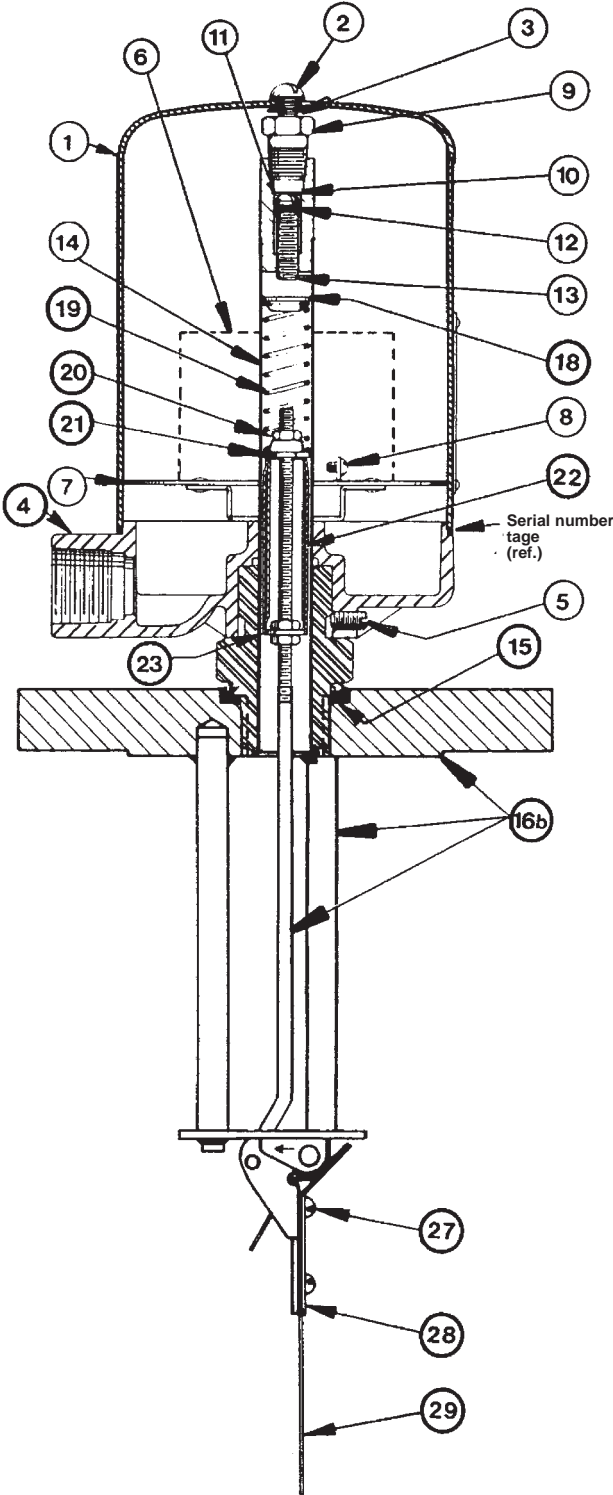
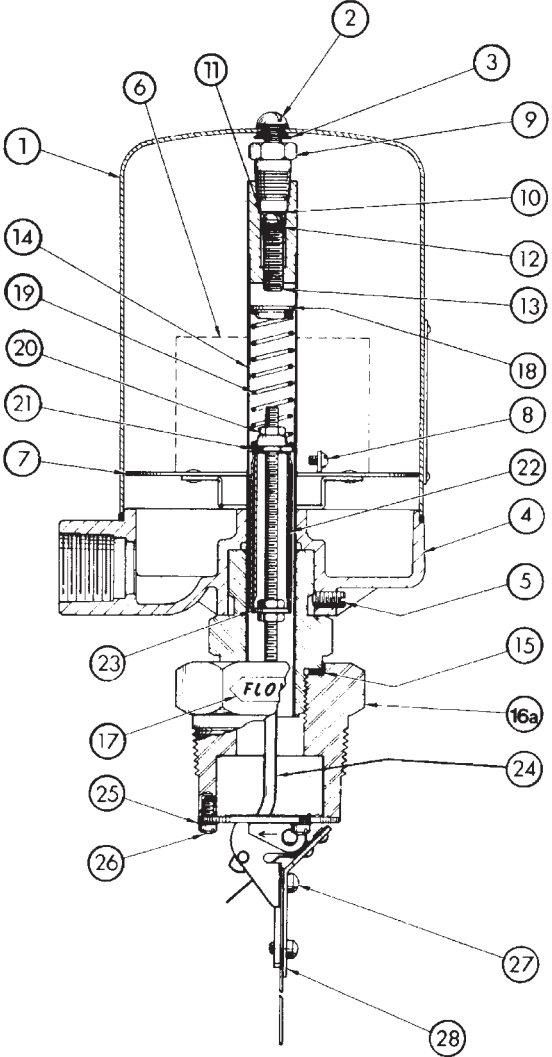

Threaded mounting

Flanged mounting

AGENCY APPROVALS

Agency	Approval
CENELEC	EEx d II C T6 (IP 66) explosion proof
	EEx ia II C T6 intrinsically safe ①
CSA ①	Non-hazardous NEMA 4X (IP 65)
	Class I, Div. 2, Groups A, B, C & D
	Class I, Div. 1, Groups C & D Class II, Div. 1, Groups E, F & G
	Class I, Div. 1, Groups B, C & D Class II, Div. 1, Groups E, F & G
FM ①	Non-Hazardous NEMA 4X (IP 65)
	Class I, Div. 1, Groups C & D Class II, Div. 1, Groups E, F & G
	Class I, Div. 1, Groups A, B, C & D Class II, Div. 1, Groups E, F & G
SAA ①	Ex d II C T6 (IP 65)

① Consult factory for proper model numbers.

IMPORTANT

SERVICE POLICY

Owners of Magnetrol products may request the return of a control; or, any part of a control for complete rebuilding or replacement. They will be rebuilt or replaced promptly. Magnetrol International will repair or replace the control, at no cost to the purchaser, (or owner) **other than transportation cost** if:

- a. Returned within the warranty period; and,
- b. The factory inspection finds the cause of the malfunction to be defective material or workmanship.

If the trouble is the result of conditions beyond our control; or, is **NOT** covered by the warranty, there will be charges for labour and the parts required to rebuild or replace the equipment.

In some cases, it may be expedient to ship replacement parts; or, in extreme cases a complete new control, to replace the original equipment before it is returned. If this is desired, notify the factory of both the model and serial numbers of the control to be replaced. In such cases, credit for the materials returned, will be determined on the basis of the applicability of our warranty.

No claims for misapplication, labour, direct or consequential damage will be allowed.

RETURNED MATERIAL PROCEDURE

So that we may efficiently process any materials that are returned, it is essential that a "Return Material Authorisation" (RMA) form will be obtained from the factory. It is mandatory that this form will be attached to each material returned. This form is available through Magnetrol's local representative or by contacting the factory. Please supply the following information:

1. Purchaser Name
2. Description of Material
3. Serial Number
4. Desired Action
5. Reason for Return
6. Process details

All shipments returned to the factory must be by prepaid transportation. Magnetrol **will not accept** collect shipments. All replacements will be shipped FOB factory.

BULLETIN N°: BE 47-602.14
EFFECTIVE: AUGUST 1995
SUPERSEDES: July 1991

UNDER RESERVE OF MODIFICATIONS



BELGIUM	Heikensstraat 6, 9240 Zele Tel. (052) 45.11.11	Fax (052) 45.09.93
DEUTSCHLAND	Schloßstraße 76, D-51429 Bergisch Gladbach-Bensberg Tel. (02204) 9536-0	Fax (02204) 9536-53
FRANCE	11, Rue A. Einstein, Espace Descartes, 77420 Champs-sur-Marne adresse postale: 77436 Marne-la-Vallée Cédex 2 Tel. (0) 164.68.58.28	Fax (0) 164.68.58.27
ITALIA	Via Arese 12, I-20159 Milano Tel. (02) 607.22.98 (R.A.)	Fax (02) 668.66.52
UNITED KINGDOM	Unit 1 Regent Business Centre Jubilee Road Burgess Hill West Sussex RH 15 9TL Tel. (01444) 871313	Fax (01444) 871317
INDIA	B4/115 Safdurjung Enclave, New Delhi 110 029 Tel. 91 (11) 6186211	Fax 91 (11) 6186418