

CAUTION: PROCEDURE FOR REMOVAL OF CENELEC HOUSING.

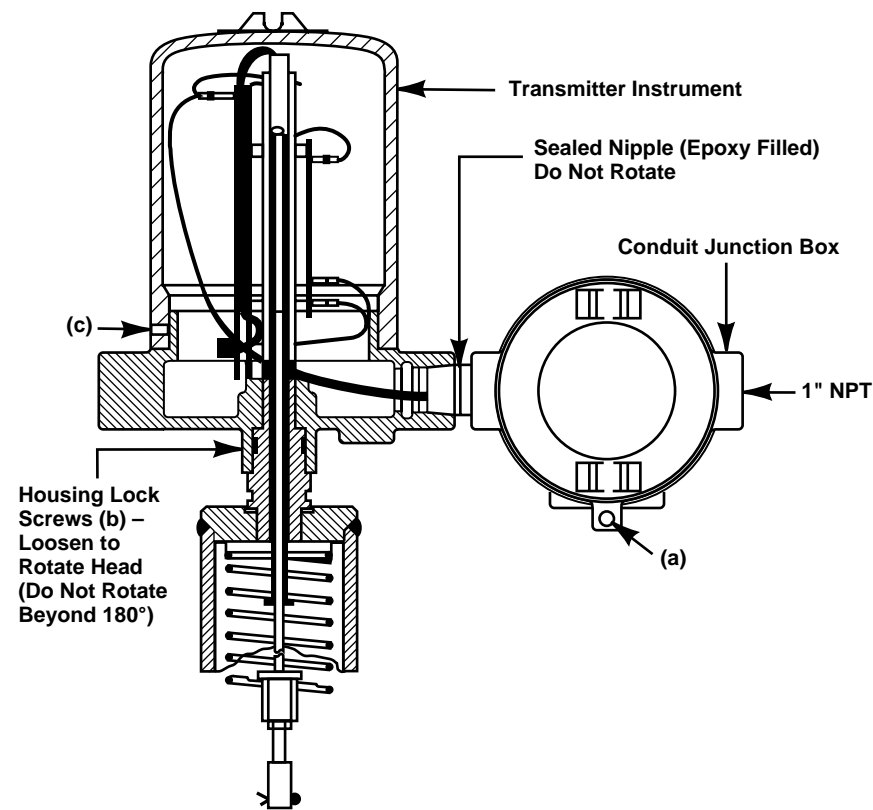

TO REMOVE METER COVER:

1. Loosen lock screws (a) (b).
2. Block with a wrench the position of the E-tube.
3. Unscrew cover.

TO ROTATE THE HOUSING:

1. Block with a wrench the position of the E-tube.
2. Loosen both lock screws (b) at base of switch housing.
3. This will allow to rotate the housing 360° for correct positioning of the electrical connections.

TO REMOVE HOUSING COVER:

1. Block with a wrench the position of the E-tube.
2. Loosen the lock screw (c) at cover.
3. Unscrew housing cover.



QUALITY ASSURANCE - ISO 9001

THE QUALITY ASSURANCE SYSTEM IN PLACE AT MAGNETROL GUARANTEES THE HIGHEST LEVEL OF QUALITY DURING THE DESIGN, THE CONSTRUCTION AND THE SERVICE OF CONTROLS. OUR QUALITY ASSURANCE SYSTEM IS APPROVED AND CERTIFIED TO ISO 9001 AND OUR TOTAL COMPANY IS COMMITTED TO PROVIDING FULL CUSTOMER SATISFACTION BOTH IN QUALITY PRODUCTS AND QUALITY SERVICE.

PRODUCT WARRANTY

ALL MAGNETROL ELECTRONIC AND ULTRASONIC LEVEL CONTROLS ARE WARRANTED FREE OF DEFECTS IN MATERIALS AND WORKMANSHIP FOR ONE FULL YEAR FROM THE DATE OF ORIGINAL FACTORY SHIPMENT. IF RETURNED WITHIN THE WARRANTY PERIOD; AND, UPON FACTORY INSPECTION OF THE CONTROL, THE CAUSE OF THE CLAIM IS DETERMINED TO BE COVERED UNDER THE WARRANTY; THEN, MAGNETROL INTERNATIONAL WILL REPAIR OR REPLACE THE CONTROL AT NO COST TO THE PURCHASER (OR OWNER) OTHER THAN TRANSPORTATION. MAGNETROL SHALL NOT BE LIABLE FOR MISAPPLICATION, LABOR CLAIMS, DIRECT OR CONSEQUENTIAL DAMAGE OR EXPENSE ARISING FROM THE INSTALLATION OR USE OF THE EQUIPMENT. THERE ARE NO OTHER WARRANTIES EXPRESSED OR IMPLIED, EXCEPT, SPECIAL WRITTEN WARRANTIES COVERING SOME MAGNETROL PRODUCTS.

UNDER RESERVE OF MODIFICATIONS

BULLETIN N°: BE 48-600.0
EFFECTIVE: NOVEMBER 1994
SUPERSEDES: NEW



BELGIUM	Heikensstraat 6, 9240 Zele Tel. (052) 45.11.11	Fax (052) 45.09.93
DEUTSCHLAND	Schloßstraße 76, D-51429 Bergisch Gladbach-Bensberg Tel. (02204) 9536-0	Fax (02204) 9536-53
FRANCE	11, Rue A. Einstein, Espace Descartes, 77420 Champs-sur-Marne adresse postale: 77436 Marne-la-Vallée Cédex 2 Tel. (0) 164.68.58.28	Fax (0) 164.68.58.27
ITALIA	Via Arese 12, I-20159 Milano Tel. (02) 607.22.98 (R.A.)	Fax (02) 668.66.52
UNITED KINGDOM	Unit 1 Regent Business Centre Jubilee Road Burgess Hill West Sussex RH 15 9TL Tel. (01444) 871313	Fax (01444) 871317
INDIA	B4/115 Safdurjung Enclave, New Delhi 110 029 Tel. 91 (11) 6186211	Fax 91 (11) 6186418