



Magnetrol[®]

Echotel[®] Series 335/338
Compact Ultrasonic Transmitter

INSTALLATION
and
PROGRAMMING MANUAL

CONTENTS

1. INTRODUCTION.....	2
2. ORDER CODES	2
3. TECHNICAL DATA.....	3
3.1 Data of Echotel for liquids	3
4. INSTALLATION.....	4
4.1 Liquid Level Measurement	4
4.2 Open Channel Flow Measurement	5
4.3 Electrical Connection	5
5. PROGRAMMING.....	5
5.1 Touch-Magnet Programming (only for level transmitters for liquids).....	6
5.2 Programming of the Echotel by the 046-8108-001 Programming Module	8
5.2.1 The 046-8108-001 Programming Module	8
5.2.2 Programming with the 046-8108-001 Programming Module.....	9
5.2.3 Indications of the 046-8108-001 Programming Module and the LEDs	9
5.2.4 Current Output Scaling	10
5.2.5 QUICKSET	11
5.2.6 Full Parameter Access.....	12
6. PARAMETERS – DESCRIPTIONS AND PROGRAMMING.....	12
6.1 Measurement Configuration.....	12
6.2 Current Output.....	16
6.3 Relay Output	16
6.4 Measurement Optimisation	17
6.5 Volume Calculation	20
6.6 Volume Flow Measuring	20
6.7 32-Point Linearisation Curve.....	23
6.8 Informational Parameters	23
6.9 Additional Open Channel Flow Metering Features.....	24
6.10 Test Parameters	24
6.11 Simulation Mode	25
6.12 Access Lock	25
7. ERROR CODES	25
SOUND VELOCITIES IN DIFFERENT GASES	26

1. INTRODUCTION

Application

The Echotel compact ultrasonic level transmitters from MAGNETROL are an excellent tool for the level measurement of liquids.

Level measurement technology based on the non-contacting ultrasonic principle is especially suited for applications where, for any reason, no physical contact can be established to the surface of the material to be measured.

Such reasons may include corrosive attack by the process medium against the measuring device material (acids), possible contamination (sewage) or particles of the process medium adhering to the measuring device (adhesive materials).

Principle of Operation

The ultrasonic level metering technology is based on the principle of measuring the time required for the ultrasound pulses to make a round trip from the sensor to the level to be measured and back. The sensor emits an ultrasonic pulse train and receives the echoes reflected. The intelligent electronic device processes the received signal by selecting the echo reflected by the surface and calculates from the time of flight the distance between the sensor and the surface which constitutes the basis of all output signals of the Echotel

A **Total beam angle** of 5°-7° at -3 dB as is featured by most of Magnetrol's transducers ensuring a reliable measurement in narrow silos with uneven side walls as well as in process tanks with various protruding objects. Furthermore, as a result of the narrow beam angle - the emitted ultrasonic signals have an outstanding focusing - deep penetration through gases, vapour and foam is ensured.

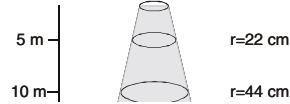

The Diameters corresponding to 5° beam angle.

Dead Band is a feature common to all ultrasonic level meters. It is specified as "Minimum measuring distance" in the Technical Data Table.

2. Identification Code

Basic Model Number:

- | | | | | |
|---|---|---|---|---|
| 3 | 3 | 5 | = | Integrally mounted transmitter with 50 kHz transducer and 8 meter range |
| 3 | 3 | 8 | = | Integrally mounted transmitter with 80 kHz transducer and 6 meter range |

Electronics Housing:

- | | | |
|---|---|-----------------------|
| P | = | Plastic (PBT) housing |
| A | = | Aluminum housing |

Input power:

- | | | |
|---|---|-------------------------------------|
| A | = | 85 to 265 V AC |
| D | = | 10.5 to 40 V DC,
10.5 to 28 V DC |

Signal Output:

- | | | |
|---|---|------------------------|
| 1 | = | 4 - 20 mA & SPDT relay |
|---|---|------------------------|

Accessories:

- | | | |
|---|---|---|
| 0 | = | No digital display/programming module |
| A | = | Digital display/programming module included |

Agency Approvals:

- | | | |
|---|---|-----------------------|
| G | = | General purpose IP 67 |
|---|---|-----------------------|

Mounting:

- | | | |
|---|---|--------|
| 5 | = | 2" NPT |
| B | = | 2" BSP |

Transducer Material:

- | | | |
|---|---|---------------|
| P | = | Polypropylene |
| K | = | Kynar |

3	3		-					-			
---	---	--	---	--	--	--	--	---	--	--	--

Order Codes for Accessories:

- 046 - 8108 - 001 : Local Indicator for Echotel 335/ 338 series
- 013 - 6165 - 001 : Magnetic Screwdriver - Calibration tool

3. TECHNICAL DATA

3.1 Data of Echotel for liquids

General data

Product name	Echotel 335/338 series
Product description	Compact type ultrasonic level transmitter
Housing material	Plastic: PBT fibre-glass reinforced, flame-retardant (DuPont®) Aluminium: Powder paint coated
Ambient temperature	-30°C ... +60°C with 375 - 0SAP -100 -25°C ... +60°C If necessary, protect the device from over-heating by direct sunshine!
Pressure (Absolute.)	0.3 ... 3 bar (0,03 ... 0,3MPa)
Seals	PP transducer: EPDM All other transducer versions: FKM (Viton)
Mechanical protection	Sensor: IP68 (submersible) Housing: IP67 (NEMA 6)
Power supply / Consumption	High voltage version: 85 ... 255 V AC / 6 VA Low voltage version: 10,5 ... 40 VDC / 3,6 W, 10,5 ... 28 V AC / 4 VA
Accuracy*	± (0.2% of the measured distance plus 0.05% of the range)
Resolution	< 2 m: 1 mm, 2...5 m: 2 mm, 5...8 m: 5 mm
Outputs	Analogue: 4/20 mA, 600 Ohm, galvanically isolated, secondary lightning protection Contact: SPDT (NO/NC); 250 V AC, 3 A HART (optional) Display (375 - 0SAP -100): 6 digits, icons and bargraph, Custom LCD
Electrical connections	2 x Pg16 and 2 x 1/2" NPT Wire cross section: 0,5 ... 2,5 mm ²
Electrical protection	Class I.

* Under optimal circumstances of reflection and stabilised transducer temperature.

Special data of Echotel for liquids with PP and PVDF transducers

Type	Echotel® 338	Echotel® 335
Transducer material	PP or PVDF	PP or PVDF
Maximum measuring distance * [m / ft]	6 / 20	8 / 26
Min. measuring distance* (Dead band) [m / ft]	0,25 / 0,82	0,35 / 1,2
Total beam angle (-3 dB)	5°	7°
Measuring frequency	80 kHz	50 kHz
Process connection	2" thread	2" thread

* (taken from the transducer face)

375-0 375 - 0SAP -100 Programming Module

Field indication	6 digits, icons and bargraph, Custom LCD
Ambient temperature	-25°C ... +60°C
Housing material	PBT fibre-glass reinforced plastic, flame-retardant (DuPont®)

Dimensions of Echotel 338/335

Echotel 338: PP, PVDF, PTFE	Echotel 335: PP, PVDF, PTFE

4. INSTALLATION

4.1 Liquid Level Measurement

POSITION

The optimal position of the Echotel is between 1/2 radius and 2/3 diameter of the (cylindrical) tank / silo. (Take also sonic cone on page 1 into consideration.)

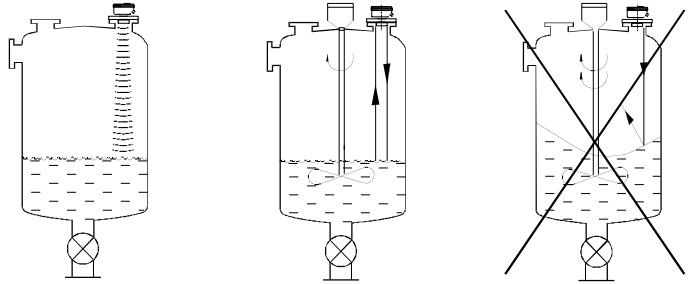

PARALLELITY

The sensor face has to be parallel to the surface of the liquid within $\pm 2-3^\circ$.

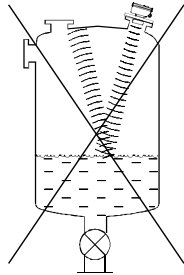

TEMPERATURE

Make sure that the transmitter will be protected against overheating by direct sunshine.

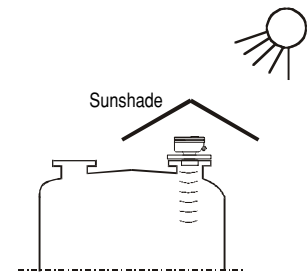

OBSTACLES

Make sure that no in-flow path or objects (e.g. cooling pipes, ladders, bracing members, thermometers, etc) or no tank wall of the ragged surface protrude into the sensing cone of the ultrasonic beam.

Although up to two fix objects in the tank / silo that disturb the measurement can be blocked out by the appropriate programming of the Echotel

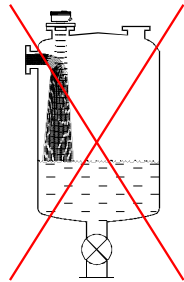

FOAM

Foaming of the liquid surface may render ultrasonic level measuring impossible. If possible, a location should be found, where foaming is the smallest (the device should be located as far as possible from liquid in flow) or a stilling pipe or well should be used.

FUME/VAPOUR

In case of closed tanks containing chemicals or other liquids creating fume/gases above the liquid surface especially for outdoor tanks exposed to the sun, a strong reduction of the nominal measuring range of the ultrasonic device is to be considered during device selection.

WIND

An intensive moving of the air (gas) in the vicinity of the ultrasonic cone is to be avoided. A strong draft of wind may "blow away" the ultrasound.

STAND-OFF PIPE

The structure of the stand off pipe should be rigid, the inner rim where the ultrasonic beam leaves the pipe should be rounded.

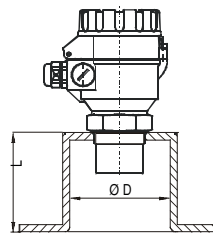

L in mm	D min (in mm)	
	Echotel 338	Echotel 335
150	60	60
200	60	75
250	65	90
300	75	105
350	85	120

4.2 Open Channel Flow Measurement

- For ultimate accuracy, install the sensor as close as possible above the expected maximum water level (see minimum measuring range).
- Install the device upstream in a place defined by the characteristics of overflow and metering channel along the longitudinal axis of the flume or weir.
- From the point of view of measurement accuracy the length of the channel sections preceding and following the measuring flume and their method of joining to the measuring channel section are of critical importance.
- Despite of the most careful installation, the accuracy of flow metering will be lower than that of specified for distance measurement. It will be determined by the features of the flume or weir applied.

4.3 Electrical Connection

- Screw out the hexagonal countersunk screw at the side of the model. Lift the tilt cover to access the screw terminal.
- There is a basic requirement for separating the 4...20 mA signal cable and 230 V AC supply (or output relay) cable by shielding.
- For grounding the unit, either use the grounding screw terminal on the outside of the housing; or use a three wire mains cable, connecting the third wire to the internal grounding screw terminal.
- Three-wire installation is also possible for the 24 V DC versions by connecting the terminals 1 and 6. In this case the galvanic isolation is not provided.
- The unit may be damaged by electrostatic discharge (EDS), via terminal, thus apply the precautions commonly used to avoid electrostatic discharge.

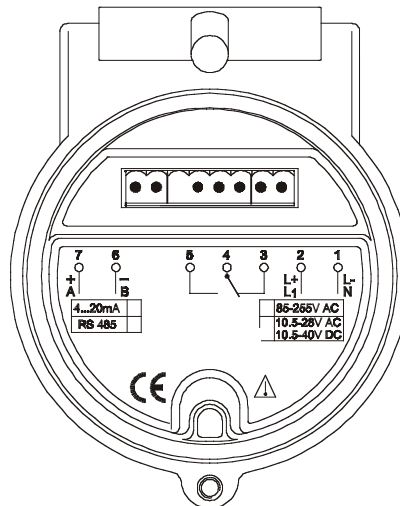

5. PROGRAMMING

The Echotel will be delivered with the following Factory Default:

- ⇒ Current output, display and bargraph: LEVEL
- ⇒ 4 mA: assigned to the minimum level 0%
- ⇒ 20 mA: assigned to the maximum level 100%
- ⇒ Error indication by the current output: hold last value
- ⇒ Damping: 60 sec for liquids, 300 sec for solids

The device can be programmed in two ways:

- **Touch-Magnet Programming** by the supplied magnetic screwdriver (with level transmitters for liquids only), see 5.1. Assignment of the levels to the 4 and 20 mA current output, relay switch differential (both with an accuracy of ± 20 mm) error indication by the analogue signal and damping can be set.
- With the **046-8108-001 programming module**, see 5.2. All features of the device can be set, such as measurement configuration and optimization, relay programming, 32-point linearisation, dimensions for 6 tanks with different shape and for 21 different open channels (flume or weir) etc.

Some Devices are already equipped with the 046-8108-001 (see Identification code – page 3).

The Echotel is fully operational without the 046-8108-001. The 046-8108-001 is only needed for programming and/or displaying measurement values.

If the transmitter is left in Programming Mode by mistake, it will automatically return to Measurement Mode after 30 minutes and will operate with the parameters entered during the last completed programming.

5.1 Touch-Magnet Programming

The following can be programmed: with the supplied magnetic calibration tool – screwdriver PN°013-6165-001:

- Assignment of the 4 mA analogue output to a required e.g. min. level / max. distance
- Assignment of the 20 mA analogue output to a required e.g. max. level / min. distance
- Error indication by the current output (Hold, 3.6 mA, 22 mA) see Chapter 6.2.(P12)
- Relay switching different
- Damping (10, 30 and 60 sec)
- Reset to the factory default

Note: Current output can also be assigned in inverted mode:

4 mA = 100% (Full), 20 mA = 0% (Empty)

Programming is only possible if the Echotel receives valid echo i.e. "ECHO" LED is lit!

and transmitter is in LEV measuring mode (factory default).

The accuracy of the setting with this programming method is limited to ± 20 mm. Thus the relay switching difference between "On" and "OFF" must be greater than 20 mm.

For programming: put magnetic screwdriver in accordance with the place to place A or B and check the LEDs for their status:

● = LED is on, ○ = LED is off, ●○ = LED is blinking, ○● = LEDs are blinking alternatively
Make sure that after programming completed all other magnetic influences will be avoided.

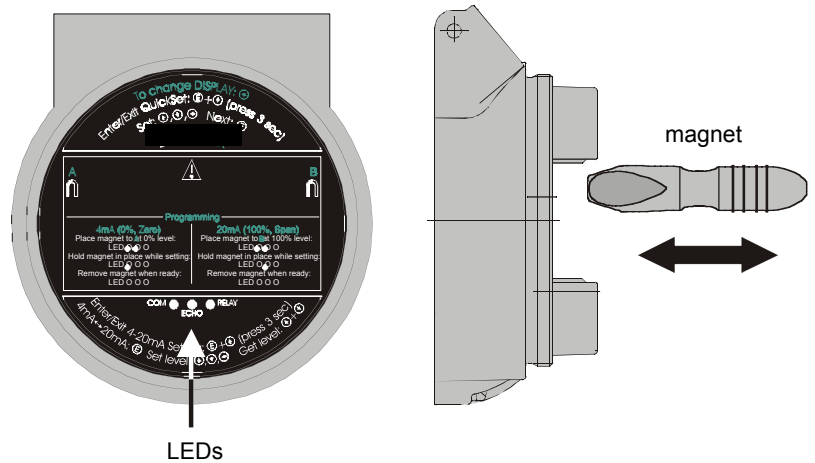

Minimum level, 0%, empty tank (assignment to 4 mA,)

Place the Echotel at a distance to the target corresponding to the required maximum distance/minimum level.

Action	LED indication	
1) Check valid echo	○●○ = Valid echo received, transmitter programmable	<p>Use level in tank or a fix target e.g. the wall</p>
2) Place magnet to the symbol "A" and	●●○ = Transmitter in programming mode	
3) Hold magnet in place	●○○ = Distance assigned to 4 mA	
4) Remove magnet when all LEDs are off	○○○ = Programming completed	

Maximum level 100%, full tank (assignment to 20 mA)

Place the Echotel in a distance to the target corresponding to the required minimum distance/ maximum level.

Action	LED indication	
1) Check valid echo	○●○ = Valid echo received, transmitter programmable	<p>Use level in tank or a fix target e.g. the wall</p>
2) Place magnet to the symbol "B" and	●●○ = Transmitter in programming mode	
3) Hold magnet in place	○●○ = Distance assigned to 20 mA	
4) Remove magnet when all LEDs are off	○○○ = Programming completed	

Programming relay switch-on point (the level where relay becomes energised)

Place the Echotel at a distance to the target corresponding to the required switch-on point. (Do not forget to check valid Echo!)

Action	LED indication	
1) Place magnet to symbol "A"	●●○ = Programming mode	<p>Use level in tank or a fix target, i.e. the wall</p>
2) Place magnet to symbol "B" and	○●○ = Programming in progress	
3) Hold magnet to symbol "B"	●●○ = Programming in Progress	
4) Place magnet to symbol "A"	●○○ = Programming in Progress	
5) Remove magnet when all LEDs are off	○○○ = End of Programming	

Programming relay switch-off point (the level where relay becomes de-energised)

Place the Echotel at a distance to the target corresponding to the required switch-off point. (Do not forget to check valid Echo!)

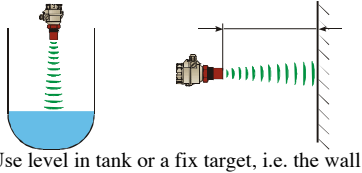
Action	LED indication	
1) Place magnet to symbol "A"	●●○ = Programming mode	
2) Place magnet to symbol "B" and	○●○ = Programming in progress	
3) Hold magnet to symbol "B"	●●○ = Programming in progress	
4) Keep holding magnet to symbol "B"	○●○ = Programming in progress	
5) Remove magnet when all LEDs are off	○○○ = End of Programming	

Please note that the smallest switch-differential achievable with magnet programming is 20 mm.

"Error indication" by the current output (Check valid echo as above)

Action	LED indication
1) Place magnet to the symbol "A"	●●○ = Transmitter in programming mode
2) Place magnet to the symbol "B" repeatedly to select the required error indication mode	●○○ = Hold last value ○●○ = 3.6 mA ●●○ = 22 mA
3) Place magnet to the symbol "A"	○○○ = Programming completed

"Damping" (Check valid echo as above)

Action	LED indication
1) Place magnet to the symbol "B"	●●○ = Transmitter in programming mode
2) Place magnet to the symbol "A" repeatedly to select the required damping	●○○ = 10 sec ○●○ = 30 sec ●●○ = 60 sec
3) Place magnet to the symbol "B"	○○○ = Programming completed

Reset (to factory default)

Action	LED indication
1) Place magnet to the symbol "B"	●●○ = Programming mode
2) Place magnet to the symbol "A and	●○○ = Reset in progress
3) Hold magnet to the symbol "A"	●●○ = Reset in progress
4) Remove magnet when all LEDs are off	○○○ = End of programming

Error indications during programming (by LEDs)

Action	LED status = error indicated	Correction
1) Attempted programming	●●○ = blinking twice = No Echo	Find valid echo
2) Attempted programming	●●○ = blinking three times = access denied (access code active)	With use of 375 - OSAP -100 see Chapter 5.2 (P99)
3) Attempted programming	●●○ = blinking four times = Echotel not in LEV meas. mode	With use of 375 - OSAP -100 see Chapter 5.2 (P01)
4) Programming of the relay	●●○ = blinking alternately = switch-differential too small	Set switch-differential greater than 20 mm

5.2 Programming of the Echotel by the 046-8108-001 Programming Module

The 046-8108-001 supports 3 separately accessible programming modes representing 3-layers of programming complexity, depending on user choice.

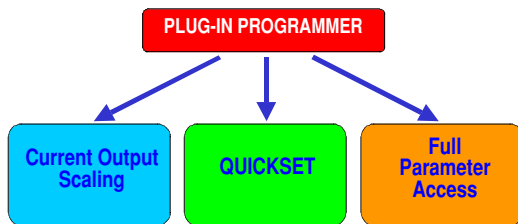

Current Output Scaling (5.2.4)

Recommended as a simple and fast way to modify the scaling of the current output.

QUICKSET (5.2.5)

Recommended as a simple and fast way to set up the Echotel by 8 basic parameters

This menu driven programming mode supports the following basic settings:

- Engineering unit for the display (Metric or US)
- Maximum measuring distance
- Assignment of min level to 4mA
- Assignment of max level to 20mA
- Error indication by the current output
- Damping time
- Assignment of level to energising of the relay
- Assignment of level to de-energising of the relay

Full Parameter Access (5.2.6)

All features of the Echotel can be accessed by parameter addresses:

Example:

- Measurement configuration
- Outputs
- Measurement optimisation
- 6 pre-programmed tank shapes for volume calculation
- 32-point linearisation table
- Open channel flow metering functions

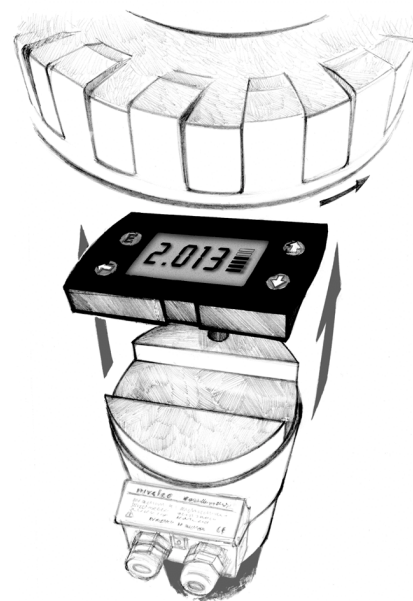

5.2.1 The 046-8108-001 Programming Module

The plug in programming and display module is used for programming but also for display even in case of Touch-Magnetic Programming

The Display and keys

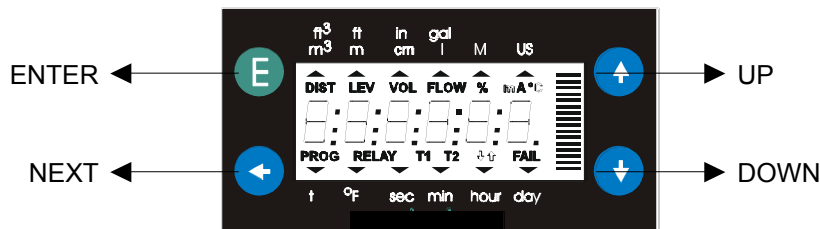

Symbols used on the LCD:

- **DIST** – Distance (measuring) mode
- **LEV** – Level (measuring) mode
- **VOL** – Volume (measuring) mode
- **FLOW** – Open channel (flow metering) mode
- **PROG** - Programming mode (device under programming)
- **RELAY** – Relay
- **T1** - TOT1 volume flow totaliser (resettable aggregate)
- **T2** - TOT2 volume flow totaliser (aggregate)
- **FAIL** - Measurement / device error
- \updownarrow - Level changing direction
- Bargraph assigned to the current output or echo strength

Symbols used on the frame:

- **M** – Metric system
- **US** – US calculation system

5.2.2 Programming with the 046-8108-001 Programming Module

Programming will be performed by pressing one or two keys (simultaneously).

Single key pressing

- Ⓔ Press key ENTER - to save parameter address and go to parameter value to return from parameter value to parameter address
- ⬅ Press NEXT to move the blinking of the digit to the left
- ⬆ Press UP to increase value of the blinking digit
- ⬇ Press DOWN to decrease value of the blinking digit

Double key pressing

(Short overview, for details see in 5.2.4, 5.2.5 and 5.2.6)

Press the two keys simultaneously for desired programming step.

Enter into or quit programming modes
blinking

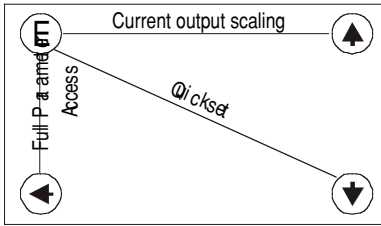

Basic steps while parameter address is blinking

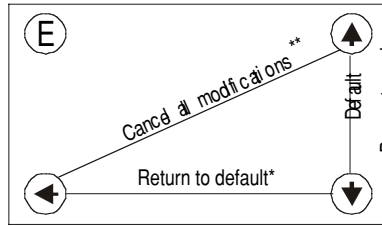

* LOAD will be displayed
** CANCEL will be displayed

Basic steps while parameter value is

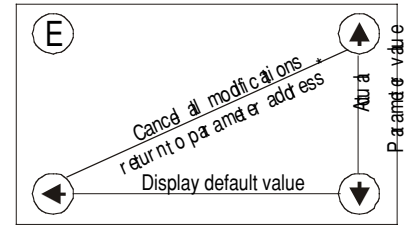

* cancellation immediately active

Notes:

If the parameter value is not accessible i.e. the parameter address keeps blinking after pressing ENTER (Ⓔ),

- the parameter is either a read-out type, or
- the secret code prevents the modification (see P99).

If the modification of the parameter value is not accepted i.e. the parameter value keeps blinking after pressing ENTER (Ⓔ),

- the modified value is either out of the range, or
- the code entered is not valid for this parameter

5.2.3 Indications of the 046-8108-001 Programming Module and the LEDs

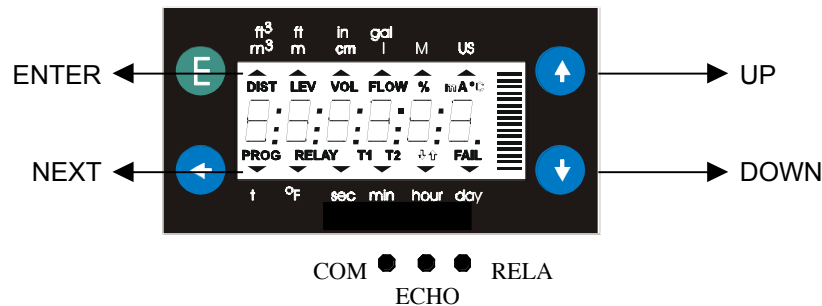

Field indication

Depending on the measuring mode (see P01 in Chapter 5.2.3) the following values can be displayed (relevant symbol is lit):

- Distance
- Level
- Volume
- Flow
- TOT1 and TOT2
- Error code (if "FAIL" is blinking)

To scroll through the displays above press NEXT (⬅) repeatedly.

To display transducer temperature, press UP (⬆):

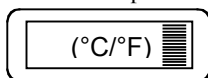

To display current output value, press DOWN (⬇):

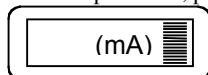

LED indication

ECHO - LED

LED is lit as long as the device receives a valid echo signal

RELAY - LED

LED is lit when relay is energized

COM - LED

LED is lit during communication (Remote control)

5.2.4 Current Output Scaling

This programming mode is the simple and fast way to modify the scaling of the current output.

For changing all parameters other than those assigned to 4 and 20 mA use either the QUICKSET (5.2.2), or the Full Parameter Access (5.2.3).

Current Output Scaling mode is useful for re-scaling i.e. for modifying of the minimum and maximum level assigned to the output signals 4 and 20 mA, if other than the factory default.

Current Output Scaling is aided by 2 screens for setting.

The instructions for this programming can also be found below the screw cover on the front panel of the Echotel.

Note: For this programming the Echotel has to be in level measurement mode. See chapter 6.1 (P01)

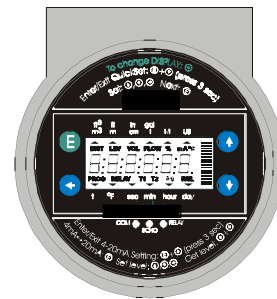

Keys	Function
ENTER (E) + UP (▲) (press for 3 seconds)	Enter or exit Current Output Scaling programming mode
UP (▲) / DOWN (▼)	Increase/decrease blinking digit or scroll up/down
NEXT (◀)	Move left with the blinking digit
UP (▲) + DOWN (▼)	"GET LEVEL" - display actual level value measured by the Echotel
ENTER (E)	Save actual value on the screen and move to the next screen
NEXT (◀) + UP (▲)	Quit Current Output Scaling without saving the modifications
NEXT (◀) + DOWN (▼)	Display Factory Default of the relevant screen

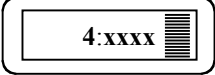
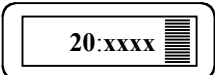
Screens	Actions
 <p>4 represents the output signal x = level value to be assigned</p>	<p>4 mA xxxx: – level value assigned to 4 mA current output Manual: set required value (by UP (▲) / DOWN (▼) / NEXT (◀) keys) and save it (by the key ENTER (E)) Automatic: use the “GET LEVEL” function (UP (▲) + DOWN (▼)) to obtain actual measured value with level in tank or a fix target, e.g. wall. (“GET LEVEL” functions only if ECHO LED is lit) and save it as above. DEFAULT: 0 m (0%, Empty tank)</p>
 <p>20 represents the output signal x = level value to be assigned</p>	<p>20 mA xxxx: – Level value assigned to 20 mA current output Manual: set required value (by UP (▲) / DOWN (▼) / NEXT (◀) keys) and save it (by the key ENTER (E)) Automatic: use the “GET LEVEL” function (UP (▲) + DOWN (▼)) to obtain actual measured value with level in tank or a fix target, e.g. wall. (“GET LEVEL” functions only if ECHO LED is lit) and save it as above. DEFAULT: max. level = max. measuring distance - dead band (100%, Full tank) See chapter 5.1 (P04, P05)</p>

5.2.5 QUICKSET

Recommended as a simple and fast way to start up Echotel.

QUICKSET programming is aided by 8 screens to set the 8 basic parameters of the device if the required application is uncomplicated level metering, recommended for liquids only.

The instructions of this programming mode are also to be found, below the screw cover, on the front panel of the Echotel.

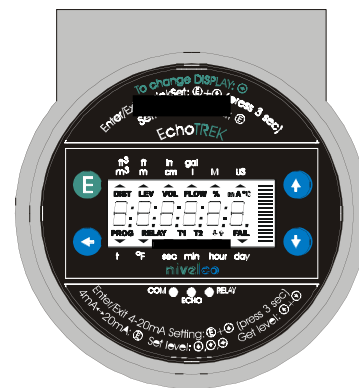

The DEFAULT of the Current output, Display and Bargraph is LEVEL.

This can be modified only in the Full Parameter Access mode see 5.1 (P01).

Keys	Function
ENTER (E) + DOWN (D) (press for 3 seconds)	Enter or exit QUICKSET programming mode
UP (U) / DOWN (D)	Increase/decrease blinking digit or scroll up/down
NEXT (N)	Move left with the blinking digit
UP (U) + DOWN (D)	"GET LEVEL" - display actual level measured by Echotel
ENTER (E)	Save value on the screen and move to the next screen
NEXT (N) + UP (U)	Quit QUICKSET programming mode without saving the modifications
NEXT (N) + DOWN (D)	Display Factory Default of the relevant screen

See next page for details.

Screens	Actions
	APplication xx= select "EU" (European) for metric or "US" for US engineering units (Use UP (U) / DOWN (D) keys) yy= indicating "Li" for liquids or "So" for solids level measurement (can not be changed). DEFAULT: EU
	H = xxxx maximum measuring distance – Distance between transducer face and tank/silo bottom Manual: set value (Use UP (U) / DOWN (D) / NEXT (N) keys) and save it (by ENTER (E)) Automatic: use the "GET LEVEL" function (UP (U) + DOWN (D)) to obtain actual measured value with level in tank or a fix target, i.e. wall. ("GET LEVEL" functions only if ECHO LED is lit) and save it as above. DEFAULT: maximum measuring distance [m], see Technical Data Table
	4 mA xxxx – level value assigned to 4 mA current output Manual: set level value (by UP (U) / DOWN (D) / NEXT (N) keys) and save it (by ENTER (E)) Automatic: use the "GET LEVEL" function (UP (U) + DOWN (D)) to display the actual measured value with level in tank or a fix target, i.e. wall. ("GET LEVEL" functions only if ECHO LED is lit) and save it as above. DEFAULT: 0 m (0%, Empty tank)
	20 mA xxxx – level value assigned to 20 mA current output Manual: set level value (Use UP (U) / DOWN (D) / NEXT (N) keys) and save it (by ENTER (E)) Automatic: use the "GET LEVEL" function (UP (U) + DOWN (D)) to obtain actual measured value with level in tank or a fix target, i.e. wall. ("GET LEVEL" functions only if ECHO LED is lit) and save it as above. DEFAULT: max. level = max. measuring distance – dead band [m] (100%, Full tank) (See Technical Data Table)
	Error indication by the current output – select "Hold", "3.6" mA or "22" mA (by UP (U) / DOWN (D) key) and save it as above. DEFAULT: hold last value
	damping time: select required damping time (by UP (U) / DOWN (D) key) and save it as above. DEFAULT: 60 sec for liquids, 300 sec for solids
	relay Energised xxxx: level of the relay energised state If the value exceeds this programmed value the relay will be energised
	relay de-energised xxxx: level of the relay de-energised state If the value sinks below this programmed value the relay will be deenergised

Note: Current output can also be programmed for inverted operation: 4 mA= 100% (Full), 20 mA= 0% (Empty)

5.2.6 Full Parameter Access

To access all features provided by the Echotel.

Description of all parameters can be found under the chapter "Parameter" (Chapter 6.).

Keys	Function
ENTER (E) + NEXT (N) (press for 3 seconds)	Enter or exit Full Parameter Access programming mode.

In this programming mode, the display will indicate:

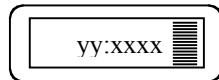

yy is the Parameter Address
xxxx is the Parameter Value

Note: Measuring is going on during programming in accordance with the old parameter set. New parameter set will be valid after returning to measurement from programming mode.

Steps and indications of the Full Parameter Access programming mode

pressing Keys	while Parameter Address is blinking	while Parameter Value is blinking
ENTER (E)	Go to the Parameter Value	Save the modification of the Parameter Value and return to the Parameter Address
NEXT (N) + UP (U)	Cancel all modifications of the actual programming phase. Pressing for 3 secs is required while CANCEL will be displayed for warning	Neglect the modification of the Parameter Value. and return to the Parameter Address without saving the modifications
NEXT (N) + DOWN (D)	Reset entire device to Factory Default. Since this action will reset all parameters, "LOAD" will appear on the display: - to confirm, press ENTER - to escape, press any other key - Exception: clearing TOT 1 (See at P77)	Display default of the Parameter Values (it can be saved by pressing ENTER (E))
NEXT (N)	Move blinking of the digit to the left	
UP (U) / DOWN (D)	Modify the blinking digit (increase, decrease) or scroll up/down	

6. PARAMETERS – DESCRIPTIONS AND PROGRAMMING

6.1 Measurement Configuration

P00: - cba Application/Engineering Units

Programming of this parameter will result in loading the factory default with the corresponding engineering units.

a	Operating (measurement) mode	Display indication
0	Liquid level measurement	"Li"
1	Free flowing solids level measurement	"So"

b	Engineering units (according to "c")	
	Metric	ft
0	m	inch
1	cm	inch

c	Calculation system
0	Metric
1	US

Attention: mind the sequence!
Coming to this parameter the right value "a" will be blinking first.

FACTORY DEFAULT: 000

P01: - ba Measurement Mode

Display, current output and the switching points of the relays will be interpreted in the engineering units of the (measured or calculated) process value corresponding to the programmed measurement mode. On the other hand the higher the “a” of the programmed parameter value the more (measured or calculated) process values can be displayed on the screen. (e.g. if P01=b0 only the Distance, if P01=b5 the Distance the Level, the Volume and the Flow can be displayed. Exception if P01=b2 or b4.)

a	Measurement Mode	Display symbol
0	Distance	DIST
1	Level	LEV
2	Level in percentage	LEV %
3	Volume	VOL
4	Volume in percentage	VOL %
5	Flow	FLOW

**Attention: mind the sequence!
Coming to this parameter the right value “a” will be blinking first.**

b	Bargraph indication
0	Echo strength
1	Current output

FACTORY DEFAULT: 11

P02: - cba Calculation units

a	Temperature
0	°C
1	°F

**Attention: mind the sequence!
Coming to this parameter the right value “a” will be blinking first.**

This table is interpreted according to P00(c), P01(a) and P02(c) and is irrelevant in case of percentage measurement (P01(a)= 2 or 4)

b	Volume		Weight (set also P32)		Volume flow	
	Metric	US	Metric	US	Metric	US
0	m ³	ft ³	-	lb (pound)	m ³ /time	ft ³ /time
1	liter	gallons	tons	tons	liter/time	gallons/time

c	Time
0	Sec
1	Min
2	Hour
3	Day

FACTORY DEFAULT: 000

P03: - - - a Values Displayed-Rounding

It is important to keep in mind that the instrument is measuring distance as basic quantity.

Measured distance	Resolution
X _{min} – 2m	1mm
2m – 5m	2mm
5m – 10m	5mm
over 10m	10mm

The resolution depending on the distance can be considered as a kind of rounding that will be contained in all further value (of level, volume or volume flow) calculated. Therefore if programmed for DIST or LEV measurement the setting of P03 is irrelevant.

Displayed VOL or FLOW

Displayed value	Displayed form
0.000 – 9.999	x.xxx
10.000 – 99.999	xx.xx
100.000 – 999.999	xxx.x
1000.000 – 9999.999	xxxx.
10000.000 – 99999.999	xxxxx.
1 million – 9.99999*10 ⁹	x.xxxx : e (exponential form)
over 1*10 ¹⁰	(overflow) Err4

Obviously the decimal position will be shifted with increasing value displayed. (See table at the left).

Values over one million will be displayed in exponential format whereas the value (e) represents the exponent. Over the value of 1x10¹⁰ Err4 (overflow) will be displayed.

Rounding

Parameter value “a”	Steps in the displayed value
0	1 no rounding
1	2
2	5
3	10
4	20
5	50

A couple of millimetres of fluctuation of the basic DIST value (e.g. due to waves) will be enlarged by the mathematical operations. This enlarged fluctuation in displaying VOL or FLOW can (if disturbing) be avoided by rounding to be set in P03. Rounding value 2, 5, 10 etc represents the steps by which the calculated value will be changed in its (one or two) last digit(s).

Examples:

P03=1 steps by 2: 1,000; 1,002; 1,004

P03=5 steps by 50: 1,000; 1,050; 1,100 or 10,00; 10,05(0); 10,10(0); 10,15(0)

(the 0 from the steps 50, 100, 150 etc will not be displayed)

FACTORY DEFAULT: 0

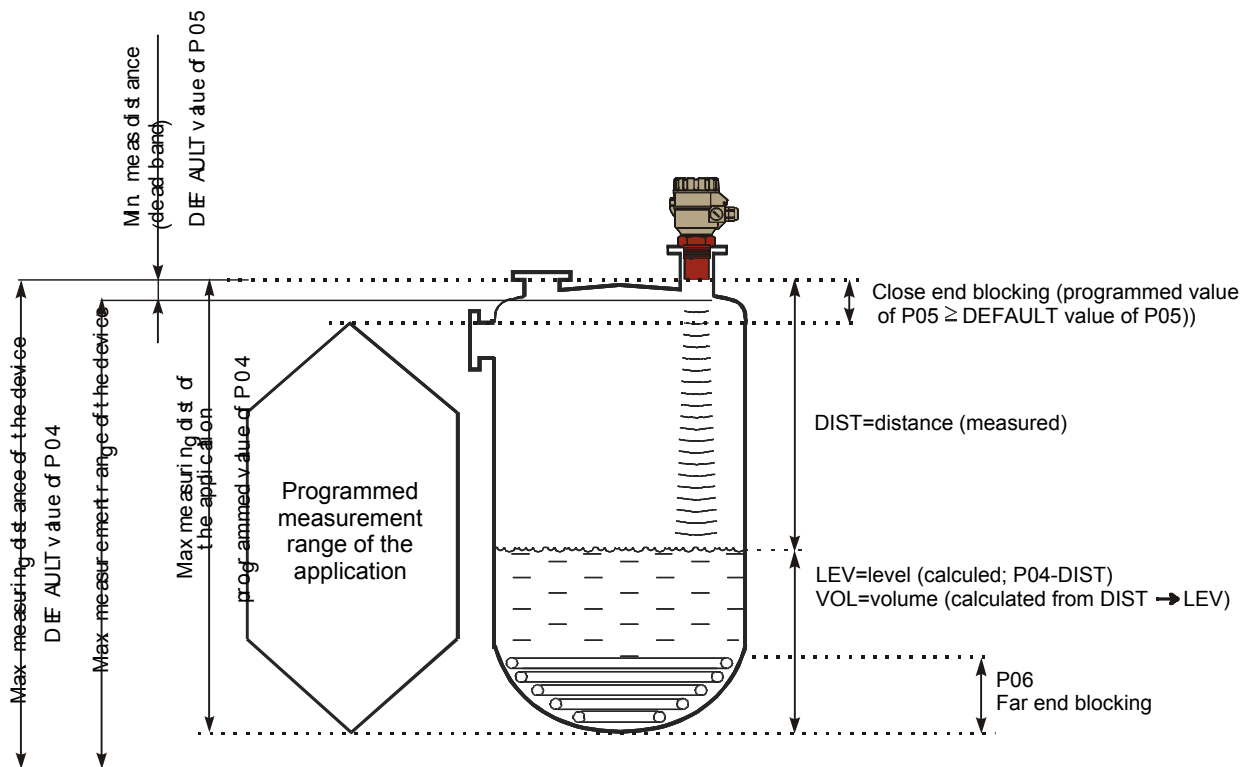

Basic conception and elements of the ultrasonic measurement

P04: Maximum measuring distance

The maximum measuring distance is the only one parameter that has to be programmed for each application other than distance measurement mode. The DEFAULT value of P04 (see table below) can also be displayed by double key pressing NEXT (⬅) + DOWN (⬇).

Echotel	Maximum measuring distance
Level transmitters for liquids	PP or PVDF (m/ft)
Echotel 338	6 / 20
Echotel 335	8 / 26

Keep in mind that

LEVEL (as the result of the measurement) = **P04** (programmed) – **DISTANCE** (measured by the device)

Since the accuracy of level (and all further calculated) value depends on the accuracy of the max measuring distance of the application which is the distance between the sensor face and the tank / silo bottom.

To obtain the best accuracy for a liquid level measurement, measure this distance in the empty tank with the Echotel by using

the “GET LEVEL” function (press UP (⬆) and DOWN (⬇) keys simultaneously) provided the bottom is flat. Enter the actual measured value displayed as P04.

Values of the maximum measuring distance will be in accordance with the table below.

Engineering unit	Display format
m	X.XXX or XX.XX
cm	XXX.X
ft	XX.XX or XXX.X
inch	XXX.X

P05: Minimum measuring distance (Close-end blocking)

The Echotel will not accept any echo within the blocking distance set here.

Automatic Close-end-blocking (Automatic Dead Band control)

By using the factory default value, the unit will automatically set the smallest possible close-end-blocking distance i.e. the dead band.

Manual close-end-blocking

Manual close-end-blocking would be used for example to block out the echo originating from the bottom rim of a stand-off pipe or from any object protruding into the ultrasonic cone near to the transmitter.

By entering a value, higher than the factory default, the minimum measuring range will be extended and fixed to the specified value.

To display factory default of the minimum measuring distance press NEXT (⊕) + DOWN (⊖).

Echotel Level transmitters for liquids	Factory default of the minimum measuring distance (dead band)
	with PP or PVDF transducers (m/ft)
Echotel 338	0,25 / 0,82
Echotel 335	0,35 / 1,2

FACTORY DEFAULT: automatic dead band control

P06: Far-end blocking

A). Level measurement

Far end blocking is used to neglect incorrect level/volume readings and output actions below a pre-set level. In the far-end of the measuring range, for example tanks with heaters or other interfering objects (sludge, cone of silo etc.) may cause faulty readings.

If the level of the medium sinks below the blocked out range:

- "Sub 0" will be indicated for the level and volume
- Distance value is not interpretable
- Current output will hold value corresponding to the far end blocking level

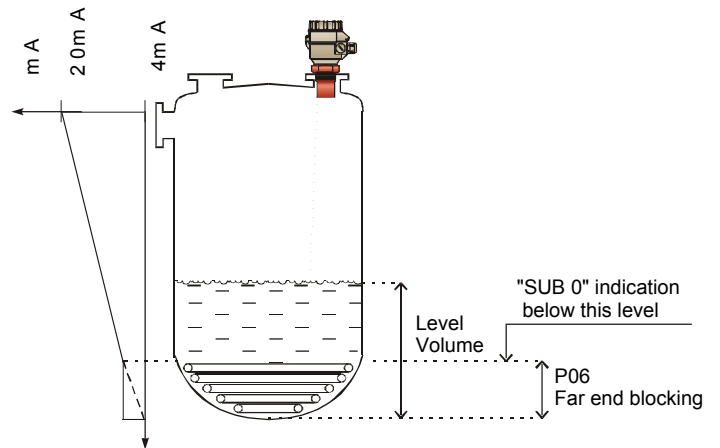

If the medium level is above the blocked out range:

The calculation of level and volume will be based on the programmed tank dimensions, therefore the measured or calculated process values will not be influenced in any way, by the far end blocking value.

B). Open channel flow metering

Far end blocking will be used to neglect incorrect volume flow readings and output actions below a pre-set level, where accurate volume flow calculation is not possible any more.

If the liquid level in the flume/weir falls below the blocked out range:

The Echotel will act as follows:

- Indicate "No Flow" on the Display
- Hold last valid data on the current output.

If the level in the flume/weir is above the blocked out range:

The calculation of volume flow will be based on the programmed flume/weir data, therefore the measurement values will not be influenced in any way, by the far end blocking value.

FACTORY DEFAULT: 0

6.2 Current Output

P10: Value (of distance, level, volume or flow) assigned to 4 mA current output

P11: Value (of distance, level, volume or flow) assigned to 20 mA current output

Values are interpreted according to **P01(a)**. Please note that in case of programming for (LEV or VOL) % measurement the min and max value has to be entered in the relevant engineering units of LEV (m, ft) or VOL (m³, ft³).

Assignment can be made so that the proportion between the change of the (measured or calculated) process value and the change of the current output be either direct or inverse. E.g. lev 1m assigned to 4mA and lev 10m assigned to 20mA represents direct proportion and lev 1m assigned to 20mA and lev 10 m assigned to 4mA represents the inverse proportion.

FACTORY DEFAULT:

P10 0 level (max distance)

P11 max level (min distance)

P12: - - - a Error indication by the current output

In case of error the Echotel will provide one of the current outputs below. (For errors and their indications see Chapter 7).

a	Error indication (according to NAMUR)
0	Hold last value
1	3.6 mA
2	22 mA

FACTORY DEFAULT: 0

6.3 Relay Output

P13: - - - a Relay function

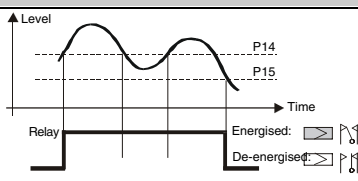
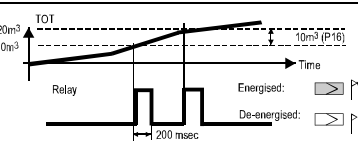
a	Relay function	Also set:
0	<p>DIFFERENTIAL LEVEL CONTROL (Hysteresis control)</p> <p>Relay is energised if the measured or calculated value exceeds the value set in P14</p> <p>Relay is de-energised if the measured or calculated value descends under the value set in P15</p>	 <p>P14, P15</p> <p>There is a need to set (in level min 20mm) hysteresis between P14 and P15</p>
1	Relay is energised in case of Echo Loss	-
2	Relay is de-energised in case of Echo Loss	-
3	<p>COUNTER</p> <p>Used for open channel flow metering.</p> <p>A 140 msec pulse is generated every 1, 10, 100, 1.000 or 10.000 m³ according to P16.</p>	 <p>P16= 0: 1m³ P16= 1: 10 m³ P16= 2: 100 m³ P16= 3: 1.000 m³ P16= 4: 10.000 m³</p>

FACTORY DEFAULT: 2

P14: ... Relay parameter – Setpoint value FACTORY DEFAULT: 0

P15: ... Relay parameter – Setpoint value FACTORY DEFAULT: 0

P16: ... Relay parameter – Pulse rate FACTORY DEFAULT: 0

6.4 Measurement Optimisation

P20: --- a Damping

Use this parameter to reduce unwanted fluctuation of the display and output.

a	Damping time (seconds)	Echotel 335 / 338	
		None/moderate fume or waves	Heavy/dense fume or turbulent waves
0	no filter	Recommended for testing only	
1	3	applicable	not recommended
2	6	recommended	applicable
3	10	recommended	recommended
4	30	recommended	recommended
5	60	recommended	recommended
6	100	applicable	applicable
7	300	applicable	applicable
8	600	not applicable	not applicable
9	1000	not applicable	not applicable

FACTORY DEFAULT: for Liquids: 60 sec

P22: --- a Dome top tank compensation

To reduce disturbing effect of possible multiple echos.

a	Compensation	Applied
0	OFF	In case the Echotel is mounted not in the centre of the top and the top is flat.
1	ON	In case the Echotel is mounted in the centre of a tank with dome-shaped top

FACTORY DEFAULT: 0

P23: --- a Angle of repose (repose formation) only for free flowing solids applications

This parameter provides information for the QUEST+ software for optimising the echo-search pattern.

a	Estimated angle of repose
0	No angle of repose (default)
1	Below 15° (α)
2	Over 15° (α)

The optimal setting of this parameter can be done with the help of checking the echo strength in the read out parameter **P72** indicating the echo amplitude in dB. The ideal setting of **P23** is at which the parameter value in **P72** becomes the best (nearest "0").

- 1). Set **P23** for **a= 1**, confirm it with [E] and switch to Measurement Mode then return to Programming Mode.
- 2). Observe the change of echo amplitude in **P72** and record an average value.
- 3). Perform the above with the **P23 = 2** setting.
- 4). Finally set **P23** with the value of (**a**) at which the amplitude value in **P72** is nearest to 0.

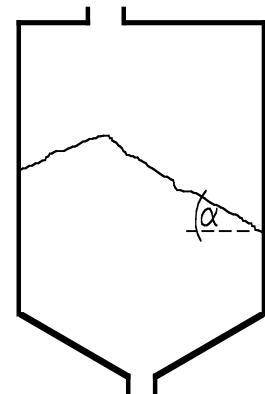

FACTORY DEFAULT: 0

P24: --- a Target tracking speed

a	Tracking speed	Remark
0	Standard	For most applications
1	Fast	For fast changing level
2	Special	Only for special applications (measuring range is reduced to 50% of the nominal value) The measuring window is inactive and the Echotel will respond practically instantly to any target. Recommended to fast target tracking, but usually not applicable for level metering.

FACTORY DEFAULT: 0

P25: - - - a Selection of Echo within the measuring window

A so-called measuring window is formed around the echo signal. The position of this measuring window determines the flight time for calculation of the distance of the target. (the picture below can be seen on the test oscilloscope)

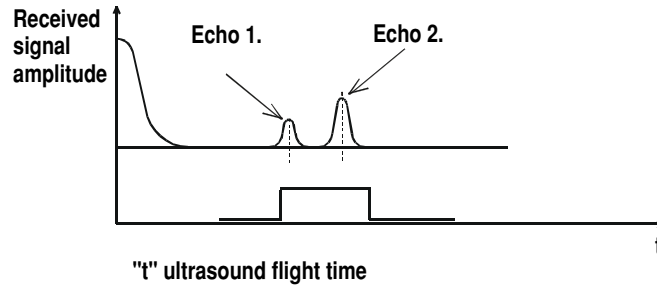

Some applications involve multiple (target + disturbing) echoes even within the measuring window. Basic echo selection will be done by the Quest + software automatically. This parameter only influences the echo selection within the measuring window.

a	Echo in the window to be selected	Remark
0	With the highest amplitude	For most applications (both with liquids and solids)
1	First one	For liquids applications with multiple echoes within the Measuring Window
2	Largest one	Contact factory

FACTORY DEFAULT: 0

P26: (m/h) Level elevation rate (filling speed) Very heavy fuming

P27: (m/h) Level descent rate (emptying speed) Very heavy fuming

Use these parameters to provide additional protection against echo loss in applications involving dust during the filling process in case of very heavy fuming.

These parameters must not be smaller than the fastest possible filling/emptying rate of the actual technology.

For all other applications, use the factory default setting.

FACTORY DEFAULT: for Liquids (P00: Li) P27=2000

P28 - - - a Echo-loss handling

a	Echo-loss error indication	Remark
0	Delayed	During echo-loss, display and analogue output will hold last value. If the echo-loss prevails for 10 sec plus the time period set in P20 (damping time), the reading on the display will change to "no Echo" and the outputs will change according to the "Error Indication Mode" preset in P12.
1	None	For the time of echo-loss, display and analogue output will hold last value.
2	Advance to full	During echo-loss in case of filling, the reading on the display and analogue output will shift towards the "full" tank/silo state with a level elevation rate (filling speed) preset in P26
3	Immediate	In case of echo-loss, the display will immediately change to "no Echo" and the outputs will change according to the "Error Indication Mode" preset in P12.
4	No echo-loss indication in case of empty tank/silo	Echo-loss may occur in completely empty tanks with a spherical bottom due to deflection of the ultrasonic beam, or in case of silos with an open outlet. If the echo is lost when the tank/silo is completely empty, the indication will correspond to empty tank, in all other cases echo-loss indication will function according to the "Delayed".

FACTORY DEFAULT: 0

P29 Blocking out of object #1

P30 Blocking out of object #2

Up to two fix objects in the tank/silo that disturb the measurement can be blocked out.

Enter the distance of the object from the transducer. Use the Echo Map (P70) to read out the precise distance of disturbing objects.

FACTORY DEFAULT: 0

P31: Sound velocity at 20_C (m/sec or ft/sec depending on P00(c))

Use this parameter if the sound velocity in the gases above the measured surface differs largely from that of in air.

Recommended for applications where the gas is more or less homogeneous. If it is not, the accuracy of the measurement can be improved using the 32-point linearisation (P48, P49).

For sound velocities in various gases see section "Sound Velocities".

FACTORY DEFAULT: Metric (P00: "EU"): 343.8 m/s, US (P00: "US"): 1128 ft/s

P32: Specific gravity

If you enter value (other than "0") of specific gravity in this parameter, the weight will be displayed instead of VOL.

FACTORY DEFAULT: 0 [kg/dm³] or [lb/ft³] depending on P00(c)

P33: (m) Manual echo selection by moving the Measuring Window

A so-called measuring window is formed around the echo signal (See scheme on the next page.) The distance of the target will be calculated from the flight time in accordance with the position of the measuring window.

Use this parameter if the Echotel unambiguously selects a wrong echo; for example the echo reflected from the surface is much weaker than the interfering one(s) (see figure beside and on next page).

Enter the distance of the correct echo and the software will move the measuring window and calibrate itself to the echo found there.

To determine the distance of the correct echo, either use the Echo Map (to load-in a value from the Echo Map, see parameter P70), or measure the distance with an appropriate device, and enter this value in P33.

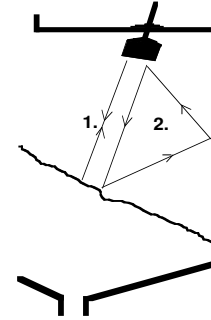

If this parameter has been used (P33 is not 0), its value will be continuously updated with the valid echo position. This means, that in case of a power loss, the Echotel will restart the signal processing with the measuring window at the last updated position. To switch-off this function, set P33= 0.

FACTORY DEFAULT: 0

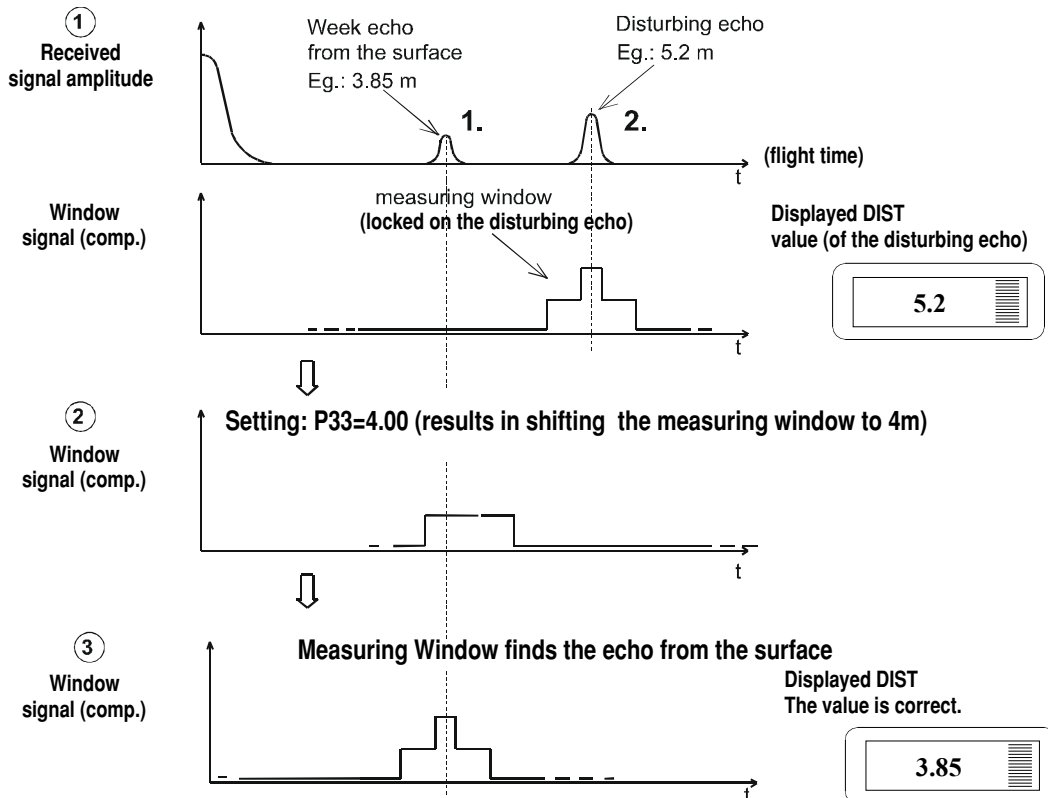

6.5 Volume Calculation

P40: - - ba Tank/silo shape

ba	Tank/silo shape	Also to be set
b0	Standing cylindrical tank shape: value of "b" as below bottom	P40(b), P41
01	Standing cylindrical tank/silo with conical bottom	P41, P43, P44
02	Standing rectangular tank/silo (with chute)	P41, P42, (P43, P44, P45)
b3	Lying cylindrical tank shape: value of "b" as bellow bottom	P40(b), P41, P42
04	Spherical tank	P41

FACTORY DEFAULT: 00

P41-45: Tank/silo dimensions

Standing cylindrical tank/silo with hemispherical bottom

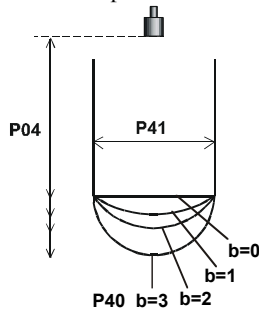

Standing cylindrical tank/silo with conical bottom

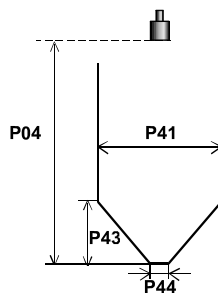

Standing rectangular tank/silo with or without chute

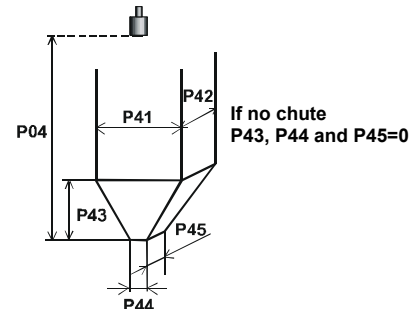

Lying cylindrical tank

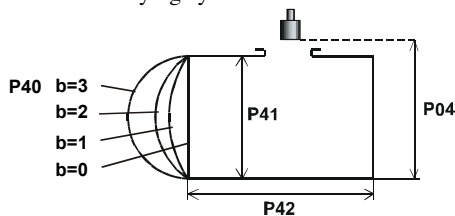

Spherical tank

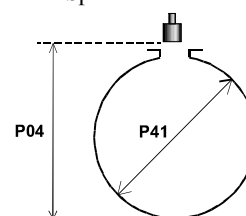

6.6 Volume Flow Measuring

P40: - - ba Appliances, formula, data

ba	Appliances, formula, data					Also to be set:	
	Type	Calculation formula	Qmin [l/s]	Qmax [l/s]	"P" [cm]		
00	Magnetrol Parshall flume	GPA-1P1	$Q[l/s]= 60.87*h^{1.552}$	0.26	5.38	30	P46
01		GPA-1P2	$Q[l/s]= 119.7*h^{1.553}$	0.52	13.3	34	P46
02		GPA-1P3	$Q[l/s]= 178.4*h^{1.555}$	0.78	49	39	P46
03		GPA-1P4	$Q[l/s]= 353.9*h^{1.558}$	1.52	164	53	P46
04		GPA-1P5	$Q[l/s]= 521.4*h^{1.558}$	2.25	360	75	P46
05		GPA-1P6	$Q[l/s]= 674.6*h^{1.556}$	2.91	570	120	P46
06		GPA-1P7	$Q[l/s]= 1014.9*h^{1.556}$	4.4	890	130	P46
07		GPA-1P8	$Q[l/s]= 1368*h^{1.5638}$	5.8	1208	135	P46
08		GPA-1P9	$Q[l/s]= 2080.5*h^{1.5689}$	8.7	1850	150	P46
09	General PARSHALL flume					P46, P42	
10	PALMER-BOWLUS (D/2)					P46, P41	
11	PALMER-BOWLUS (D/3)					P46, P41	
12	PALMER-BOWLUS (Rectangular)					P46, P41, P42	
13	Khafagi Venturi					P46, P42	
14	Bottom-step weir					P46, P42	
15	Suppressed rectangular or BAZIN weir					P46, P41, P42	
16	Trapezoidal weir					P46, P41, P42	
17	Special trapezoidal (4:1) weir					P46, P42	
18	V-notch weir					P46, P42	
19	THOMSON (90°-notch) weir					P46	
20	Circular weir					P46, P41	
21	General flow formula: $Q[l/s]= 1000*P41*h^{P42}$, h [m]					P46, P41, P42	

P41-45: Flume/weir dimensions

See next pages. FACTORY DEFAULT: 0

P46: Distance between transducer face and level of Q=0

P46 is always the distance between the transducer face and the level, where the volume flow is 0. FACTORY DEFAULT: 0

Flume / Weir Dimensions

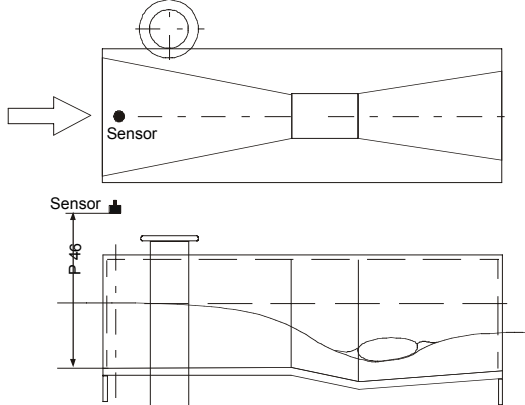
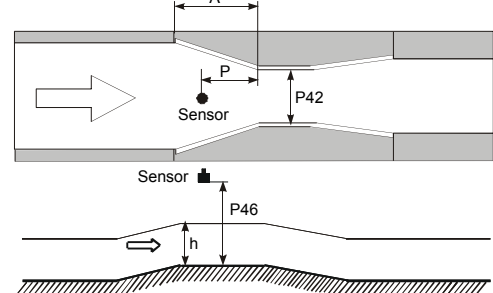
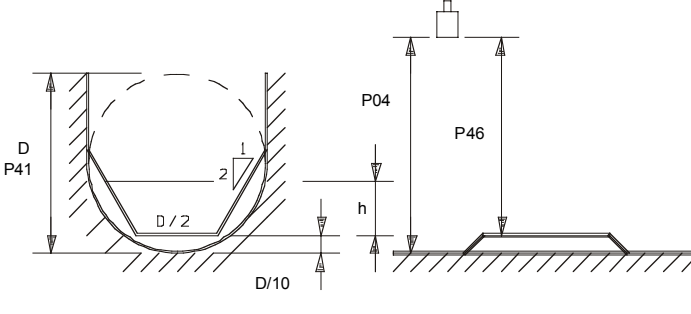
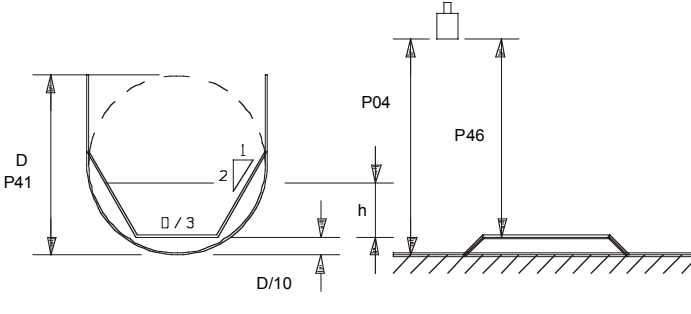
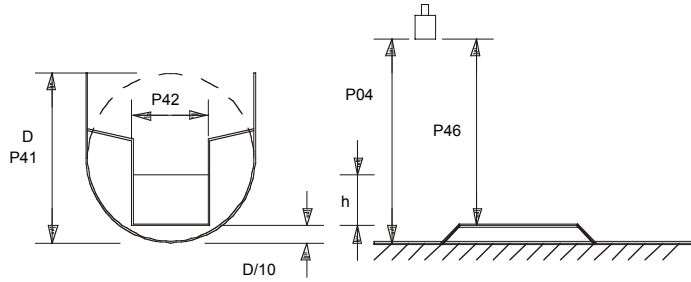
<p>P40= 00 : : 08</p>	<p>Magnetrol Parshall flumes (GPA1P1 ... GPA-1P9) For further details see the Manual of the Parshall flume</p>															
<p>P40= 09</p>	<p>General Parshall flume 0.305 < P42(width) < 2.44</p> $Q[m^3/s] = 0.372 * P42 * (h/0.305)^{1.569 * s}$ <table border="1" data-bbox="526 784 766 974"> <thead> <tr> <th>s[m]</th> <th>K</th> </tr> </thead> <tbody> <tr> <td>3.05</td> <td>2.450</td> </tr> <tr> <td>4.57</td> <td>2.400</td> </tr> <tr> <td>6.10</td> <td>2.370</td> </tr> <tr> <td>7.62</td> <td>2.350</td> </tr> <tr> <td>9.14</td> <td>2.340</td> </tr> <tr> <td>15.24</td> <td>2.320</td> </tr> </tbody> </table> <p>2.5 < P42 $Q[m^3/s] = K * P42 * h^{1.6}$ P = 2/3 * A</p>	s[m]	K	3.05	2.450	4.57	2.400	6.10	2.370	7.62	2.350	9.14	2.340	15.24	2.320	
s[m]	K															
3.05	2.450															
4.57	2.400															
6.10	2.370															
7.62	2.350															
9.14	2.340															
15.24	2.320															
<p>P40= 10</p>	<p>Palmer-Bowlus (D/2) flume $Q[m^3/s] = f(h1/P41) * P41^{2.5}$, where $h1[m] = h + (P41/10)$</p>															
<p>P40= 11</p>	<p>Palmer-Bowlus (D/3) flume $Q[m^3/s] = f(h1/P41) * P41^{2.5}$, where $h1[m] = h + (P41/10)$</p>															
<p>P40= 12</p>	<p>Palmer-Bowlus (Rectangular) flume $Q[m^3/s] = C * P42 * h^{1.5}$, where $C = f(P41/P42)$</p>															

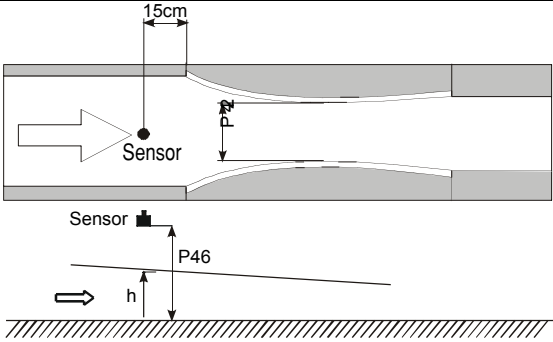
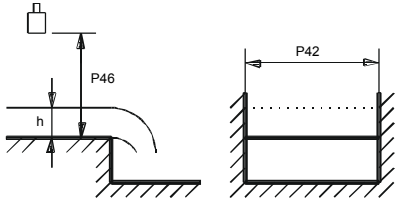
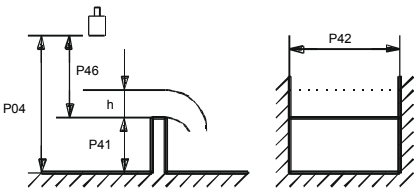
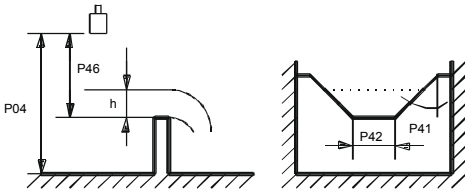
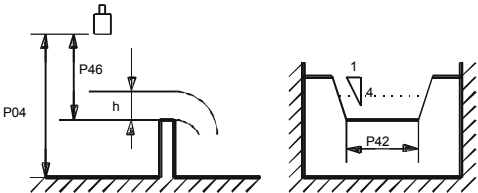
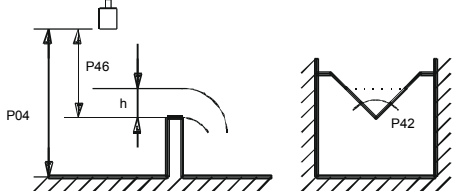
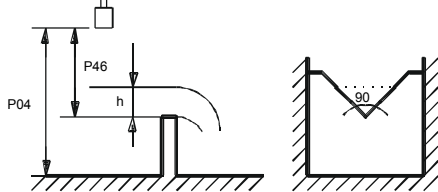
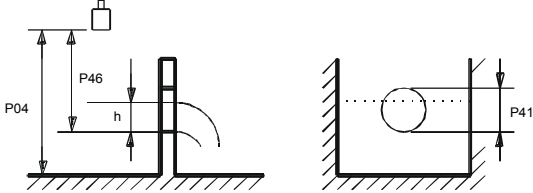
<p>P40= 13</p>	<p>Khafagi Venturi flume</p> $Q[m^3/s]= P42*1.744*h^{1.5} + 0.091*h^{2.5}$	
<p>P40= 14</p>	<p>Bottom step weir</p> $0.0005 < Q[m^3/s] < 1$ $0.3 < P42[m] < 15$ $0.1 < h[m] < 10$ $Q[m^3/s]= 5.073*P42*h^{1.5}$ <p>Accuracy: $\pm 10\%$</p>	
<p>P40= 15</p>	<p>Suppressed rectangular or BAZIN weir</p> $0.001 < Q[m^3/s] < 5$ $0.15 < P41[m] < 0.8$ $0.15 < P42[m] < 3$ $0.015 < h[m] < 0.8$ $Q[m^3/s]= 1.7599*[1+(0.1534/P41)]*P42*(h+0.001)^{1.5}$ <p>Accuracy: $\pm 1\%$</p>	
<p>P40= 16</p>	<p>Trapezoidal weir</p> $0.0032 < Q[m^3/s] < 82$ $20 < P41[^\circ] < 100$ $0.5 < P42[m] < 15$ $0.1 < h[m] < 2$ $Q[m^3/s]= 1.772*P42*h^{1.5}+1.320*tg(P41/2)*h^{2.47}$ <p>Accuracy: $\pm 5\%$</p>	
<p>P40= 17</p>	<p>Special Trapezoidal (4:1) weir</p> $0.0018 < Q[m^3/s] < 50$ $0.3 < P42[m] < 10$ $0.1 < h[m] < 2$ $Q[m^3/s]= 1.866*P42*h^{1.5}$ <p>Accuracy: $\pm 3\%$</p>	
<p>P40= 18</p>	<p>V-notch weir</p> $0.0002 < Q[m^3/s] < 1$ $20 < P42[^\circ] < 100$ $0.05 < h[m] < 1$ $Q[m^3/s]= 1.320*tg(P42/2)*h^{2.47}$ <p>Accuracy: $\pm 3\%$</p>	
<p>P40= 19</p>	<p>THOMSON (90°-notch) weir</p> $0.0002 < Q[m^3/s] < 1$ $0.05 < h[m] < 1$ $Q[m^3/s]= 1.320*h^{2.47}$ <p>Accuracy: $\pm 3\%$</p>	
<p>P40= 20</p>	<p>Circular weir</p> $0.0003 < Q[m^3/s] < 25$ $0.02 < h[m] < 2$ $Q[m^3/s]= m*b*D^{2.5}$ $m= 0.555+0.418h/P41+(P41/(0.11*h))$ <p>Accuracy: $\pm 5\%$</p>	

6.7 32-Point Linearisation Curve

P47: --- a Linearisation

a	Linearisation
0	OFF (FACTORY DEFAULT)
1	ON

P48: Linearisation table

Linearisation is the method of assigning (calibrated or calculated) level, volume or flow to values measured by the transmitter. It can be used eg if the sound velocity is unknown (LEVEL⇒LEVEL) or in case of a vertical cylindrical tank (LEVEL ⇒ VOLUME) etc. Data-pairs of the linearisation table are handled in a 2x32 matrix, consisting of two columns.

Left column "L"	Right column "r"
LEVEL measured	LEVEL or VOLUME or FLOW to be transmitted and displayed

The left column values (indicated on the display as "L") contains the measured LEVEL values.

The right column values (indicated on the display as "r") contains the calibrated values and are interpreted according to the selected measurement value in **P01(a)**.

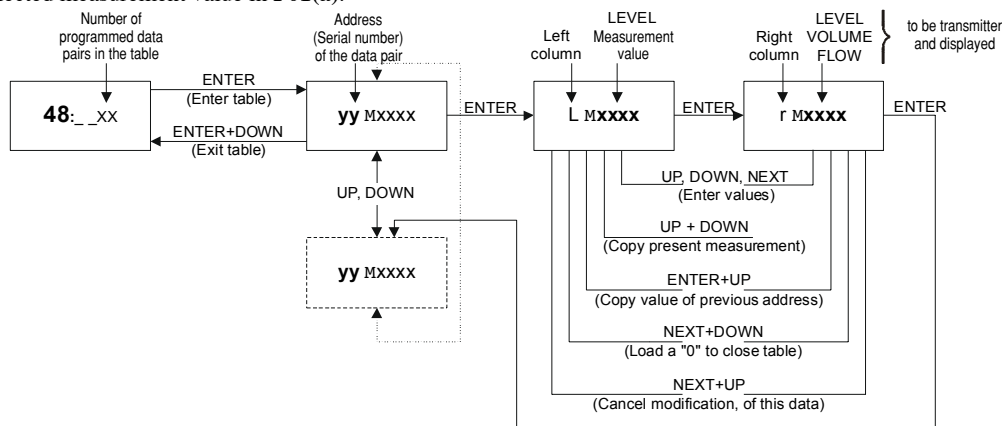

Conditions of correct programming of the data pairs

Left column "L"	Right column "r"
L(1)= 0	r(1)
L(i)	r(i)
:	:
L(j)	r(j)

The table must always start with: L(1)= 0 and r(1)= value (assigned to 0 level)

The table must be ended either with the 32. data pair i.e. j=32

Or if the linearisation table contains less than 32 data-pairs j<32, the table must be closed by a level value "0" e.g. L(j<32)= 0.

The Echotel will ignore data after recognising level value "0" with serial number other than "1".

If the above conditions are not met, error codes will be displayed (see chapter: Error Codes).

6.8 Informational Parameters

P60: (h) Overall operating hours of the unit

Indication varies according to the elapsed time:

Operating hours	Indication form
0 to 999.9h	xxx,x
1000 to 9999h	xxxx
Over 9999h	X,xx: e meaning x,xx 10 ^e

P61: (h) Time elapsed after last switch-on - indication as in P60

P62: (h) Operating hours of the relay - indication as in P60

P63: Number of switching cycle of the relay - indication as in P60

P64: (°C/°F) Actual temperature of the transducer

P65: (°C/°F) Maximum temperature of the transducer

P66: (°C/°F) Minimum temperature of the transducer

In case of a breaking in the temperature measuring Pt10 element „PtErr” will be displayed (See Chapter 7). The transmitter will perform temperature correction corresponding to 20°C.

P70: Number of Echoes / Echo Map

Viewing this parameter gives the number of echoes detected by the system. Entering this parameter will save the actual echo map, and the distance and amplitude of these echoes can be read-out one by one.

To move the Measuring Window manually to one of the echoes displayed in the Echo Map:

- 1). Select an echo in the Echo map (display should indicate the distance of the selected echo)
- 2). Press the UP (▲) + DOWN (▼) keys simultaneously (display will indicate “Set 33”)
- 3). The selected echo is loaded into the P33 parameter (see P33)

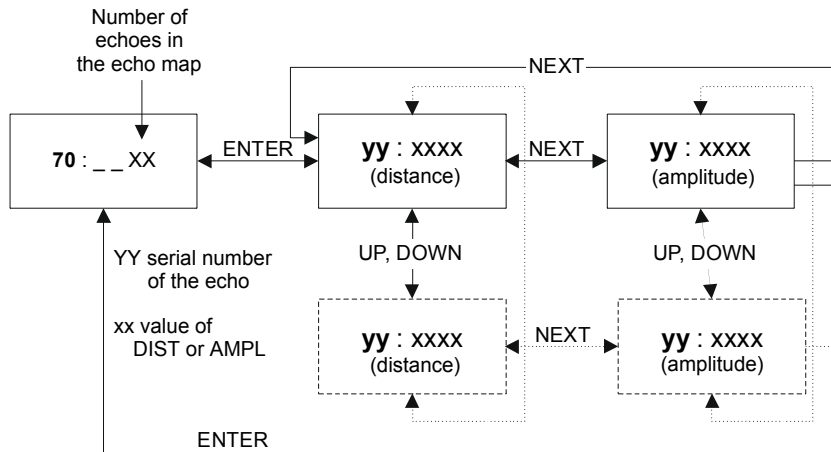

P71: Distance of the of Measuring Window (read-out parameter)

P72 Amplitude of the Echo in the Measuring (read-out parameter)

P73:(msec) Echo Position (time) (read out parameter)

P74: Signal To Noise Ratio (read out parameter)

Ratio	Measurement conditions
Over 70	Excellent
Between 70 and 30	Good
Under 30	Unreliable

P75: Blocking Distance

The actual close-end blocking distance is displayed. Provides useful information if automatic blocking was selected in P05.

6.9 Additional Open Channel Flow Metering Features

P76: (LEV) Head of flow

The Headwater value can be checked here. This is the “h” value in the formula for flow calculation.

P77: TOT1 volume flow totaliser (resetable)

P78: TOT2 volume flow totaliser (non-resetable)

Resetting TOT1 totaliser:

- 1). Go to the parameter P77.
- 2). Press NEXT (⏩) + DOWN (▼) simultaneously.
- 3). Display will indicate: “t1 Clr”.
- 4.) Press ENTER (⏹) for deleting.

6.10 Test Parameters

P80: (mA) Current output test

Entering this parameter will result in displaying the actual current output. Set any value between 3,8 and 20,5 and Press (⏹). Check current output by amp. meter. It has to show the same value set previously. Return to the parameter address by pressing ENTER (⏹).

P81: - - - a Relay test

The actual state of the relay can be seen on the display (code according to the table below and symbol on the screen). Test the relay by pressing UP (▲) and DOWN (▼) while observing change of the symbol and the code or listening to the ticking of the relay or checking on-off resistance by a suitable resistance meter.

a	Relay state
0	De-energised
1	Energised

P97: b:a.aa Software code

- a.aa: Number of the software version
- b: Code of the special version

6.11 Simulation Mode

This function enables the user to test the settings of the outputs. The Echotel can simulate a static or continuous change of level, according to the preset simulation parameters.

Set the required simulation by programming P84, P85, P86 and P87.

P84: - - - x Simulation Mode

X	Simulation type
0	No simulation (FACTORY DEFAULT)
1	The level changes continuously up and down between the level values set in P86 and P87 with a cycle time set in P85
2	Static level simulation: the level will be the value set in P86

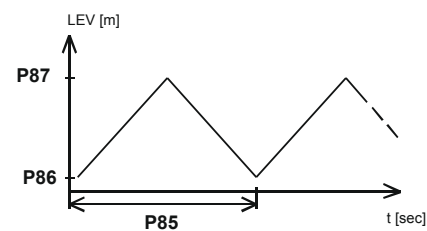

The simulation levels must be within the programmed measuring range: P04 and P05.

P85: (sec) Cycle time for simulation

P86: (m) Simulated low level value

P87: (m) Simulated high level value

To start the simulation mode, return to the measurement mode. While the Echotel is in simulation mode the DIST, LEV or VOL symbol will be blinking.

To quit the simulation mode, set: **P84= 0**.

6.12 Access Lock

P99: dcba Access Lock by Secret Code

The purpose of this feature is to provide protection against accidental (or intentional) re-programming of parameters.

The Secret Code can be a numeric value other than 0000. Setting a Secret Code will automatically be activated when the Echotel is returned to the Measurement Mode. If the Secret Code is activated, the parameters can only be viewed, this is indicated by the a flashing colon ":" between the parameter address and the parameter value.

In order to program the device locked by a secret code, first enter the Secret Code in P99. The Secret Code is re-activated each time the Echotel is returned to Measurement Mode.

To delete the Secret Code, enter the Secret Code in P99. After confirming it with [E] re-enter the parameter P99 and enter 0000.

[dcba (Secret Code)] → [E] → [E] → [0000] → [E] ⇒ Secret Code deleted

7. ERROR CODES

Error Code	Error description	Causes and actions to be done
1	Memory error	Contact local agent
No Echo or 2	Echo loss	No echo received (no reflection)
3	Hardware error	Contact local agent
4	Overflow	Check settings
5	Code referring to sensor error or improper installation/mounting, level in the dead band	Verify sensor for correct operation and check for correct mounting according to Users Manual
6	The measurement is at the reliability threshold (only for free flowing solids level measurement)	Re-aim the sensor or try to find a better location
7	No signal received within the measuring range specified in P04 and P05.	Review programming, also look for installation mistake
12	Linearisation table error: L(1) and L(2) are both zero (no valid data-pairs)	See the Section "Linearisation"
13	Linearisation table error: there are two same L(i) data in the table	See the Section "Linearisation"
14	Linearisation table error: the r(i) values are not monotone increasing	See the Section "Linearisation"
15	Linearisation table error: measured Level is higher than the last Volume or Flow data-pair	See the Section "Linearisation"
16	The checksum of the program in the EEPROM is wrong	Contact local agent
PtErr	Break in the temperature sensor circuit	Contact local agent

SOUND VELOCITIES IN DIFFERENT GASES

The following table contains the sound velocity of various gases measured on **20°C**.

Gases		Sound Velocity (m/s)
Acetaldehyde	C ₂ H ₄ O	252.8
Acetylene	C ₂ H ₂	340.8
Ammonia	NH ₃	429.9
Argon	Ar	319.1
Bensol	C ₆ H ₆	183.4
Carbon dioxide	CO ₂	268.3
Carbon monoxide	CO	349.2
Carbon tetrachloride	CCl ₄	150.2
Chlorine	Cl ₂	212.7
Dimethyl ether	CH ₃ OCH ₃	213.4
Ethane	C ₂ H ₆	327.4
Ethanol	C ₂ H ₃ OH	267.3
Ethylene	C ₂ H ₄	329.4
Helium	He	994.5
Hydrogen sulphide	H ₂ S	321.1
Methane	CH ₄	445.5
Methanol	CH ₃ OH	347
Neon	Ne	449.6
Nitrogen	N ₂	349.1
Nitrogen monoxide	NO	346
Oxygen	O ₂	328.6
Propane N.A.	C ₃ H ₈	246.5
Sulphur hexafluoride	SF ₆	137.8

Par.	Page	Description		Par.	Page	Description
P00	12	Application/Engineering Units		P25	18	Selection of Echo in the measuring window
P01	13	Measurement Mode		P26	18	Level elevation rate (filling speed)
P02	13	Calculation units		P27	18	Level descent rate (emptying speed)
P03	13	Values Displayed-Rounding		P28	18	Echo-loss handling
P04	14	Maximum measuring distance		P29	18	Blocking out of object #1
P05	15	Minimum measuring dist. (Close-end blocking)		P30	18	Blocking out of object #2
P06	15	Far-end blocking		P31	19	Sound velocity at 20_C
P07		N.A.		P32	19	Specific gravity
P08		N.A.		P33	19	Manual echo selection
P09		N.A.		P34		N.A.
P10	16	Value assigned to 4 mA current output		P35		N.A.
P11	16	Value to 20 mA current output		P36		N.A.
P12	16	Error indication by the current output		P37		N.A.
P13	16	Relay function		P38		N.A.
P14	16	Relay parameter – Setpoint value		P39		N.A.
P15	16	Relay parameter – Setpoint value		P40	20/40	Tank/silo shape / Appliances, formula, data
P16	16	Relay parameter – Pulse rate		P41	20/40	Tank/silo dimensions / Flume/weir dimensions
P17		N.A.		P42	20/40	Tank/silo dimensions / Flume/weir dimensions
P18		N.A.		P43	20/40	Tank/silo dimensions / Flume/weir dimensions
P19		N.A.		P44	20/40	Tank/silo dimensions / Flume/weir dimensions
P20		Damping		P45	20/40	Tank/silo dimensions / Flume/weir dimensions
P21		N.A.		P46	21	Dist. btw. transducer face and level of Q=0
P22	17	Dome top tank compensation		P47	23	Linearisation
P23	17	Angle of repos (only for free flowing solids)		P48	23	Linearisation table
P24	17	Target tracking speed		P49		N.A.

P50	N.A.		P75	24	Blocking Distance	
P51	N.A.		P76	24	Head of flow	
P52	N.A.		P77	24	TOT1 volume flow totaliser (resetable)	
P53	N.A.		P78	24	TOT2 volume flow totaliser (non-resetable)	
P54	N.A.		P79		N.A.	
P55	N.A.		P80	24	Current output test	
P56	N.A.		P81	24	Relay test	
P57	N.A.		P82		N.A.	
P58	N.A.		P83		N.A.	
P59	N.A.		P84	25	Simulation Mode	
P60	23	Overall operating hours of the unit	P85	25	Cycle time for simulation	
P61	23	Time elapsed after last switch-on	P86	25	Simulated low level value	
P62	23	Operating hours of the relay	P87	25	Simulated high level value	
P63	23	Number of switching cycle of the relay	P88		N.A.	
P64	23	Actual temperature of the transducer	P89		N.A.	
P65	23	Maximum temperature of the transducer	P90		N.A.	
P66	23	Minimum temperature of the transducer	P91		N.A.	
P67		N.A.	P92		N.A.	
P68		N.A.	P93		N.A.	
P69		N.A.	P94		N.A.	
P70	24	Number of Echoes / Echo Map	P95		N.A.	
P71	24	Distance of the of Measuring Window (read-out parameter)	P96		N.A.	
P72	24	Amplitude of the Echo in the Measuring (read-out parameter)	P97	24	Software code	
P73	24	Echo Position (time) (read out parameter)	P98		N.A.	
P74	24	Signal To Noise Ratio (read out parameter)	P99	25	Access Lock by Secret Code	

Magnetrol

Heikensstraat 6 – 9240 Zele (Belgium)

Phone : ++32 (0)52 45 11 11 – Fax : ++32 (0)52 45 09 93

E-mail : info@magnetrol.com – web : www.magnetrol.com

UNDER RESERVE OF MODIFICATIONS

BULLETIN N°: BE 51-638.0
EFFECTIVE: JULY 2001
SUPERSEDES: New

DEUTSCHLAND	Schloßstraße 76, D-51429 Bergisch Gladbach-Bensberg Tel. (02204) 9536-0 Fax. (02204) 9536-53
FRANCE	Le Vinci 6 - Parc d'activités de Mitry Compans, 1, rue Becquerel, 77290 Mitry Mory Tél. 01.60.93.99.50 Fax. 01.60.93.99.51
ITALIA	Via Arese 12, I-20159 Milano Tel. (02) 607.22.98 (R.A.) Fax. (02) 668.66.52
UNITED KINGDOM	Unit 1 Regent Business Centre Jubilee Road Burgess Hill West Sussex RH 15 9TL Tel. (01444) 871313 Fax (01444) 871317
INDIA	B4/115 Safdurjung Enclave, New Delhi 110 029 Tel. 91 (11) 6186211 Fax 91 (11) 6186418