

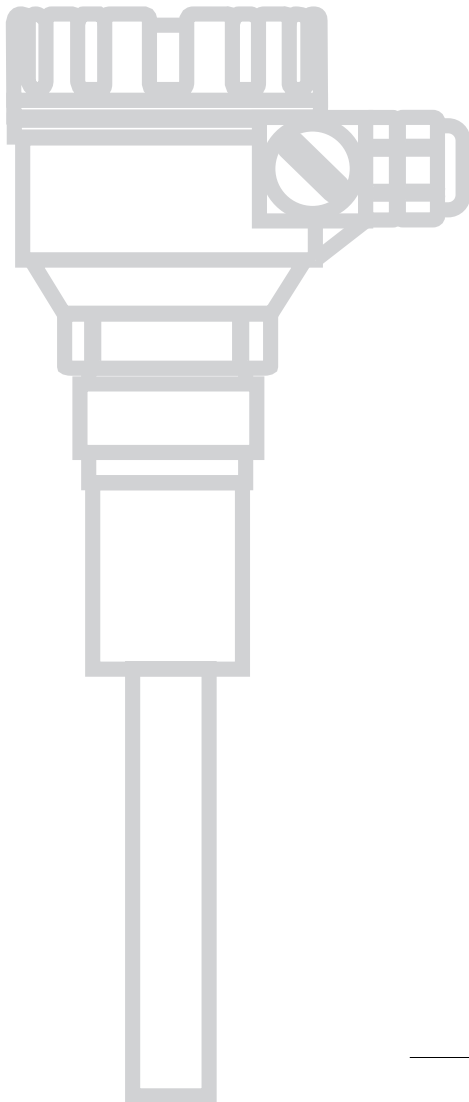

Installation and Operating Manual

*Vibrating Rod
Level Switch
for Solids*



7xxx



6xxx

5xxx



4xxx

3xxx

2xxx

1xxx

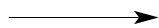

UNPACKING

Unpack the instrument carefully. Make sure all components have been removed from the foam protection. Inspect all components for damage. Report any concealed damage to the carrier within 24 hours. Check the contents of the carton/crates against the packing slip and report any discrepancies to Magnetrol. Check the nameplate model number (Model number/approvals as per inserted separate sheet) to be sure it agrees with the packing slip and purchase order. Check and record the serial number for future reference when ordering parts.



These units are in compliance with:

1. The EMC directive 89/336/EEC. The units have been tested to EN 61000-6-4 and EN 61000-6-2.
2. The ATEX directive 94/9/EC. EC-Type examination number DMT 03ATEX E037 (4 th digit A only).
3. The PED directive 97/23/EC (pressure equipment directive). Safety accessories per category IV module H1.



MOUNTING

The Solitel can easily be bench tested prior to installation. Power the unit and insert the vibrating part in a sample of the medium. When the unit does not react properly, the density setting of the unit needs to be adjusted (see WIRING).

Correct mounting

A deflection plate is required when the probe is exposed to falling material or, in case of a low level switch, when the drag force of the emptying material exceed the specifications.

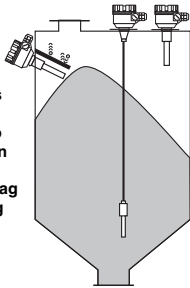

Incorrect mounting

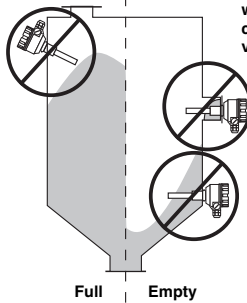

Avoid mounting the sensor in a recess where build-up could dampen the vibration.

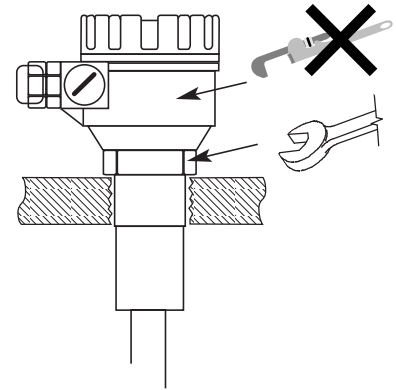

Caution:

- Units with extended flexible sensor:
 - Low level alarms: Install these in line with the outlet of the tank (as shown in the above left picture).
 - A higher Pull force (F) of 45 kN, will cause the cable to break and will permanently damage the unit.
- Units with standard / extended rigid sensor:
 - Side mounted: Install these under a preferred angle of 45°. This will assure a proper functioning of the self-cleaning of the rod (as shown in the above left picture).
 - Higher mechanical loads than 85 Nm (M), will cause permanent damage to the unit. Avoid to install as low level alarm in media with high SG.

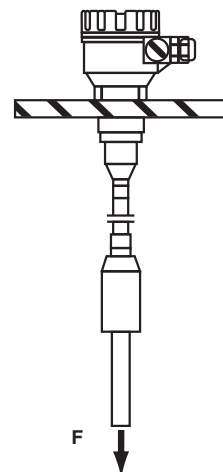
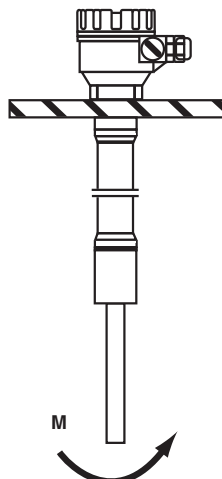
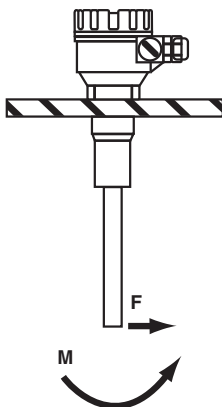

WIRING/SETTING

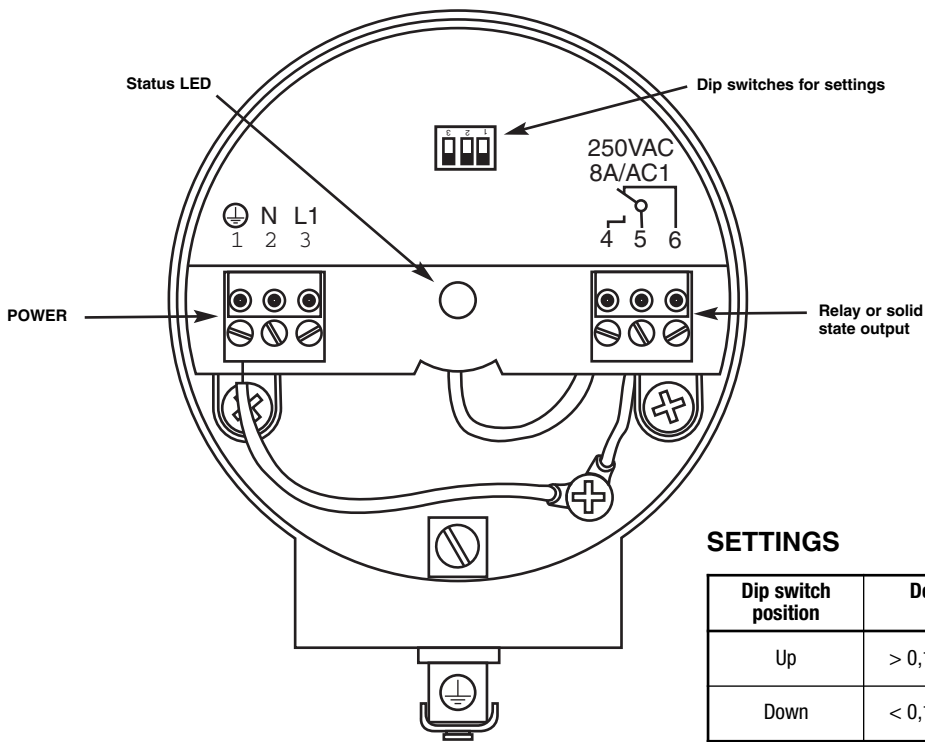

SETTINGS

Dip switch position	Density 3	Time delay 2	Failsafe 1
Up	> 0,1 kg/dm ³	5 s	Low level
Down	< 0,1 kg/dm ³	2 s	High level

16 .. 40 V AC (50/60 Hz) / 19 .. 55 V DC
 85 .. 265 V AC (50/60 Hz) / 120 .. 375 V DC

OUTPUT DIAGRAM

Failsafe mode	Level	Relay status	Relay output	Solid state output
High level		Green		
		Red		
Low level		Green		
		Red		
No power	High/Low level	Not lit		

SPDT Relay (8 A @ 250 V AC / 1 A @ 24 V DC)

85 ... 265 V AC / 120 ... 375 V DC or 19 ... 55 V DC / 16 ... 40 V AC

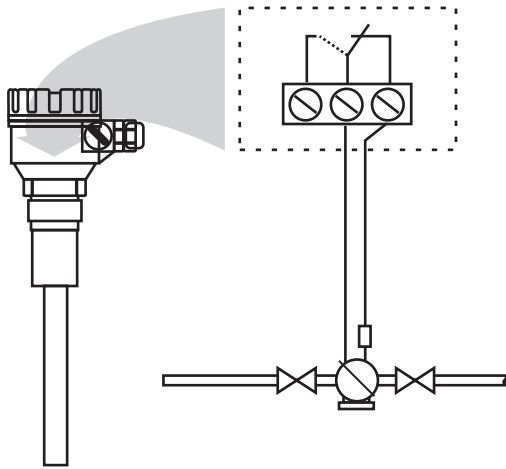

Solid State output

85 ... 265 V AC / 120 ... 375 V DC or 19 ... 55 V DC / 16 ... 40 V AC

Connection to an opto-coupled input

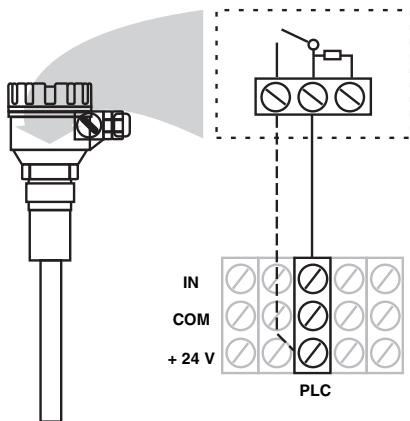

Connection to a logical voltage input

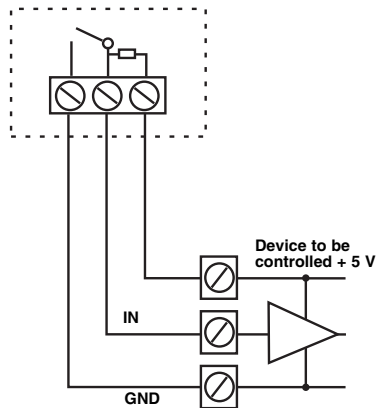

Connection to a load

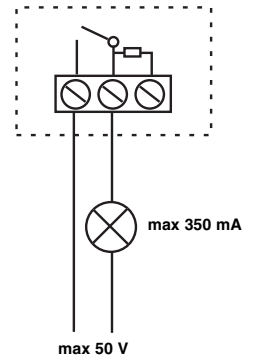

REPLACEMENT PARTS

Electronic module for model:	Partnumber
VSx-S2BA-xxx	030-9015-001
VSx-S2BD-xxx	030-9015-002
VSx-S2EA-xxx	030-9015-003
VSx-S2ED-xxx	030-9015-004
VHx-S2BA-xxx	030-9015-005
VHx-S2BD-xxx	030-9015-006
VHx-S2EA-xxx	030-9015-007
VHx-S2ED-xxx	030-9015-008

NOTE: Dust Ex units need to return to factory for repair.

REPLACEMENT PROCEDURE FOR ELECTRONIC MODULE:

The replacement electronic modules are delivered unassembled to ease the tuning from the sensor to the electronics. This simple procedure allows to replace the module in the field, without dismantling the unit.

Step 1: Switch off power and unplug both power and output terminal blocks.
Loosen the two screws in the base of the housing to remove electronic module.

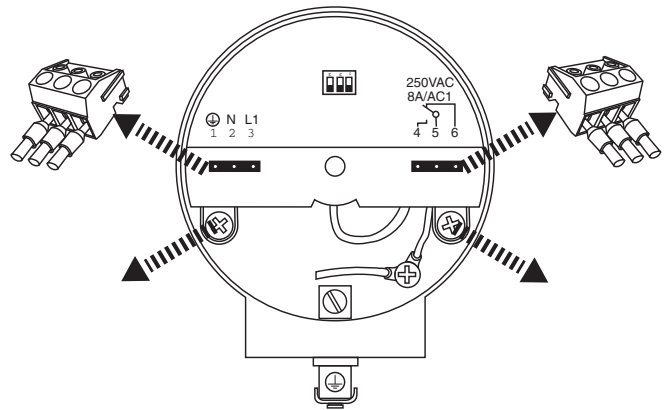

Step 2: Snap off the cover of the new module, so that the internals of the module are visible. Refasten the new module in the base of the housing and plug in the power block.

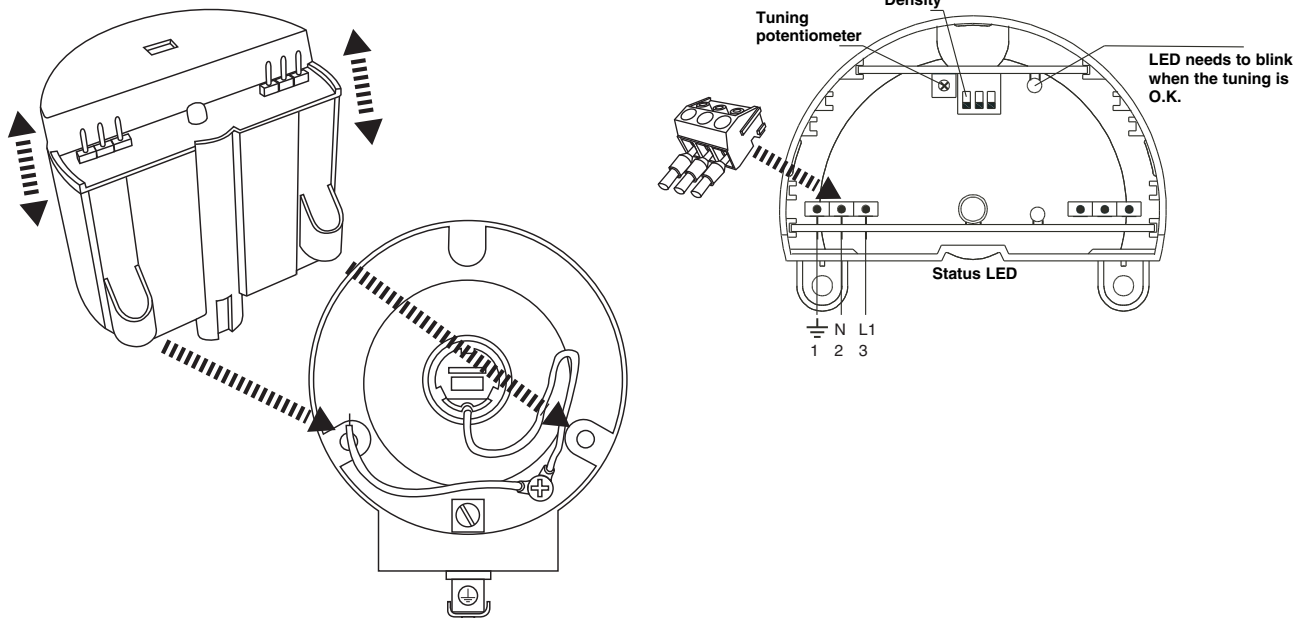

Step 3: Turn power on and

- put the density dip switch "3" in the Low (down) position
- the internals of the electronic module show a potentiometer and an LED. Tweak the potentiometer until the LED lights up. The electronics are now tuned with the electronics. Remove power block to snap the cover onto electronic module and reconnect power block.

Step 4: Adjust the settings as per initial setting (see WIRING on page 3) and reconnect the output block.

SPECIFICATIONS

PERFORMANCE

Description	Specification
Response time	< 1,8 s (when covered) – 2 s (when free) or with time delay: 5 s + 1,5 s (field selectable)
Electromagnetic compatibility	Meets CE requirements (EN 61000-6-4, EN 61000-6-2)

PHYSICAL/FUNCTIONAL SPECIFICATIONS

Description	Specification
Input voltage	85 ... 265 V AC / 120 ... 375 V DC or 19 ... 55 V DC / 16 ... 40 V AC
Power consumption	1.3 VA
Signal output	8 A SPDT relay @ 250 V AC (1A @ 24 V DC) Solid state output - 350 mA / 50 V peak
Indication	Output status LED (green/red) – visual indication on cover
Housing material	IP 67, Aluminium (2x M20 x 1,5 and 2 x 1/2" NPT - all plugged) 2 x M20 x 1,5 cable gland separately included
Approvals	ATEX II 1/2 D IP 65
Sensor material	All wetted parts of polished 316 Ti SST (1.4571) (except VSK) PE coated cable (VSK)
Mounting	Threaded: 1 1/2" BSP (G 1 1/2)
Actuation length	VSH/VHH: 235 mm (9.2") VSR/VHR: from 500 mm up to 3000 mm (19.7" up to 9.8') VSK: from 1 m up to 20 m (3.3' up to 65.6')
Max pressure	25 bar abs. (360 psia) Flexible version VSK: 6 bar abs. (87 psia)
Min density	0,05 kg/dm ³ - max granular size: 10 mm (0,39")
Max mechanical load on sensor	VSH/VHH: 85 Nm
Weight of unit	2,5 kg (VSH/VHH) + 1,4 kg/m for VSR/VHR + 0,6 kg/m for VSK

Description		Process temp.	Ambient temp.	temp. at process conn.
Max temperature	VSH/VSR	-30 °C to +110 °C (-20 °F to +230 °F)	-30 °C to +50 °C (-20 °F to +120 °F)	max +90 °C (+195 °F)
	VHH/VHR	-30 °C to +160 °C (-20 °F to +320 °F)	-30 °C to +35 °C (-20 °F to +95 °F)	max +135 °C (+275 °F)
	VSK	-35 °C to +95 °C (-30 °F to +200 °F)	-30 °C to +60 °C (-20 °F to +140 °F)	max +85 °C (+185 °F)

AMBIENT TEMPERATURE (T_A) VERSUS PROCESS TEMPERATURE (T_P)

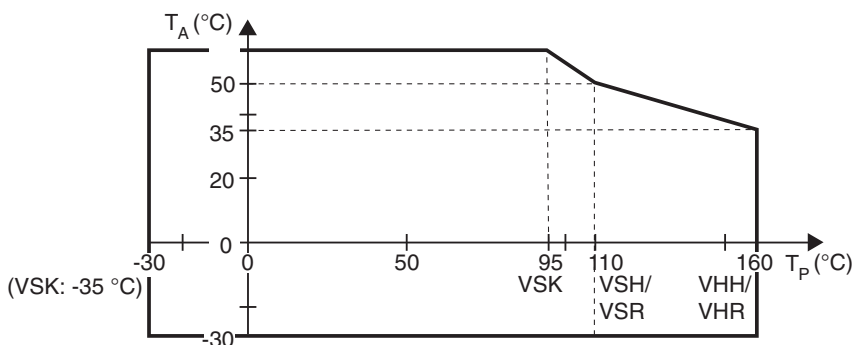

MODEL IDENTIFICATION

A complete measuring system consists of:

1. One code for electronics and sensor
2. Optional: threaded mounting flanges – consult factory

1. One code for electronics and sensor

BASIC MODEL NUMBER

Standard electronics - max process temperature 110 °C (230 °F) - 90 °C (200 °F) for flexible version

V S H	Solitel with STANDARD sensor	- 235 mm (9.2") insertion length
V S R	Solitel with EXTENDED RIGID sensor	- selectable insertion length / 10 cm (3.9") increments
V S K	Solitel with FLEXIBLE sensor	- selectable insertion length / 1 m (3.3') increments

High temperature electronics - max process temperature 160 °C (320 °F)

V H H	Solitel with STANDARD sensor	- 235 mm (9.2") insertion length
V H R	Solitel with EXTENDED RIGID sensor	- selectable insertion length / 10 cm (3.9") increments

HOUSING MATERIAL / CABLE ENTRY / APPROVAL – IP 67

S	Aluminium, 4 entries (2x M20 x 1,5 and 2 x 1/2" NPT - all plugged)	General purpose
A	Aluminium, 4 entries (2x M20 x 1,5 and 2 x 1/2" NPT - all plugged)	ATEX II 1/2 D IP 65 (Dust Ex)

SIGNAL OUTPUT

2 B	8 A SPDT relay
2 E	Solid state output 350 mA / 50 V

POWER SUPPLY

A	85 .. 265 V AC / 120 .. 375 V DC
D	19 .. 55 V DC / 16 .. 40 V AC

INSERTION LENGTH

0 0 0	VSH/VHH:	235 mm (9.2")
0 5 0	VSR/VHR:	min 50 cm (19.7")
3 0 0		max 300 cm (9.8"), Specify length in 10 cm (3.9") increments
0 0 1	VSK:	min 1 m (3.3')
0 2 0		max 20 m (65.60'), Specify length in 1 m (3.3') increments

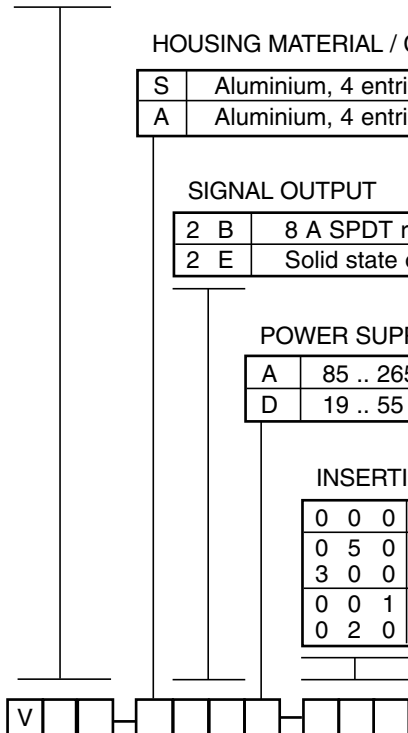

complete code for SOLITEL electronics and sensor

DIMENSIONS IN mm (inches)

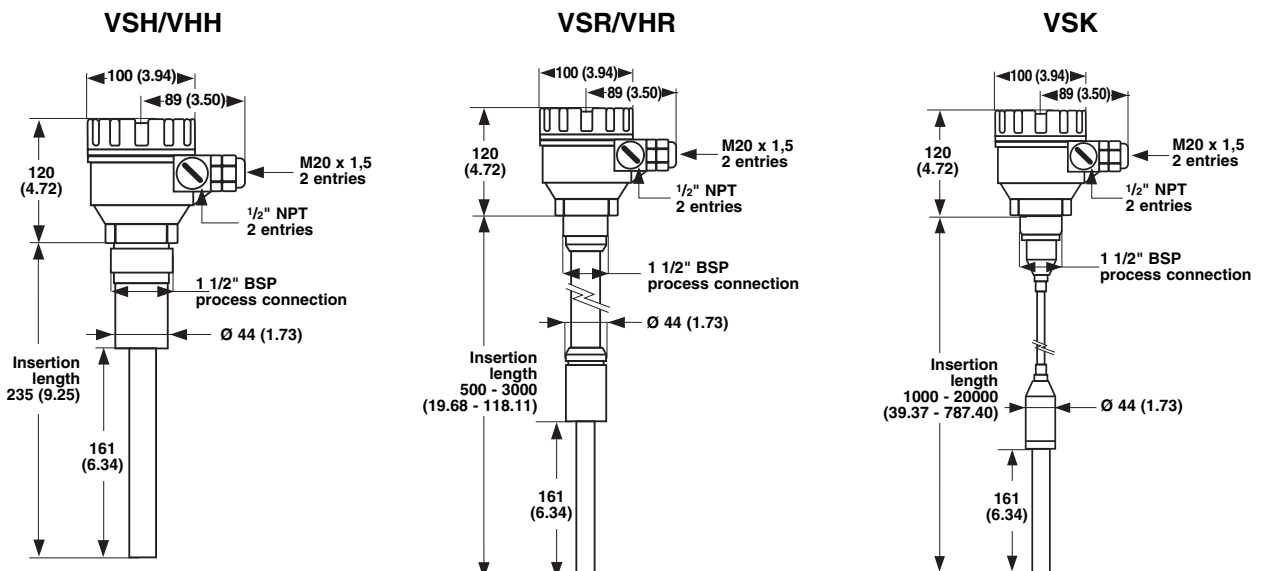

IMPORTANT

SERVICE POLICY

Owners of Magnetrol products may request the return of a control; or, any part of a control for complete rebuilding or replacement. They will be rebuilt or replaced promptly. Magnetrol International will repair or replace the control, at no cost to the purchaser, (or owner) **other than transportation cost** if:

- a. Returned within the warranty period; and,
- b. The factory inspection finds the cause of the malfunction to be defective material or workmanship.

If the trouble is the result of conditions beyond our control; or, is **NOT** covered by the warranty, there will be charges for labour and the parts required to rebuild or replace the equipment.

In some cases, it may be expedient to ship replacement parts; or, in extreme cases a complete new control, to replace the original equipment before it is returned. If this is desired, notify the factory of both the model and serial numbers of the control to be replaced. In such cases, credit for the materials returned, will be determined on the basis of the applicability of our warranty.

No claims for misapplication, labour, direct or consequential damage will be allowed.

RETURNED MATERIAL PROCEDURE

So that we may efficiently process any materials that are returned, it is essential that a "Return Material Authorisation" (RMA) form will be obtained from the factory. It is mandatory that this form will be attached to each material returned. This form is available through Magnetrol's local representative or by contacting the factory. Please supply the following information:

1. Purchaser Name
2. Description of Material
3. Serial Number and Ref Number
4. Desired Action
5. Reason for Return
6. Process details

All shipments returned to the factory must be by prepaid transportation. Magnetrol **will not accept** collect shipments. All replacements will be shipped FOB factory.

BULLETIN N°: BE 51-639.2
EFFECTIVE: MAY 2007
SUPERSEDES: March 2003

UNDER RESERVE OF MODIFICATIONS



www.magnetrol.com

BENELUX	Heikensstraat 6, 9240 Zele, België Tel. +32 (0)52.45.11.11 • Fax. +32 (0)52.45.09.93 • E-Mail: info@magnetrol.be
DEUTSCHLAND	Alte Ziegelei 2-4, D-51491 Overath Tel. 02204 / 9536-0 • Fax. 02204 / 9536-53 • E-Mail: vertrieb@magnetrol.de
FRANCE	40 - 42, rue Gabriel Péri, 95130 Le Plessis Bouchard Tél. 01.34.44.26.10 • Fax. 01.34.44.26.06 • E-Mail: magnetrolfrance@magnetrol.fr
ITALIA	Via Arese 12, I-20159 Milano Tel. (02) 607.22.98 (R.A.) • Fax. (02) 668.66.52 • E-Mail: mit.gen@magnetrol.it
UNITED KINGDOM	Unit 1 Regent Business Centre, Jubilee Road Burgess Hill West Sussex RH 15 9TL Tel. (01444) 871313 • Fax (01444) 871317 • E-Mail: sales@magnetrol.co.uk
INDIA	C-20 Community Centre, Janakpuri, New Delhi - 110 0058 Tel. 91 (11) 41661840 • Fax 91 (11) 41661843 • E-Mail: info@magnetrolindia.com