

# Model R82

R82 software v1.0a

## Installation and Operating Manual

*Pulse Burst Radar  
Level Transmitter*



---

## Read this Manual Before Installing

This manual provides information on the R82 Radar transmitter. It is important that all instructions are read carefully and followed in sequence. The *QuickStart Installation* instructions are a brief guide to the sequence of steps for experienced technicians to follow when installing the equipment. Detailed instructions are included in the *Complete Installation* section of this manual.

## Conventions Used in this Manual

Certain conventions are used in this manual to convey specific types of information. General technical material, support data, and safety information are presented in narrative form. The following styles are used for notes, cautions, and warnings.

### NOTES

Notes contain information that augments or clarifies an operating step. Notes do not normally contain actions. They follow the procedural steps to which they refer.

### Cautions

Cautions alert the technician to special conditions that could injure personnel, damage equipment, or reduce a component's mechanical integrity. Cautions are also used to alert the technician to unsafe practices or the need for special protective equipment or specific materials. In this manual, a caution box indicates a potentially hazardous situation which, if not avoided, may result in minor or moderate injury.

### WARNINGS

Warnings identify potentially dangerous situations or serious hazards. In this manual, a warning indicates an imminently hazardous situation which, if not avoided, could result in serious injury or death.

### Safety Messages

The Through-Air Radar system is designed for use in Category II, Pollution Degree 2 installations. Follow all standard industry procedures for servicing electrical and computer equipment when working with or around high voltage. Always shut off the power supply before touching any components. Although high voltage is not present in this system, it may be present in other systems.

Electrical components are sensitive to electrostatic discharge. To prevent equipment damage, observe safety procedures when working with electrostatic sensitive components.

### Low Voltage Directive

For use in Installations Category II, Pollution Degree 2. If equipment is used in a manner not specified by the manufacturer, protection provided by equipment may be impaired.

---

NOTE: This equipment has been tested and found to comply with the limits for a Class B digital device, pursuant to Part 15 of the FCC Rules. These limits are designed to provide reasonable protection against harmful interference in a residential installation. This equipment generates, uses and can radiate radio frequency energy and, if not installed and used in accordance with the instructions, may cause harmful interference to radio communications. However, there is no guarantee that interference will not occur in a particular installation. If this equipment does cause harmful interference to the

radio or television reception, which can be determined by turning the equipment off and on, the use is encouraged to try to correct the interference by one or more of the following measures:

- Reorient or relocate the receiving antenna.
- Increase the separation between the equipment and receiver.
- Connect the equipment into an outlet on a circuit different from that to which the receiver is connected.
- Consult the dealer or an experienced radio/TV technician for help.

Any unauthorized changes or modifications not expressly approved by Magnetrol International, Incorporated could void user's authority to operate this equipment.

**WARNING!** Explosion hazard. Do not connect or disconnect designs rated Explosion-proof or Non-incendive unless power has been switched off and/or the area is known to be non-hazardous

### Notice of Copyright and Limitations

Magnetrol & Magnetrol logotype are registered trademarks of Magnetrol International.

Copyright © 2009 Magnetrol International, Incorporated  
All rights reserved.

Performance specifications are effective with date of issue and are subject to change without notice. Magnetrol reserves the right to make changes to the product described in this manual at any time without notice. Magnetrol makes no warranty with respect to the accuracy of the information in this manual.

### Warranty

All Magnetrol electronic level and flow controls are warranted free of defects in materials or workmanship for one full year from the date of original factory shipment.

If returned within the warranty period; and, upon factory inspection of the control, the cause of the claim is determined to be covered under the warranty; then, Magnetrol will repair or replace the control at no cost to the purchaser (or owner) other than transportation.

Magnetrol shall not be liable for misapplication, labor claims, direct or consequential damage or expense arising from the installation or use of equipment. There are no other warranties expressed or implied, except special written warranties covering some Magnetrol products.

### Quality Assurance

The quality assurance system in place at Magnetrol guarantees the highest level of quality throughout the company. Magnetrol is committed to providing full customer satisfaction both in quality products and quality service.

Magnetrol's quality assurance system is registered to ISO 9001 affirming its commitment to known international quality standards providing the strongest assurance of product/service quality available.





# Model R82 Pulse Burst Radar Level Transmitter

## Table of Contents

<b>1.0 QuickStart Installation</b>	
1.1 Getting Started.....4	
1.1.1 Equipment and Tools .....4	
1.1.2 Configuration Information.....5	
1.2 QuickStart Mounting.....6	
1.2.1 Transmitter/Antenna .....6	
1.3 QuickStart Wiring .....6	
1.4 QuickStart Configuration .....7	
<b>2.0 Complete Installation</b>	
2.1 Unpacking .....9	
2.2 Electronic Discharge (ESD) Handling Procedure.....9	
2.3 Before You Begin.....10	
2.3.1 Site Preparation .....10	
2.3.2 Equipment and Tools .....10	
2.3.3 Operational Considerations.....10	
2.3.3.1 Maximum Distance.....10	
2.3.3.2 Minimum Distance.....10	
2.3.3.3 Problematic Applications; GWR Alternative .....11	
2.4 Mounting.....12	
2.4.1 Installing the Antenna .....12	
2.4.1.1 Location.....12	
2.4.1.2 Beam Angle.....12	
2.4.1.3 Obstructions .....13	
2.4.1.4 Nozzles.....13	
2.4.1.5 Stillwells .....14	
2.4.2 Installing the Transmitter .....14	
2.4.2.1 Orientation .....14	
2.4.2.2 Initial Installation.....15	
2.4.2.3 Poor Echo Strength .....15	
2.5 Wiring .....16	
2.5.1 General Purpose or Non-Incendive .....16	
2.5.2 Intrinsically Safe.....16	
2.6 Configuring the Transmitter.....17	
2.6.1 Operating Parameters.....17	
2.6.2 Setting Up for Shop Configuration .....17	
2.6.3 Transmitter Display and Keypad .....17	
2.6.4 Menu Traversal and Data Entry.....18	
2.6.4.1 Navigating Menu.....18	
2.6.4.2 Data Selection .....18	
2.6.4.3 Entering Numeric Data Using Digit Entry.....18	
2.6.4.4 Entering Numeric Data Using Increment/Decrement .....19	
2.6.4.5 Entering Character Data .....19	
2.6.5 Password Protection (Default = 0) .....20	
2.6.6 Menu: Step-By-Step Procedure.....21	
2.6.6.1 Radar Transmitter User Menu .....22	
2.6.6.2 Radar Transmitter Factory Menu .....26	
2.6.7 HART Menu.....27	
<b>3.0 Reference Information</b>	
3.1 Description .....29	
3.2 Theory of Operation.....29	
3.2.1 Pulse Burst Radar .....29	
3.2.2 Equivalent Time Sampling .....30	
3.3 Troubleshooting .....31	
3.3.1 System Problems .....31	
3.3.2 Error Messages .....32	
3.4 Agency Approvals.....35	
3.4.1 Agency Drawing and Entity Parameters .....36	
3.5 Parts.....37	
3.5.1 Replacement Parts .....37	
3.5.2 Recommended Spare Parts .....37	
3.6 Specifications .....38	
3.6.1 Functional – Transmitter .....38	
3.6.2 Performance .....39	
3.6.3 Functional.....40	
3.6.4 Antenna Pressure/Temperature Ratings .....40	
3.6.5 Physical .....41	
3.7 Model Numbers.....42	
3.7.1 R82 Radar Transmitter.....42	
<b>Glossary</b> .....43	
<b>Model R82 Configuration Data Sheet</b> .....46	

---

## 1.0 QuickStart Installation

The QuickStart Installation procedures provide the key steps for mounting, wiring, and configuring the R82 radar level transmitter. These procedures are intended for experienced installers of electronic level measurement instruments. See Complete Installation, Section 2.0, for detailed installation instructions.

### 1.1 Getting Started

Before beginning the QuickStart Installation procedures, have the right equipment, tools, and information available.

#### 1.1.1 Equipment and Tools

No special tools are needed. The following items are recommended:

- Threaded antenna and transmitter . . . . . 2" (50 mm)
- Flat-blade screwdriver
- Digital multimeter or volt/ammeter . . . . . Optional
- 24 VDC (23 mA) power supply. . . . . Optional

### 1.1.2 Configuration Information

Some key information is needed to configure the R82 radar transmitter. Complete the following operating parameters table before beginning configuration.

NOTE: The transmitter will already be configured if this information was provided with the order.

Display	Question	Answer
Units	What units of measurement will be used?	
	Will the unit measure in Level or Volume?	
	What are the Volume units?	
	What is the relationship between Level and Volume? (Enter up to 20 points)	
Sensor Offset	What is the distance from the top (100%) of the tank and the Sensor Reference point? (bottom of NPT thread, top of BSP thread, or face of flange?)	
Tank Top	Is the Tank Top Flat, Horizontal Cylinder, Dome, Irregular or Other (non-metallic)?	
Tank Height	What is the tank height? NOTE: $Sensor\ Offset + Tank\ Height = Distance\ from\ process\ connection\ to\ tank\ bottom$	
Blocking Distance	Default of 15" (375 mm) is the minimum distance from the process connection to the maximum level. Extend this value when necessary to block reflections from objects close to the antenna.	
Level Offset	Is there a region at the very bottom of the vessel that cannot be measured due to heating coils, angle tank bottom, etc.?	
Dielectric	What is the dielectric of the process medium?	
Turbulence	Is turbulence a consideration?	
Foam	Will there be foam on the surface?	
Rate of Change	What is the maximum rate the level will rise or fall?	
4.0 mA Setpoint	What is the 0% reference point for the 4.0 mA value?	
20.0 mA Setpoint	What is the 100% reference point for the 20.0 mA value?	

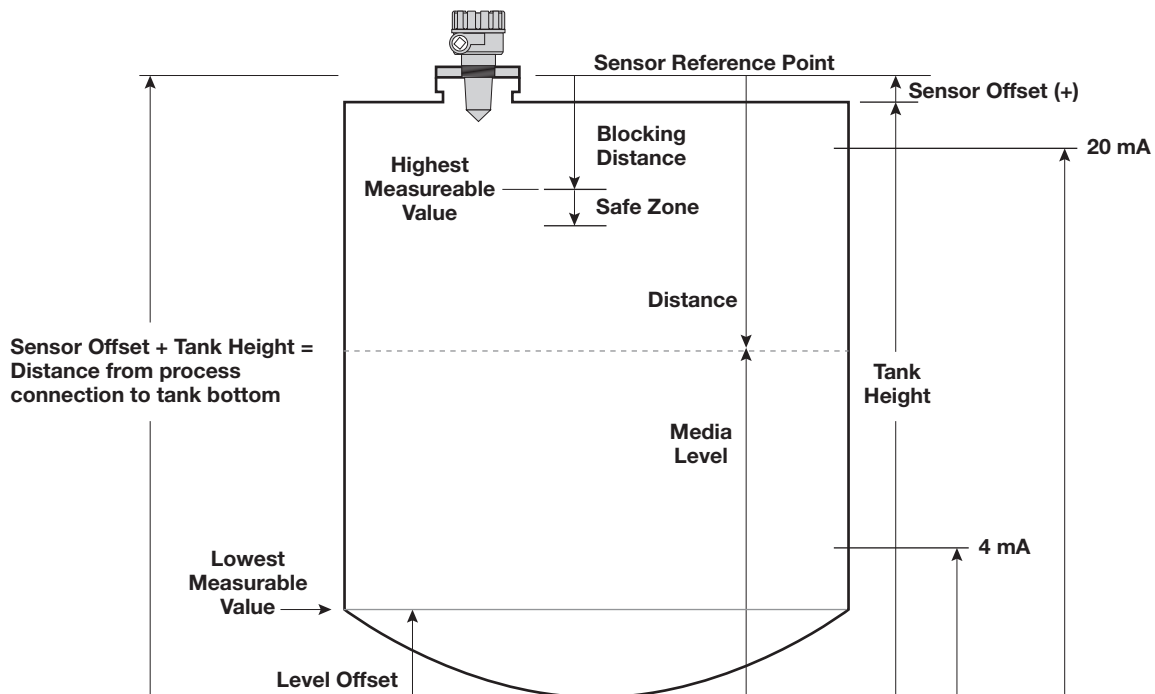

Figure 1

## 1.2 QuickStart Mounting

### 1.2.1 Transmitter/Antenna

1. The device is manufactured as one unit that includes the transmitter and antenna.
2. Remove any protective material from the antenna before installing.
3. Install the transmitter/antenna into the process connection. If threaded, tighten securely by hand using the housing for grip. Ensure there is no cross-threading and do not over tighten as this may cause damage to the plastic threads.
4. Adjust the beam position by turning the internal launcher adjustment (Figure 2). The internal launcher adjustment is numbered 1-18 that equates to 10-180 degrees of adjustment; 9 is the midpoint. The polarization pattern is parallel to the transmitter display when the adjustment mechanism is in the #11 position (factory default). After positioning the transmitter display, the launcher should be adjusted so the polarization pattern is parallel to a line tangent to the nearest tank wall (Figure 3). Do not optimize the Echo Strength at one level in the vessel.
  - Do not place insulating material around any part of the Radar transmitter including the antenna process connection.

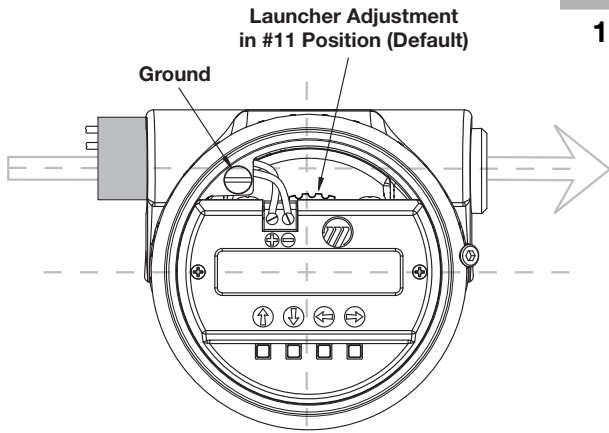

Figure 2

Polarization pattern when launcher is in the #11 Position (default)

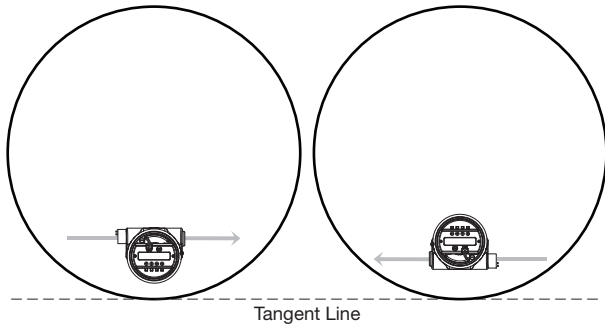

Figure 3

Polarization shown parallel to tangent line; either orientation is acceptable

### 1.3 QuickStart Wiring

NOTE: Make sure the electrical wiring to the R82 radar transmitter is complete and in compliance with all regulations and codes.

1. Remove the cover of the wiring compartment.
2. Attach a conduit fitting and mount the conduit plug in the spare opening. Pull the power supply wire through the conduit fitting.
3. Connect shield to an earth ground at power supply and leave floating at the transmitter.
4. Connect the positive supply wire to the (+) terminal and the negative supply wire to the (-) terminal.
5. Seal conduit to prevent ingress of moisture.
6. Replace cover of the transmitter.

## 1.4 QuickStart Configuration

The Radar transmitter comes factory-calibrated and can be configured in minutes for specific applications. Bench configuration provides a convenient and efficient way to set up the transmitter before going to the tank site to complete the installation. The minimum configuration instructions follow. Use the information from the operating parameters table before beginning configuration. See Configuration Information, Section 1.1.2.

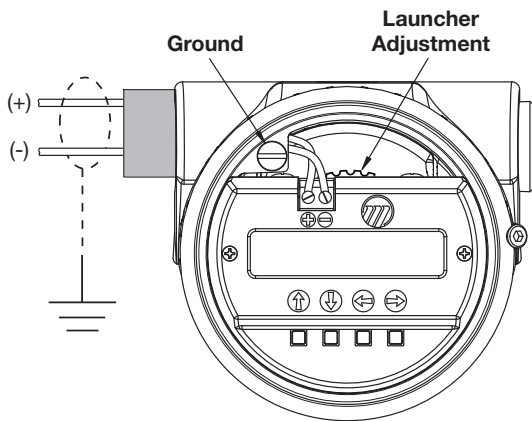

Figure 4

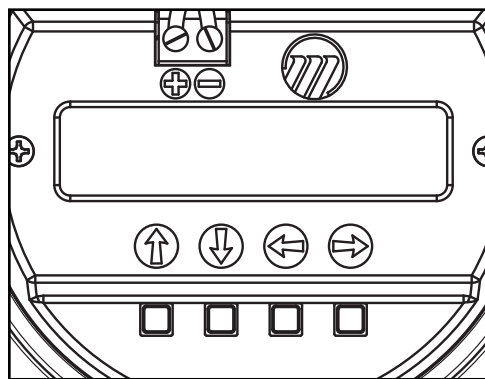

Figure 5

1. Power-up the transmitter.  
During normal operation the display changes every 2 seconds to show one of the various measured values that can be chosen for display: Level, Volume, Distance, Echo Strength, %Output, Loop Current and Local Tag.
2. Remove the cover of the electronic compartment.
3. The Pushbuttons offer multiple forms of functionality for menu navigation and data entry. (See Section 2.6.3 for complete explanation)
  - ⬆ UP arrow moves up through menu or increases displayed value
  - ⬇ DOWN arrow moves down through menu or decreases displayed value
  - ⬅ BACK arrow exits a branch of the menu or exits without accepting entered value
  - ➡ ENTER arrow enters a branch of the menu or accepts entered value

If a **PASSWORD** is requested, enter it now. The Default=0 (no password necessary).

The following configuration entries are the minimum required for configuration. The default password is 0 (no password necessary).

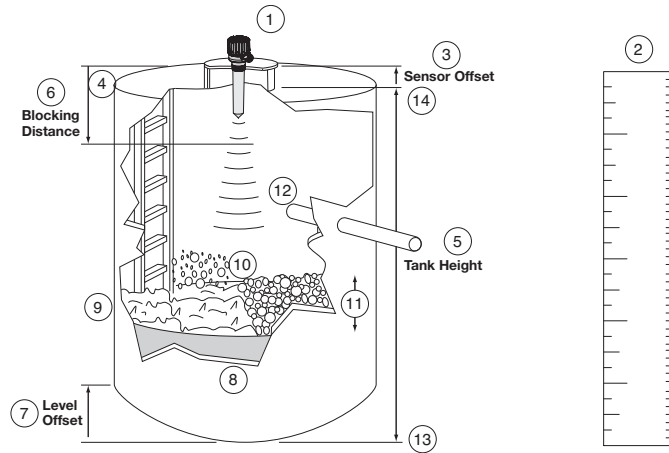

Figure 6

- |   |                       |   |    |                         |  |
|---|-----------------------|---|----|-------------------------|--|
| 1 | Measure Type          | Select if <b>Level</b> or <b>Level &amp; Volume</b>   | 8  | Dielectric (select)     | Select the proper <b>Dielectric</b> range for the process medium.  |
| 2 | Level Units (select)  | Select the <b>Units</b> of measure for the display (cm, inches, meters, feet).  | 9  | Turbulence (select)     | Select the value of <b>Turbulence</b> that corresponds to the application.   |
| 3 | Sensor Offset<br>xxxx | Enter the <b>Sensor Offset</b> value; the distance from the top of the vessel to the Sensor Reference point (bottom of an NPT thread, top of a BSP thread, face of a flange). | 10 | Foam (select)           | Select the <b>Foam</b> value that corresponds to the application.  |
| 4 | Tank Top (select)     | Select the type of <b>Tank Top</b> ; choices are Flat, Horizontal cylinder, Dome, Irregular, or Other (nonmetallic).  | 11 | Rate of Change (select) | Select the <b>Rate of Change</b> value that corresponds to the maximum rate the level will rise or fall.   |
| 5 | Tank Height<br>xxxx   | Enter the exact <b>Tank Height</b> ; inaccurate values will create inaccurate level readings.   | 12 | Echo Profile            | Examine the list of reflections detected by the transmitter to ensure the actual level reflection is present. It may be necessary to rotate the launcher for optimal performance. Run the <b>Echo Rejection</b> routine by choosing the correct LEVEL thereby cancelling all false reflections in the vessel; ideally with tank empty. |
| 6 | Blocking Dist<br>xxxx | Enter the <b>Blocking Distance</b> ; the distance close to the antenna where measurement is unreliable. Minimum value = 15" (375 mm) as measured from the process connection. | 13 | Set 4mA<br>xx.x         | Enter the minimum level value (0%) for the 4 mA point.   |
| 7 | Level Offset<br>xxx.x | Enter the <b>Level Offset</b> ; the distance at the bottom of the vessel where measurement may be unreliable due to heating coils, irregular bottom, etc.                     | 14 | Set 20mA<br>xx.x        | Enter the maximum level (100%) for the 20 mA point.  |

---

## 2.0 Complete Installation

This section provides detailed procedures for properly installing, configuring, and, as needed, troubleshooting the R82 Radar Level Transmitter.

### 2.1 Unpacking

Unpack the instrument carefully. Make sure all components have been removed from the packing material. Check all the contents against the packing slip and report any discrepancies to the factory.

Before proceeding with the installation, do the following:

- Inspect all components for damage. Report any damage to the carrier within 24 hours.
- Make sure the nameplate model number on the transmitter agree with the packing slip and purchase order.
- Record the model and serial numbers for future reference when ordering parts.

### 2.2 Electrostatic Discharge (ESD) Handling Procedure

Magnetrol's electronic instruments are manufactured to the highest quality standards. These instruments use electronic components that may be damaged by static electricity present in most work environments.

The following steps are recommended to reduce the risk of component failure due to electrostatic discharge.

- Ship and store circuit boards in anti-static bags. If an anti-static bag is not available, wrap the board in aluminum foil. Do not place boards on foam packing materials.
- Use a grounding wrist strap when installing and removing circuit boards. A grounded workstation is recommended.
- Handle circuit boards only by the edges. Do not touch components or connector pins.
- Make sure that all electrical connections are completely made and none are partial or floating. Ground all equipment to a good, earth ground.

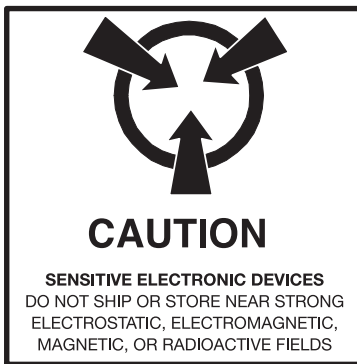

## 2.3 Before You Begin

### 2.3.1 Site Preparation

Each R82 Radar transmitter is built to match the physical specifications of the required installation. Make sure the antenna connection is correct for the threaded or flanged mounting on the vessel or tank where the transmitter will be placed. See Mounting, Section 2.4.

Make sure that the wiring between the power supply and Radar transmitter are complete and correct for the type of installation.

When installing the Radar transmitter in a general purpose or hazardous area, all local, state, and federal regulations and guidelines must be observed. See Wiring, Section 2.5.

### 2.3.2 Equipment and Tools

No special tools are needed. The following items are recommended:

- Threaded antenna and transmitter . . . . . 2" (50 mm)
- Flat-blade screwdriver
- Digital multimeter or volt/ammeter . . . . . Optional
- 24 VDC (23 mA) power supply. . . . . Optional

### 2.3.3 Operational Considerations

Radar applications are characterized by three basic conditions; Dielectric, Distance (measuring range) and Disturbances (turbulence, foam, false targets, multiple reflections and rate of change).

#### 2.3.3.1 Maximum Distance

The chart at left shows the maximum measuring range (Distance) based on fundamental conditions of Dielectric, Distance and Turbulence. Maximum distance is calculated as Tank Height + Sensor Offset (see page 21). It is measured from the Sensor Reference Point (bottom of NPT thread, top of BSP thread or face of a flange).

#### 2.3.3.2 Minimum Distance

If the liquid level is allowed onto the antenna, noise and media build-up drastically decrease reliable measurement. Liquid should not be allowed closer than 15 inches (380 mm) from the bottom of the antenna mounting threads (or face of sanitary flange). The distance from the end of the antenna varies depending on antenna chosen. See Figure 8.

**MAXIMUM DISTANCE** feet (meters)

Dielectric	Turbulence	R82
1.7-3.0	None	26 (8.0)
	Light, < 0.5"	21 (6.4)
	Moderate, < 1.0"	14 (4.3)
	Heavy, > 1.0"	7 (2.1)
3.0-10.0	None	33 (10.1)
	Light, < 0.5"	26 (7.9)
	Moderate, < 1.0"	19 (5.8)
	Heavy, > 1.0"	12 (3.7)
10.0-100	None	40 (12)
	Light, < 0.5"	32 (9.8)
	Moderate, < 1.0"	24 (7.3)
	Heavy, > 1.0"	17 (5.2)

Figure 7



- Foam can either absorb or reflect the microwave energy depending upon the depth, dielectric, density and wall thickness of the bubbles. Due to typical variations in the amount (depth) of foam, it is impossible to quantify performance. It may be possible to receive most, some or none of the transmitted energy.
- Extremely high liquid levels (Overflow) conditions when liquid very near the antenna (above the Blocking Distance) can cause erroneous readings and measurement failure.

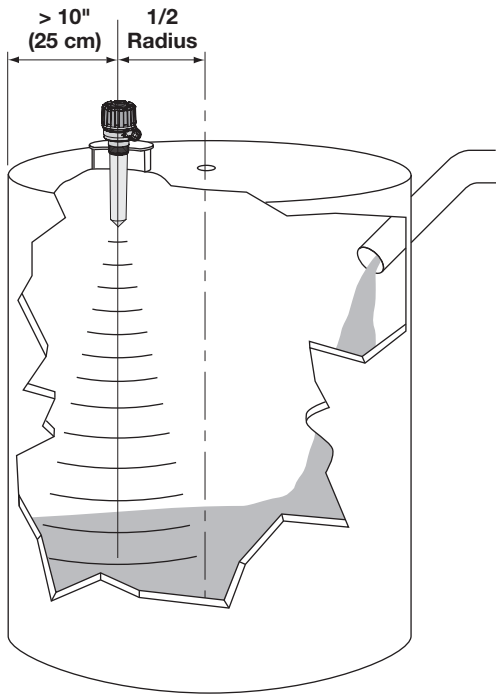
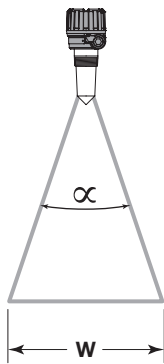

Figure 10



Distance		Beam Spread	
Feet	Meters	Feet	Meters
10	3	2.5	0.74
20	6	4.9	1.47
30	9	7.4	2.21
40	12	9.8	2.95

Figure 11

## 2.4 Mounting

The R82 Radar transmitter can be mounted to a vessel using a variety of process connections. Generally, either a threaded or flanged connection is used.

### 2.4.1 Installing the Antenna

Before installing, make sure:

- Process temperature, pressure, dielectric, turbulence and distance are within the antenna specifications for the installation.
- End of antenna is protected from bending or breaking.
- Insulating material is not placed around any part of the Radar transmitter including the antenna flange.
- Antenna is being mounted in the optimal location. See following sections: Location, Beam Angle, Obstructions and Nozzles for specific information.

#### 2.4.1.1 Location

Ideally, the Radar transmitter should be mounted providing an unobstructed signal path to the liquid surface where it should illuminate (with microwave energy) the largest, possible surface area. See Section 2.4.1.2, Beam Angle. Unavoidable obstacles will produce reflections that must be minimized during field configuration. See Section 2.6.5.1, Target Rejection. Mount in a location equal to  $\frac{1}{2}$  the radius of tank top. Do not mount in center of vessel nor closer than 10" (25 cm) from the tank wall.

#### 2.4.1.2 Beam Angle

Ideally, the beam pattern should illuminate the maximum liquid surface with a minimum striking other objects in the vessel including the tank wall.

### 2.4.1.3 Obstructions

Almost any object that falls within the beam pattern will cause reflections that may be misinterpreted as a false liquid level. Although Model R82 has a powerful Echo Rejection routine, all possible precautions should be taken to minimize false target reflections with proper installation and orientation. See Figure 12.

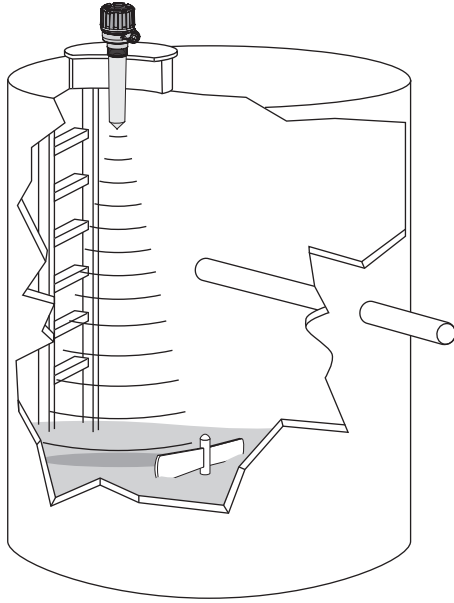

**Figure 12**  
**Avoiding Obstructions**

### 2.4.1.4 Nozzles

Improper installation in a nozzle creates “ringing” which will adversely affect measurement. Two Antenna extension lengths are offered to allow the R82 transmitter to work reliably in a variety of nozzles.

The Minimum Blocking Distance of 15" (380 mm) is always measured from the bottom of the threads or face of the flange. The related distance as measured from the end of the antenna varies depending on the antenna extension chosen. See Figure 13.

The narrow beam width of the 26 GHz, R82 does allow mounting so that the antenna can be recessed inside the nozzle. Optimally, the recessed dimension should never exceed **2× the nozzle diameter**. See Figure 13

NOTE: If the antenna is recessed in a nozzle it is mandatory that Echo Rejection is run to eliminate any possibility of false reflections.

### Maximum Recess ( $m$ ) is $2 \times$ Nozzle Diameter ( $d$ )

(example: 2" diameter nozzle)

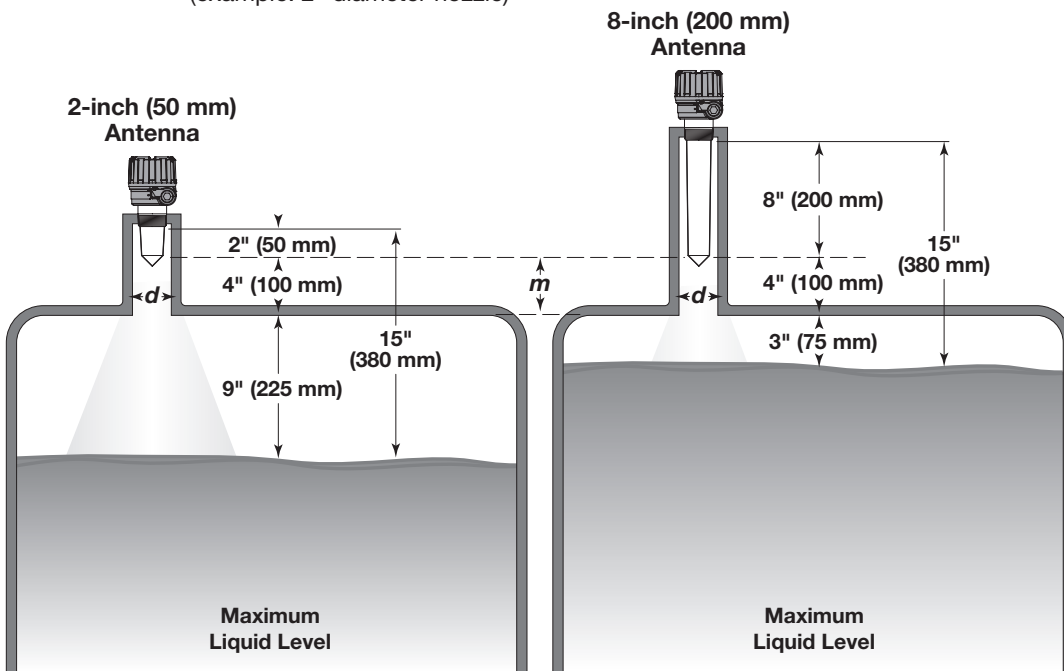

**Figure 13**

**Using nozzle height to maximize useable tank space**

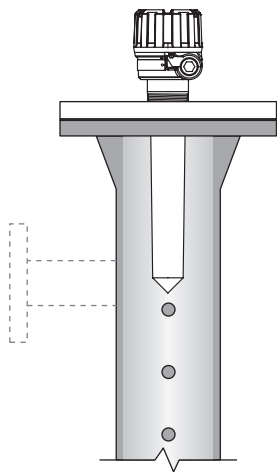
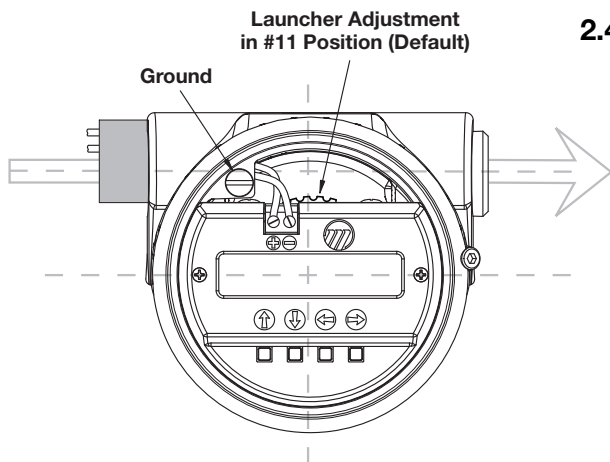

**Figure 14**  
**R82 Mounted in Stillwell (Bridle)**

### 2.4.1.5 Stillwells

The R82 can be mounted in a stillwell but certain considerations should be given:

- Metal stillwells only: 2" (50 mm) Sched 40 max.
- Diameter must be consistent throughout length; no reducers.
- Stillwell length must cover complete range of measurement (i.e., liquid must be in stillwell).
- Welds should be smooth.
- Vents: holes <0.125" diameter, slots <0.125" width.
- If an isolation valve is used, it must be a full port ball valve with an I.D. equal to the pipe diameter.
- Bridles/Bypass Installations: The launcher should be rotated 90° from process connections.
- Configuration must include an entry for PIPE I.D. See Section 2.6.6.2, Item 34- PIPE I.D.



**Figure 15**  
**Launcher Adjustment in #11 Position (default)**

### 2.4.2 Installing the Transmitter

Install the Transmitter with its integral antenna by threading into the vessel. **DO NOT OVERTIGHTEN** as this may cause damage to the plastic threads.

- Do not place insulating material around any part of the radar transmitter including the antenna flange.
- Installation for NEMA 6P/IP 68: the transmitter can be installed to allow for temporary submergence to 6.5 ft. (2m) for 24 hours:
  - use TFE paste to seal conduit entries or IP 68 cable glands
  - Do not overtighten plastic housing cover; O-ring develops water-tight seal without excessive tightening

#### 2.4.2.1 Orientation

The R82 transmitter utilizes a linearly polarized, microwave beam that can be rotated to improve its performance. Proper orientation can minimize unwanted reflections, decrease sidewall reflections (multipath) and maximize direct reflections from the liquid surface.

The internal launcher mechanism can be turned to optimize performance. The launcher has index marks numbered 1–18 (representing 10–180 degrees). The polarization pattern is parallel to the transmitter display when the adjustment mechanism is in the #11 position (factory default). See Figures 15 and 16.

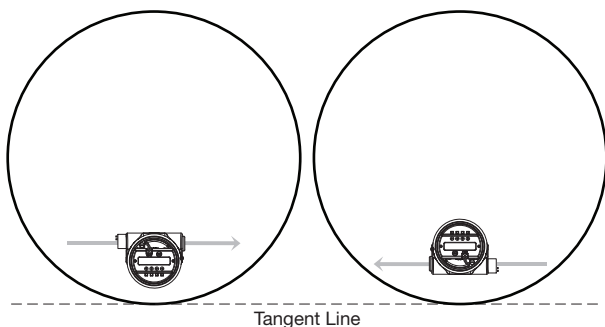

**Figure 16**  
**Polarization Pattern**

### 2.4.2.2 Initial Installation

Ideally, the transmitter should be mounted half the radius from the tank wall. In a typical vertical tank, the Launcher should be adjusted so the polarization pattern is parallel to a line tangent to the nearest tank wall. See Figure 16.

Rotate the internal Launcher adjustment to achieve the correct Polarization position. Remember each notch on the adjustment wheel is 10 degrees of rotation. See Figure 17.

For horizontal cylindrical vessels, aim beam down the long axis of the vessel. Do not optimize the Echo Strength at one level in the vessel.

A transmitter mounted within 10" (25 cm) of a tank wall may demand orientation adjustments to limit multipath and optimize performance. See Section 2.4.2.3, Poor Echo Strength.

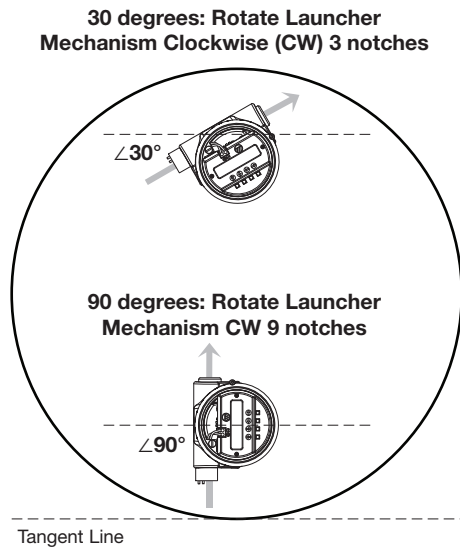

**Figure 17**  
Examples of Launcher Orientation Adjustments

### 2.4.2.3 Poor Echo Strength

Poor Echo Strength has many potential causes. Following are two initial areas for investigation.

**Launcher Orientation:** Initial launcher orientation is always parallel to tangent of the tank circumference (see Sections 2.4.2.1 & 2.4.2.2). In tall vessels and when antenna is mounted close to the tank wall, improvement in Echo Strength may be attained by rotating the launcher to 90 degrees.

**Signal Loss:** If the Level signal is lost repeatedly at a specific point in the vessel, it is usually a symptom that multipath (side-wall reflections) are causing cancellation by returning to the transmitter exactly 180° out of phase with the Level signal. Utilize the following procedure:

- Go to transmitter screen #5 which shows both Level and Echo Strength.
- Bring the Level up (or down) to the exact point where the signal is repeatedly lost. Monitor the Echo Strength this point is being approached. The Echo Strength will degrade to a low point before it begins to increase.
- At the poorest Echo Strength slowly rotate the launcher 1–2 notches. Allow the unit to stabilize for approximately one minute. Repeat this process until the Echo Strength is optimized.

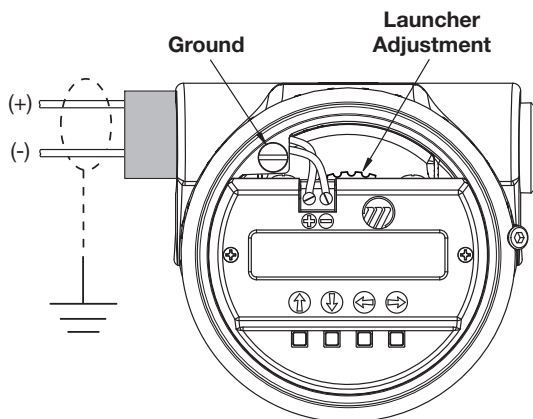

**Figure 18**  
Internal Launcher Adjustment

## 2.5 Wiring

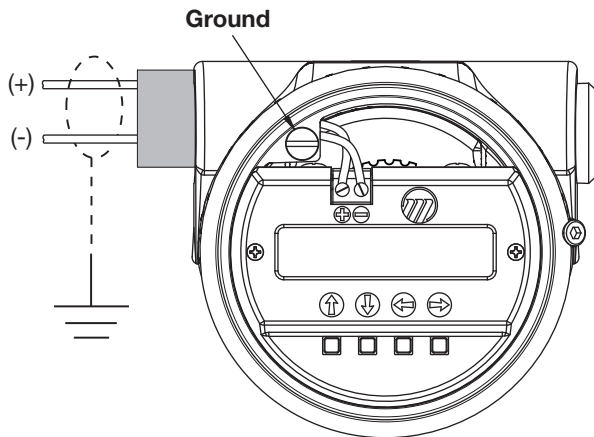

**Figure 19**  
**Wiring the Transmitter**

**Caution:** The R82 Radar transmitter operates at voltages of 16–36 VDC (GP) and 16-28.6 VDC (IS). Higher voltage will damage the transmitter.

**NOTES:**

- If sufficient supply voltage is suspect, use the R82 Low Voltage check (Section 2.6.6.1, #37: Test 4-20 Loop).
- For ATEX installation guidelines refer to bulletin BE 58-610.

Wiring between the power supply and the Radar transmitter should be made using 18–22 AWG shielded twisted pair instrument cable. Within the transmitter enclosure, connections are made to the terminal strip and the ground connections. Trim excess wiring to minimize clutter, noise issues and allow access to Launcher adjustment. See Figure 19. The directions for wiring the Radar transmitter depend on the application:

- General Purpose or Non-incendive (CI I, Div. 2)
- Intrinsically Safe

### 2.5.1 General Purpose or Non-incendive (CI I, Div. 2)

A general purpose installation does not have flammable media present. Areas rated non-incendive (CI I, Div. 2) have flammable media present only under abnormal conditions. No special electrical connections are required. If flammable media is contained in the vessel, the transmitter must be installed per CI I, Div. 1 standards of area classification.

**To install General Purpose or Non-incendive wiring:**

1. Remove the cover to the wiring compartment of the transmitter. Install the conduit plug in the unused opening.
2. Install a conduit fitting and pull the supply wires.
3. Connect shield to an earth ground at power supply and leave floating at the transmitter.
4. Connect an earth ground wire to the nearest green ground screw per local electrical code (not shown in illustration).
5. Connect the positive supply wire to the (+) terminal and the negative supply wire to the (-) terminal.
6. Seal conduit to prevent ingress of moisture.
7. Replace cover of the transmitter.

### 2.5.2 Intrinsically Safe

**(PENDING AGENCY APPROVAL)** An intrinsically safe (IS) installation potentially has flammable media present. An approved IS barrier must be installed in the non-hazardous (safe) area. **To install Intrinsically Safe wiring:**

1. Make sure the IS barrier is properly installed in the safe area (refer to local plant or facility procedures). Complete the wiring from the barrier to the Radar transmitter.
2. Remove the cover of the transmitter. Install the conduit plug in the unused opening.
3. Install a conduit fitting and pull the supply wires.
4. Connect shield to an earth ground at power supply and leave floating at the transmitter.

5. Connect an earth ground wire to the nearest green ground screw (not shown in illustration).
6. Connect the positive supply wire to the (+) terminal and the negative supply wire to the (-) terminal.
7. Replace the cover of the transmitter.

## 2.6 Configuring the Transmitter

The Radar transmitter comes factory-calibrated and can be configured in minutes for specific applications.

Before configuring the transmitter, collect the operating parameters information. Then, power-up the transmitter on the bench and follow through the step-by-step procedures for the menu-driven transmitter display. Information on configuring the transmitter using a HART communicator is given in Configuration Using HART (Section 2.7).

### 2.6.1 Operating Parameters

Some key information is needed to configure the Radar transmitter. If necessary, complete the configuration information table in Section 1.1.2.

### 2.6.2 Setting Up for Shop Configuration

The Radar transmitter can be configured at a test bench by connecting a 24 VDC power supply directly to the transmitter terminals. The connections are illustrated in the accompanying diagrams. An optional digital multimeter is shown if current measurements are desired.

When using a HART communicator for configuration, a minimum 250  $\Omega$  line load resistance is required. See the HART communicator manual for more information.

### 2.6.3 Transmitter Display and Keypad

The R82 transmitter has a local user interface consisting of a 2-line  $\times$  16-character liquid-crystal display (LCD) and 4-push-button keypad. All transmitter measurement data and configuration information is shown in the LCD.

The transmitter default display is the measurement screen. It cycles every 2 seconds to display \*STATUS\*, \*LEVEL\*, \*ECHO STRENGTH\*, \*%OUTPUT\*, \*LOOP CURRENT\* and \*LOCAL TAG\* information. The transmitter defaults to this display after 5 minutes if no keystrokes are sensed. You can also access each of these screens individually. The display will not return to the default screen if left in one of these screens. For example, the device can be left to display only LEVEL indefinitely if left in this screen.

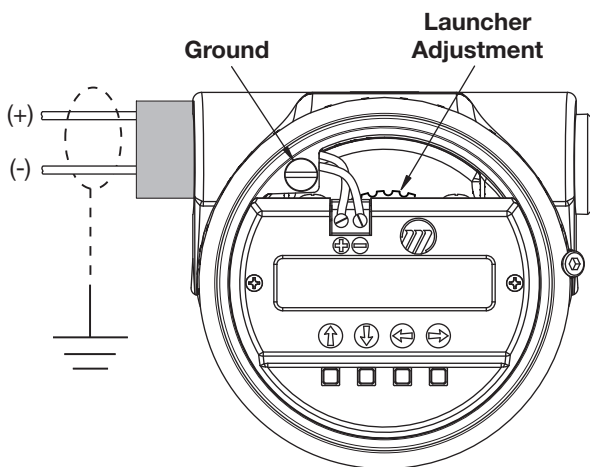





**Figure 20**  
**Display and Keypad**

## 2.6.4 Menu Traversal and Data Entry

The four push buttons offer various forms of functionality for navigation and data entry (i.e., Navigation, Data Selection, etc.).

### 2.6.4.1 Navigating Menu

Push button		Keystroke Action
	Up	Moves to the previous item in the menu branch
	Down	Moves to the next item in the menu branch
	Back	Moves back one level to the previous higher branch item
	Enter	Enters into the lower level branch or switches to the entry mode

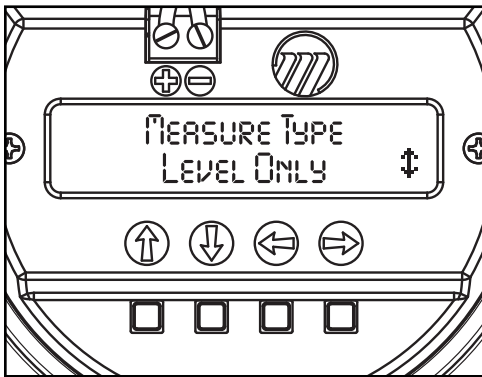

Figure 21

### 2.6.4.2 Data Selection

Use this method for selecting configuration data from a specific list. An arrow will appear when in the Data Selection mode. See Figure 21.

Use the following procedure:

- UP an DOWN arrows to navigate the main menu
- ENTER arrow to allow modification of selection
- UP an DOWN arrows to choose new selection
- ENTER arrow to confirm selection
- Use BACK (Escape) key at any time to abort the procedure and escape to previous branch item.

### 2.6.4.3 Entering Numeric Data Using Digit Entry

Use this method to input numeric data, e.g., Sensor Offset.

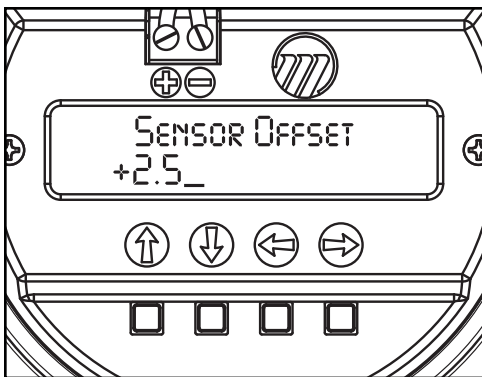





Figure 22

NOTES: All numeric values are left-justified, and new values are entered from left to right. A decimal point can be entered after the first digit is entered, such that .9 is entered as 0.9.

Some configuration items can have a negative value. In this case, the leftmost position is reversed for the sign (either "-" for a negative value, or "+" for a positive value).

Push button		Keystroke Action
	Up	Moves up to the next highest digit (0,1,2,3,....,9). If held down the digits scroll until the push button is released.
	Down	Moves down to the next lowest digit (9,8,7,6,....,0). If held down the digits scroll until the push button is released.
	Back	Moves the cursor to the left and deletes a digit. If the cursor is already at the leftmost position, then the screen is exited without changing the previously saved value.
	Enter	Moves the cursor to the right. If the cursor is located at a blank character position, the new value is saved.

#### 2.6.4.4 Entering Numeric Data Using Increment/Decrement

Use this method to input the following data: Damping, Echo Loss Delay, Trim Level, Trim 4 mA, Trim 20 mA, Test 4-20 Loop and HART Poll Addr.

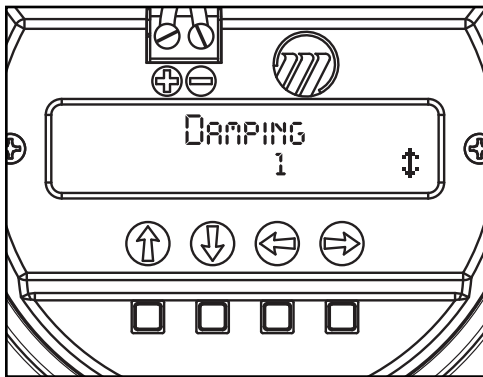

Figure 23

Push button		Keystroke Action
⬆	Up	Increments the displayed value. If held down the digits scroll until the push button is released. Depending on which screen is being revised, the increment amount may increase by a factor of 10 after the value has been incremented 10 times.
⬇	Down	Decrements the displayed value. If held down the digits scroll until the push button is released. Depending on which screen is being revised, the decrement amount may increase by a factor of 10 after the value has been decremented 10 times.
⬅	Back	Returns to the previous menu without changing the original value, which is immediately redisplayed.
➡	Enter	Accepts the displayed value and returns to the previous menu.

#### 2.6.4.5 Entering Character Data

This method is used for entering alphanumeric characters, e.g., Input Local Tag.

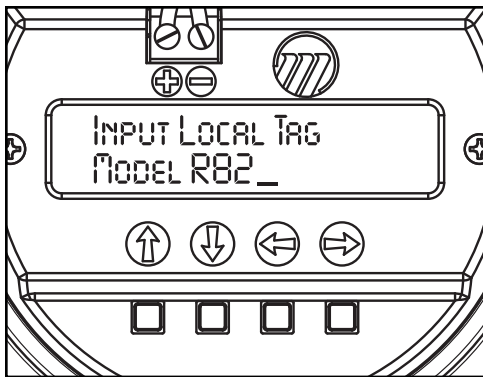

Figure 24

Push button		Keystroke Action
⬆	Up	Moves to the previous character (Z,Y,X,W). If held down the characters scroll until the push button is released.
⬇	Down	Moves to the next item character (A,B,C,D). If held down the characters scroll until the push button is released.
⬅	Back	Moves the cursor back to the left. If the cursor is already at the leftmost position, then the screen is exited without changing the original tag characters.
➡	Enter	Moves the cursor forward to the right. If the cursor is at the rightmost position, then the new tag is saved.

---

## 2.6.5 Password Protection (Default = 0)

The Radar transmitter is password protected to restrict access to certain portions of the menu structure that affect the operation of the system. The password can be changed to any numerical value up to 255. The password is required whenever configuration values are changed.

The default password installed in the transmitter at the factory is 0 (password disabled). The last step in the configuration menu provides the option to enter a new password. If 0 is entered as a password, the transmitter is no longer password protected and any value in the menu can be altered (except diagnostic values) without entering a confirming password.

**NOTE:** If the password is not known, the menu item New Password (Section 2.6.6.1, item #39) displays an encrypted value representing the present password. Call the factory with this encrypted value to determine the actual password.

## 2.6.6 Menu: Step-By-Step Procedure

The following table provides a complete explanation of the software menus displayed by the Radar transmitter. Use this table as a step-by-step guide to configure the transmitter.

The first column presents the menus shown on the transmitter display. The displays are in the order they would appear if the arrow keys were used to scroll through the menu. The numbers are not shown on the display. They are provided as a reference only.

The second column provides the actions to take when configuring the transmitter. Additional information or an explanation of an action is given in the third column.

The following drawings are provided as reference for the configuration procedure.

Use of the included PACTware™ PC program is highly recommended and invaluable for troubleshooting and advanced calibration. A HART RS232 or USB modem (purchased separately) is required. See Magnetrol PACTware™ bulletin 59-101.

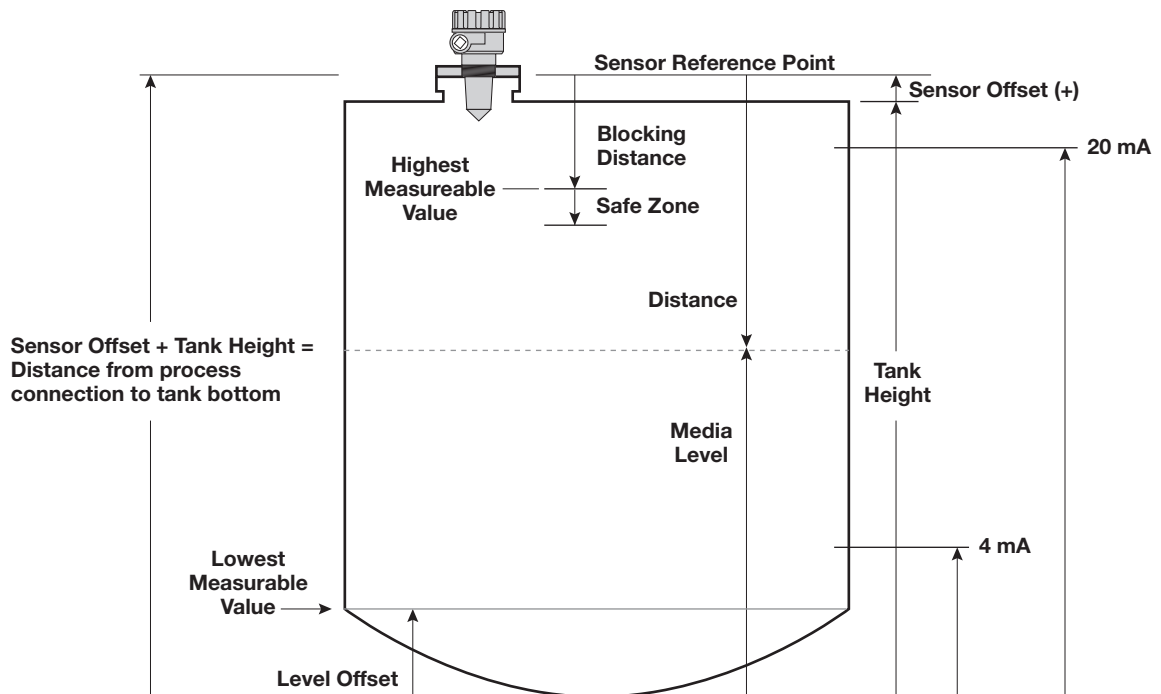

Figure 25

### 2.6.6.1 Radar Transmitter User Menu

Note: Press UP arrow 5 times to reach screen where menu language can be chosen.

	Display	Action	Comment
1	*Status* *Level* *Volume* *Distance* *Echo Str xx* *%Output* *Loop Current* *Local Tag*	Transmitter Display	Transmitter default display: Status, Level, Volume (if chosen) Echo Strength, % Output, Loop Current and Local Tag values advance every 2 seconds. All screens (except 2-8) default to this screen after 5 minutes of no keystrokes or if a Fault or Warning message is displayed.  Default display will also show the highest priority Fault or Warning. If more than one Fault or Warning exists they will be displayed in the History screen (#46) in chronological order.  To Add/Remove what information is shown in default display: <ul style="list-style-type: none"> <li>• Go to specific parameter in question (screens 2-8)</li> <li>• Press Enter</li> <li>• Choose On or Off</li> <li>• Press Enter to confirm</li> </ul>
2	Level xxx.x units	Transmitter Display	Transmitter displays Level measurement in chosen unit of measure.
3	Volume xxx.x units	Transmitter Display	Transmitter displays Volume measurement in chosen unit of measure (if chosen)
4	Distance xxx.x units	Transmitter Display	Transmitter displays Distance measurement in chosen unit of measure; measurement includes Sensor Offset value. This value may not represent reciprocal of Level if the liquid level is within the Blocking Distance or Level Offset where the Level value is clamped.
5	Echo Strength xx xxx.x units	Transmitter Display	Transmitter display showing Level and Echo Strength of signal reflection. Good values are 20-99.
6	% Output xx.x%	Transmitter Display	Transmitter displays % Output measurement derived from 20 mA span.
7	Loop Current xx.xx mA	Transmitter Display	Transmitter displays Loop Current value (mA).
8	Local Tag xxxxxxxxxxxx	Transmitter Display	Transmitter displays Local Tag information.
9	Measure Type (select)	Select Type of Measurement	Select Level Only or Level & Volume. Volume, Volume Units, Loop Control, and Strapping Table screens appear only when Level & Volume is selected. Note that the Volume screen is selected for rotation when Measure Type is set to Level & Volume and is deselected when Measure Type is set to Level Only.
10	Level Units (select)	Select Units of measure.	Select cm (xxxx), meters (xx.xx), inches (xxx.x), or feet (xx.xx). Allowable decimal position is controlled; four characters is maximum reading. Decimal position is controlled by Units and Tank Height
11	Volume Units (select)	Select Volume units of measure.	Select Liters (xxxx) or Gallons (xxxx).
12	Strapping Table (enter)	Enter Strapping Table information	Enter up to 20 pairs of data for Level and Volume.
13	Sensor Offset xx.x units	Enter the Sensor Offset value	Sensor Offset is the distance (+ or -) from the Sensor reference point (bottom of NPT thread or flange face, top of BSP thread) to the top of the tank.
14	Tank Top (select)	Enter the shape/type of tank top	Select the metallic tank top structure Flat, Horizontal Cylinder, Dome, Irregular, or Other (non-metallic).
15	Tank Height xxx.xx units	Enter the Tank Height.	Tank Height is distance from the bottom to the top of the tank.

	Display	Action	Comment
16	Blocking Distance (xxx.x)	Enter the Blocking Distance.	Blocking Distance defines an area near the antenna where reflections can not be measured effectively due to antenna ringing. It is measured from the Sensor Reference point. Default of 15" (375 mm) minimum distance from the process connection to the maximum level. Extend this value when necessary to block reflections from objects close to the antenna. Output will be held at value corresponding to Blocking Distance. Do not allow liquid into the Blocking Distance as false readings can result.
17	Level Offset (xxx.x units)	Enter the Level Offset.	Level Offset defines an area at the bottom of the vessel where reflections can not be measured effectively due to angled bottoms, heating coils, reflections from flat metal tank bottoms in low dielectric applications, etc. It is the distance from the bottom of the tank to the lowest valid level reading. Level reading will never be lower than Level Offset value.
18	Dielectric (select)	Enter the Dielectric range value.	1.7-3.0; 3.0-10.0; 10.0-100.0
19	Turbulence (select)	Select amount of Turbulence of the liquid.	None, Light, Medium, Heavy. Increase selection if Echo is often lost or Echo Strength is <20.
20	Foam (select)	Select amount of Foam.	None, Light, Medium, Heavy. Increase selection if Echo is often lost or Echo Strength is <20.
21	Rate of Change (select)	Select Rate of Change of the liquid.	Select the maximum rate of change of the level surface, rising or falling, in inches (cm)/minute; <5 (13), 5-20 (13-50), 20-60 (50-150), >60 (150)
22	Echo Profile	Press Enter to - Review all Echoes  - Run a new Echo Rejection Profile	<p>1.) Echo List Mode- Choose to review echoes in Distance or Level</p> <p>2.) Review all echoes using UP/DOWN arrows; listed in descending Level value</p> <p>3.) To run a new Echo Rejection Profile</p> <p>a.) Choose the echo that corresponds to the actual liquid level</p> <p>b.) Press ENTER and confirm a new Echo Rejection profile should be run. If necessary, Press ESCAPE to exit at any time.</p> <p>NOTES:</p> <ul style="list-style-type: none"> <li>- ECHO REJECTION should run with vessel at or near empty when all targets are exposed</li> <li>- Re-run this routine if initial calibration is done with significant liquid in vessel</li> <li>- The Echo Rejection profile will be disabled and this routine must be re-run if the following parameters are modified: SENSOR OFFSET, TANK HEIGHT, BLOCKING DISTANCE, DIELECTRIC, TURBULENCE, FOAM</li> <li>- The EchoRej Invalid message will be displayed if this algorithm is DISABLED due to a parameter change.</li> </ul> <p style="text-align: right;"><i>continued on next page</i></p>

	Display	Action	Comment
22	Echo Profile (cont.)	- Review an existing Echo Rejection Profile	<i>continued from previous page</i> 4.) Enter Level- use this entry to manually enter the correct level value Error messages: "Echo too Close" indicates the liquid is too close to the antenna. Liquid should not be closer than 30" (750 mm). "Echo too Strong" indicates an echo being rejected is too strong. a.) Ensure it is not the actual liquid level b.) Rotate the Launcher to minimize the echo 5.) Saved Echo Rejection Profile- a.) Enable or Disable an existing profile b.) Review Echoes from an existing profile c.) Review Level value where existing profile was run
23	Loop Control (select)	Select mode for Loop Control	Select Level or Volume.
24	4 mA Set Point (xxx.x units)	Enter the value for the 4 mA point.	During normal operation, mA value will clamp at boundary defined by the Level Offset value (refer to #17).
25	20 mA Set Point (xxx.x units)	Enter the value for the 20 mA point.	During normal operation, mA value will clamp at boundary defined by the Blocking Distance value (refer to #16).
26	Damping (xx sec)	Enter the Damping factor.	A damping factor (0-45) may be added to smooth a noisy display and/or output due to turbulence.
27	System Fault (select)	Select the System Fault value.	Select 3.6 mA, 22 mA or HOLD (last value).
28	Echo Loss Fault (select)	Select the Echo Loss Fault value.	Select 3.6 mA, 22 mA or HOLD (last value)
29	Echo Loss Delay (xxx sec)	Enter the value for the Echo Loss Delay.	Select a value 0-1000; 30 is default
30	Safe Zone Fault (select)	Select the Safe Zone Fault.	Safe Zone is a user-defined area just below the Blocking Distance. Set this Fault if it necessary to ensure safe, reliable high-level readings in critical applications. Choices are 3.6 mA, 22 mA, Latch 3.6 or Latch 22. If Latch 3.6 or Latch 22 is chosen, the loop current will remain in alarm until it is cleared by customer in SZ Latch below (refer to #32)
31	Safe Zone Height (xx.x units)	Enter a Safe Zone Distance.	Enter a distance value that develops a zone just below the Blocking Distance. At this point the unit will report a Safety Zone Fault (refer to #30) if the level rises into this area.
32	Safe Zone Alarm (Reset)	Clear Safe Zone Alarm	Clear a latched Safe Zone alarm.
33	Trim Level (xxx.x units)	Enter a Trim Level value	Trim Level is an offset value to be used to force the transmitter to output the proper Level. This should only be used after Tank Height and Sensor Offset have been confirmed as correct. -24 to +24 inches (-61 to +61 cm)
34	Pipe I.D. (xx.x units)	Enter Pipe I.D.	For measuring in a stillwell. Enter a value for inside diameter of the pipe ( <b>presently only 2" (50mm) is acceptable</b> ). Range of values 0, 3-20 inches (0, 40-500 mm). Value must be left as 0 if no standpipe/stillwell is present.
35	Trim 4 mA	Fine tune the 4mA point.	Attach a mA meter to the output. If the output does not equal 4.00 mA, adjust the value on the display until meter reads 4.00 mA. This is not for setting the 4mA point (refer to #24).

	<b>Display</b>	<b>Action</b>	<b>Comment</b>
36	Trim 20 mA	Fine tune the 20mA point.	Attach a mA meter to the output. If the output does not equal 20.00 mA, adjust the value on the display until meter reads 20.00 mA. This is not for setting the 20mA point (refer to #25).
37	Test 4-20 Loop (xx.xx mA)	Enter a mA Output value.	This screen serves two functions: 1.) Calibrate Loop: Enter mA output value to send a constant current. Present current will be returned upon exiting screen 2.) Check for sufficient loop voltage @20mA: a.) Drive current value to 4.00mA b.) Drive current value to >10mA c.) Press ENT; top line of display will show - (???) if done incorrectly - (OK) if sufficient VDC is calculated - (Low) if insufficient VDC is calculated d.) Bottom line of display will show calculated loop voltage at 20mA
38	Hart Poll Addr (xx)	Select HART Poll Address number.	Select HART Poll Address number. Select a HART Poll Address (0-15). Enter 0 for a single transmitter installation; enter 1-15 for multi-drop HART network.
39	New Password (enter)	Enter new Password.	Enter the desired Password value between 0 and 255; 0 = No Password. During normal operation an encrypted password is shown. Consult factory to decrypt this value, if necessary.
40	Language (select)	Select Language.	Select Language that will be displayed on the transmitter screen. English, Espanol, Deutsch and Francais.
41	Input Local Tag (enter)	Enter Local Tag.	Local Tag can be a maximum of 12 characters.
42	Magnetrol S/N	Transmitter Display	Shows Magnetrol Serial Number for reference.
43	Model R82 version	Transmitter Display	Base Model Number with Communication type (HT = HART) Firmware Version and Date
44	Factory Params	Enter to display Factory Parameters	Enter to display Factory Parameters. This section displays twenty-nine screens. The History screens are of particular importance to the user as they show a listing of chronological, diagnostic events, most recent first.

## 2.6.6.2 Radar Transmitter Factory Menu

	Display	Action	Comment
45	Factory Params	Select Enter to reveal Factory Parameters; Back to escape.	Review Factory parameters
46	History		Displays history of diagnostic information - Main screen displays active message - Press Enter to display chronological listing of diagnostic events - Use Up/Down arrows to view list of events - Press Enter when viewing an event to see its timing information - Press Up/Down arrows to view Occured or Duration NOTE: Times are measured from moment of power-up, displayed in seconds or tenths of an hour - Press Back to exit
47	Run Time	Display Run Time	Displays elapsed time since most recent power-up.
48	History Reset	Reset History	Press Enter to clear diagnostic information in History and reset Run Time to zero.
49	System Code	Displays System Code errors	Diagnostic, factory setting
50	Elec Temperature	Display Electrical Temperature	Displays current temperature on circuit board
51	Max Temperature	Display Max Temperature	Displays maximum temperature recorded for circuit board
52	Min Temperature	Display Min Temperature	Displays minimum temperature recorded for circuit board
53	VDC Chk Midpoint	None, do not adjust	Diagnostic factory setting
54	Antenna Mount	None, do not adjust	Diagnostic factory setting
55	Echo Profile	None, do not adjust	Diagnostic factory setting
56	Target Algorithm	None, do not adjust	Diagnostic factory setting
57	TVG Minimum	None, do not adjust	Diagnostic factory setting
58	TVG Maximum	None, do not adjust	Diagnostic factory setting
59	Peak Detect Ref	None, do not adjust	Diagnostic factory setting
60	Peak Detect Thresh	None, do not adjust	Diagnostic factory setting
61	Min Threshold	None, do not adjust	Diagnostic factory setting
62	# Run Average	None, do not adjust	Diagnostic factory setting
63	# Adap Average	None, do not adjust	Diagnostic factory setting
64	Scatter HiLimit	None, do not adjust	Diagnostic factory setting
65	Rate HiLimit	None, do not adjust	Diagnostic factory setting
66	Scatter Rate	None, do not adjust	Diagnostic factory setting
67	Lvl ROC Per Min	None, do not adjust	Diagnostic factory setting
68	Max ROC Per Min	None, do not adjust	Diagnostic factory setting
69	Max Distance Jump	None, do not adjust	Diagnostic factory setting
70	Boundary State	None, do not adjust	Diagnostic factory setting
71	EmptyState Delay	None, do not adjust	Diagnostic factory setting
72	NSPValue	None, do not adjust	Diagnostic factory setting
73	HART Device ID	None, do not adjust	Diagnostic factory setting
74	Factory Calib	None, do not adjust	Diagnostic factory setting
75	Window	None, do not adjust	Diagnostic factory setting
76	Target Distance	None, do not adjust	Diagnostic factory setting
77	Conversion Factor	None, do not adjust	Diagnostic factory setting
78	Scale Offset	None, do not adjust	Diagnostic factory setting
79	System Gain	None, do not adjust	Diagnostic factory setting

## 2.6.7 HART Menu

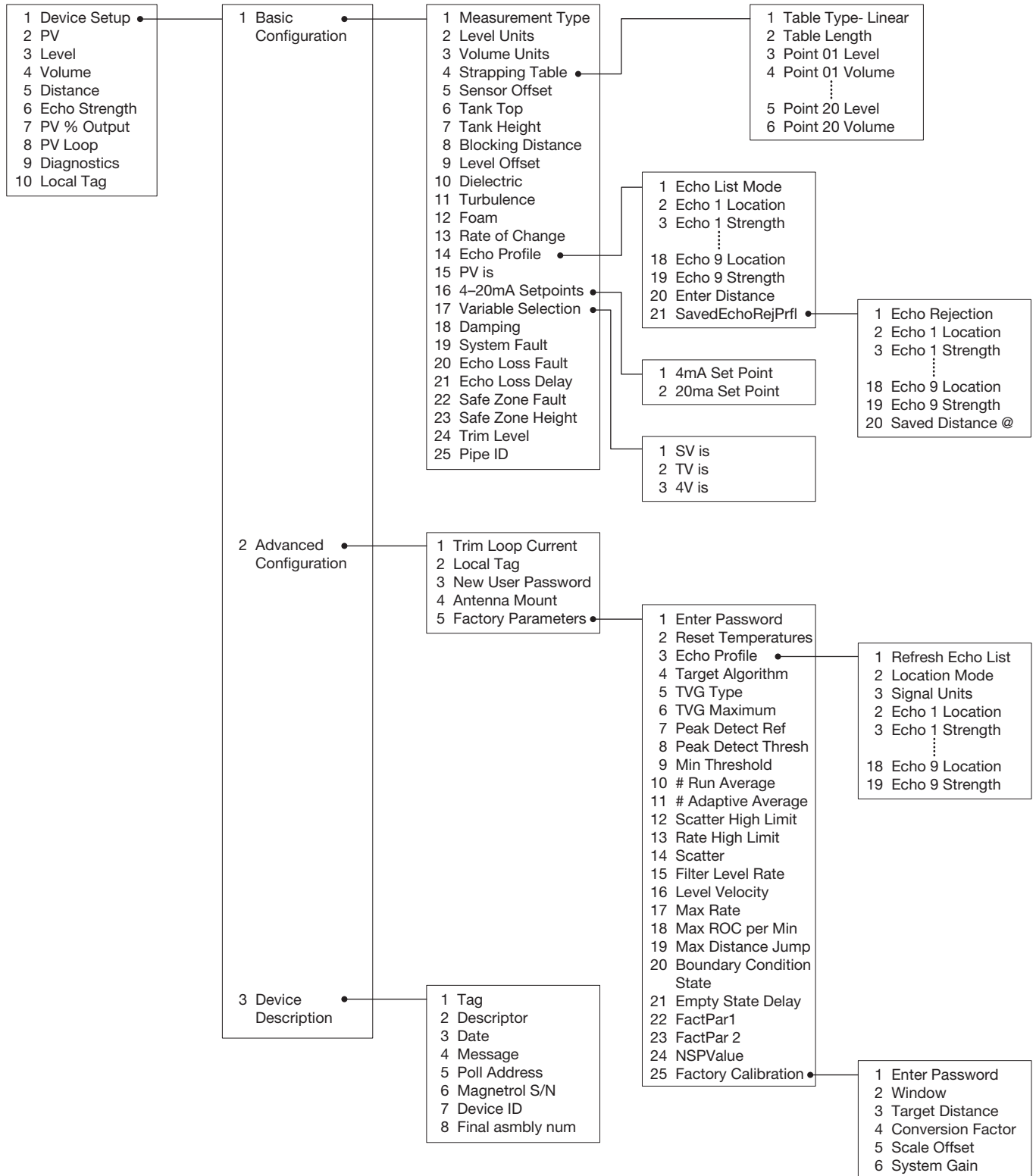

## 2.6.7 HART Menu (cont.)

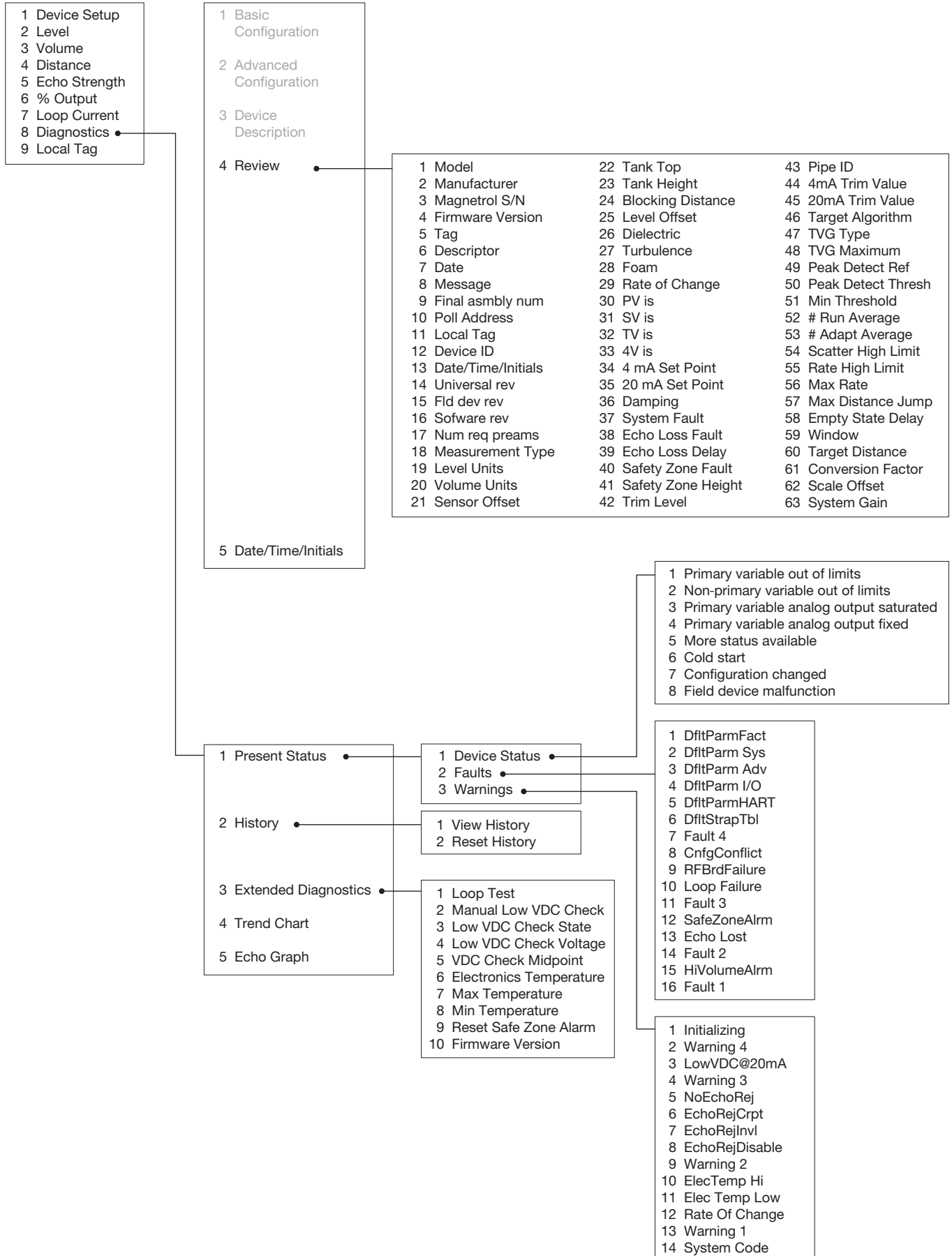

## 3.0 Reference Information

This section presents an overview of the operation of the Model R82 Radar Level Transmitter, information on troubleshooting, common problems, listings of agency approvals, lists of replacement and recommended spare parts, and detailed physical, functional and performance specifications.

## 3.1 Description

The Model R82 is a two-wire, 24 VDC level transmitter based on the concept of pulse burst radar operating at 26GHz. The electronics are mounted in a metal or plastic housing with an innovative, internal launcher orientation mechanism.

## 3.2 Theory of Operation

### 3.2.1 Pulse Burst Radar

The Model R82 is a top-mounted, downward-looking pulse burst radar operating at 26 GHz. Unlike true pulse devices that transmit a single, sharp (fast rise-time) waveform of wide-band energy, the R82 emits short bursts of 26 GHz energy and measures the transit time of the signal reflected off the liquid surface. Distance is calculated utilizing the equation  $\text{Distance} = C \times \text{Transit time} / 2$ , then developing the Level value by factoring in Tank Height and Sensor Offset information. The exact reference point for distance and level calculations is the Sensor Reference Point—bottom of an NPT thread, top of a BSP thread or face of a flange.

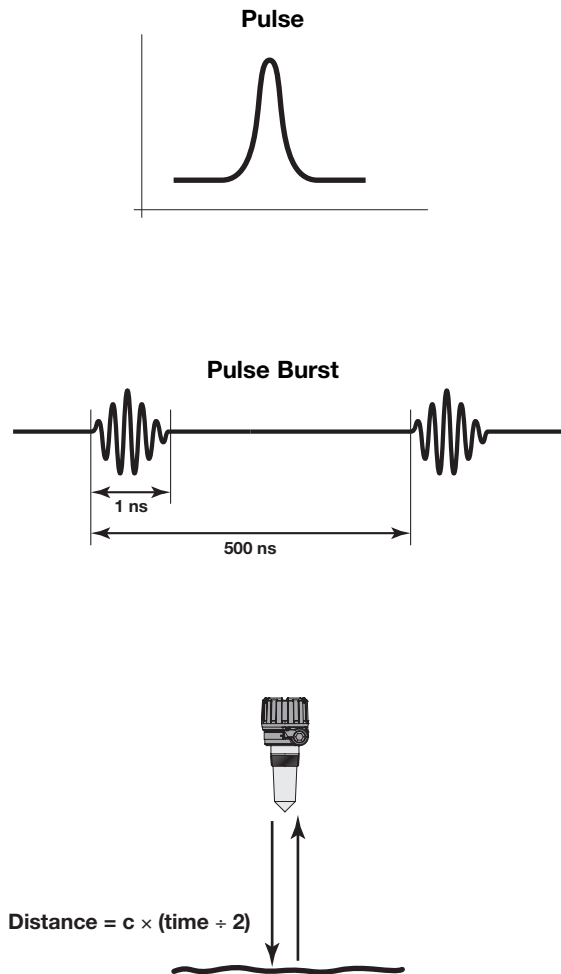

Figure 26

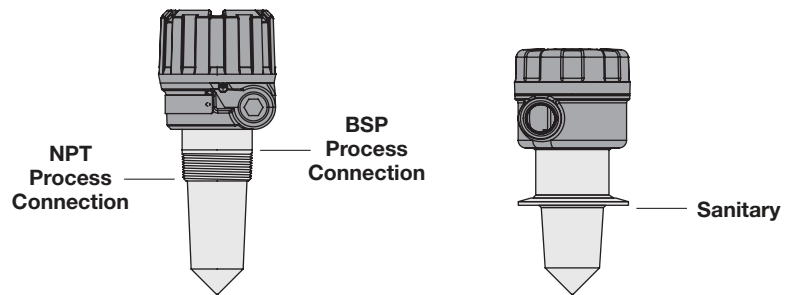

Figure 27  
Sensor Reference Point

The exact level measurement is extracted from false echo reflections and other background noise via the use of sophisticated signal processing. The new R82 circuitry is extremely energy efficient so no duty cycling is necessary to accomplish effective measurement. For this reason, the R82 can track high rates of change that were heretofore impossible with existing loop-powered radar transmitters.

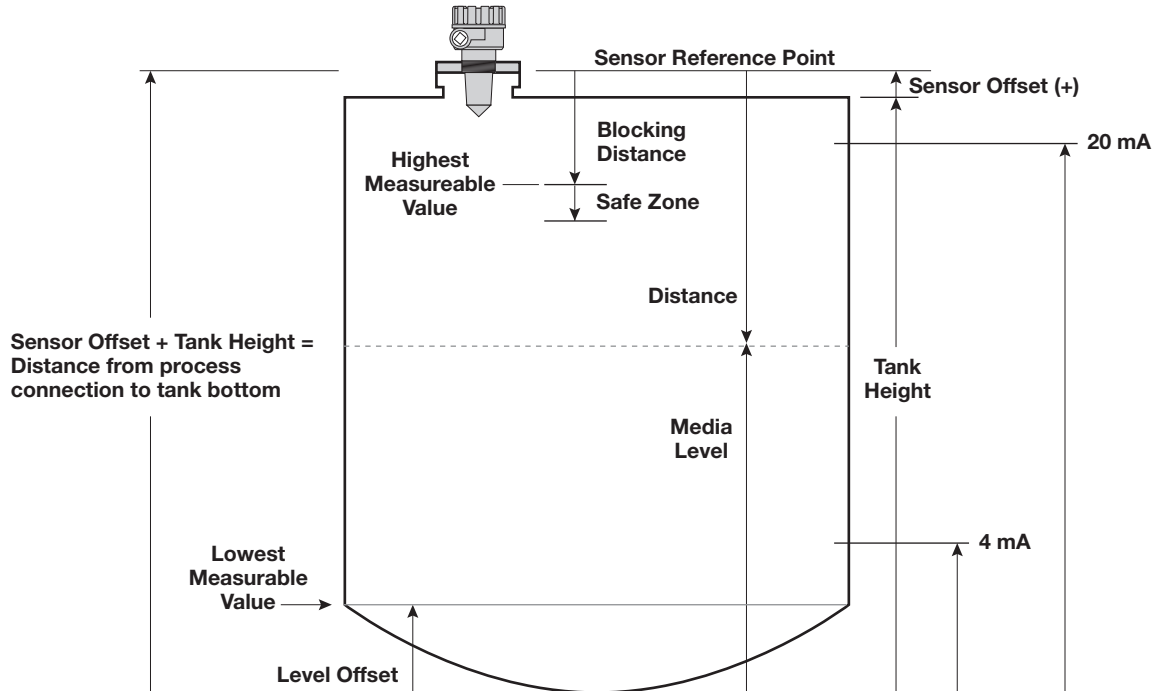

Figure 28

### 3.2.2 Equivalent Time Sampling

ETS, or Equivalent Time Sampling, is used to measure the high speed, low power EM (electromagnetic) energy. ETS is a critical key in the application of Radar to vessel level measurement technology. The high speed electromagnetic energy (1 ft/nS) is difficult to measure over short distances and at the resolution required in the process industry. ETS captures the EM signals in real time (nanoseconds) and reconstructs them in equivalent time (milliseconds), which is much easier to measure with today's technology.

ETS is accomplished by scanning the tank to collect thousands of samples. The round-trip event on a 40-foot (12.3m) tank takes only 82 nanoseconds in real time. After it is reconstructed in equivalent time it measures 135 milliseconds.

### 3.3 Troubleshooting

The Model R82 transmitter is designed and engineered for trouble-free operation over a wide range of operating conditions. Common transmitter problems are discussed in terms of their symptoms and recommended corrective actions.

**WARNING!** Explosion hazard. Do not remove covers unless power has been switched off or the area is known to be non-hazardous.

Use of the included PACTware™ PC program is highly recommended and invaluable for troubleshooting and advanced calibration. A HART RS232 or USB modem (purchased separately) is required. See Magnetrol PACTware™ bulletin 59-101.

#### 3.3.1 Troubleshooting System Problems

Symptom	Problem	Solution
Level reading drops out at a repeatable position in the vessel	Multipath is cancelling good level signal	Orient launcher to reduce multipath; turn launcher 10–20 degrees (1–2 index marks) at a time until multipath at this point disappears. Refer to Section 2.4.2.3
Level reading locked onto a value that is not correct	Measurement engine finding a reflection it believes is level signal	1. Is high dielectric ( $\epsilon > 10$ ) foam present? 2. Run Echo Rejection routine with Level below this point (or with Empty tank) to eliminate false echoes
LEVEL, % Output and LOOP values are all inaccurate	Basic configuration data questionable	1. Check validity of all configuration data 2. Check DISTANCE value of device against manually measured distance
LEVEL readings are repeatable but consistently high (or low) from actual by a fixed amount	Configuration data does not accurately match tank dimensions	1. Ensure proper values for Tank Height and Sensor Offset 2. Check vessel for present liquid level. Trim Level can be used to ensure exact measurement 3. Reconfigure LOOP values if necessary
LEVEL reading on Display is correct but LOOP is stuck at 4 mA	HART Poll Address set a value of 1-15	Set HART Poll Address to 0
LEVEL reading on Display stuck at value related to Blocking Distance	Device believes antenna is flooded (level very near or on antenna)	Check actual level. If antenna is not flooded, power down, then power up transmitter with the level well below the antenna.

---

### 3.3.2 Error Messages

The Model R82 Radar transmitter utilizes a 3-section hierarchy for reporting diagnostic conditions: FAULTS, WARNINGS, and INFORMATION. FAULTS and WARNINGS will be shown in the Home screen when the message is active. A chronological listing of messages can be viewed in the HISTORY screen.

**FAULT:** The highest level in the hierarchy of diagnostics annunciating a defect or failure in circuitry or software that precludes reliable measurement. The current (mA) value unit defaults to 3.6, 22, or HOLD and the Home screen will freeze showing the highest priority Fault. A chronological listing of messages can be viewed in the HISTORY screen.

**WARNING (MESSAGE):** The second level in the hierarchy of Diagnostics annunciating conditions that are not fatal but may affect measurement. The highest priority Warning will be placed on the main (rotating) screen when a Warning is detected but will not affect output current. A chronological listing of messages can be viewed in the HISTORY screen.

**INFORMATION (MESSAGE):** The lowest level in the hierarchy of diagnostic conditions providing operational factors that are not critical to measurement. A chronological listing of messages can be viewed in the HISTORY screen.

**EFFECTS OF EACH DIAGNOSTIC MESSAGE**

	<b>mA Loop</b>	<b>Display Message</b>	<b>History Screen</b> ①
<b>Fault</b>	3.6/22/HOLD	Yes	Yes
<b>Warning</b>	No Effect	Yes	Yes
<b>Information</b>	No Effect	No	Yes

① Also listed in History screen are changes of "state". For example, "BC Level" which means Boundary Condition Level. This is an expression of the transmitter's internal logic.



## DIAGNOSTIC MESSAGES

	Symptom	Condition(s)	Solution(s)
Faults	DfltParmFact	Non-volatile memory corrupted	<ul style="list-style-type: none"> <li>• Modify one parameter in the section then return setting to original value (e.g., change HART POLL ADR from 0 to 1 then back to 0.</li> <li>• Consult Factory if this does not resolve the problem</li> </ul>
	DfltParm Sys		
	DfltParm Adv		
	DfltParm I/O		
	DfltParmHART		
	DfltStrapTbl		
	RFBrdFailure	Ramp interval out of tolerance	<ul style="list-style-type: none"> <li>• Check for loose connection between boards</li> <li>• Consult Factory</li> </ul>
Loop Failure	The actual current generated in the 4-20 mA loop differs significantly (> 1 mA) from the intended loop current.	Consult Factory	
SafeZoneAlrm	<p>Level has risen to within SZ Height of Blocking Distance point.</p> <p>SZ Alarm notification choices:</p> <ul style="list-style-type: none"> <li>i) 22 mA: loop driven to 22 mA while detected level remains within SZ Height of Blocking Distance point</li> <li>ii) 3.6 mA: loop driven to 3.6 mA while detected level remains within SZ Height of Deadband</li> <li>iii) Latch 22 mA: loop held at 22 mA until manually reset</li> <li>iv) Latch 3.6 mA: loop held at 3.6 mA until manually reset</li> <li>v) None: safety zone not enabled. (default Safety Zone Alarm state)</li> </ul>	<ul style="list-style-type: none"> <li>• Normal operation</li> <li>• Change parameters to modify transmitter actions</li> <li>• Keep liquid from entering this area</li> </ul>	
Echo Lost	No valid echo from the liquid surface has been received for a period exceeding the Echo Loss Delay.	<ul style="list-style-type: none"> <li>• Increase Turbulence setting</li> <li>• Decrease Dielectric setting</li> <li>• Increase Foam setting</li> <li>• Increase ROC setting</li> <li>• Increase LOE Delay</li> </ul>	
HiVolumeAlrm	The measured level exceeds the strapping table SPAN by more than 5%.	<ul style="list-style-type: none"> <li>• Increase the maximum Level/Volume capability of the table</li> <li>• Prevent liquid from reaching this level</li> </ul>	
Warnings	Initializing	Instrument is warming up	Normal operation
	LowVDC@20mA	Test_Power reading is so low that brownout may occur at high current values.	<ul style="list-style-type: none"> <li>• Reduce resistance in loop</li> <li>• Increase power supply voltage</li> </ul>
	No EchoRej	No Echo Rejection Profile has been saved	<ul style="list-style-type: none"> <li>• Run new Echo Rejection Profile</li> <li>• Turn OFF Echo Rejection warning</li> </ul>
	EchoRej Crpt	Non-volatile memory exception in Echo Rejection Profile partition	<ul style="list-style-type: none"> <li>• Re-run Echo Rejection Profile</li> <li>• Consult Factory</li> </ul>
	EchoRej Invl	A stored Echo Rejection Profile has been invalidated; typically because a key configuration parameter was changed.	Re-run Echo Rejection Profile
	EchoRej Dsbl	Echo Rejection has been disabled	<ul style="list-style-type: none"> <li>• Enable Echo Rejection</li> <li>• Turn OFF Echo Rejection warning</li> </ul>
	EchoRej Insf	Echo Rejection Curve ended within a partial Echo	Re-run Echo Rejection Profile at a higher or lower Level to avoid capturing a partial echo
	Elec Temp Hi	Electronics temperature presently above 80°C	Reduce exposure of transmitter to high temperature to avoid damage
	Elec Temp Lo	Electronics temperature presently below -40°C	Reduce exposure of transmitter to low temperature to avoid damage
	RateOfChange	Rate of level change has exceeded user setting for ROC.	Increase Rate of Change setting

**DIAGNOSTIC MESSAGES**

	<b>Symptom</b>	<b>Condition(s)</b>	<b>Solution(s)</b>
<b>Informational</b>	System Code	Unexpected but non-fatal software condition has occurred	Consult Factory
	BC Initial BC Level BC Empty BC Full BC EchoMiss BC EchoLost BC Restart	Boundary Condition State	Normal operation
	NoTargetFound	Echo processing module detected no echoes above threshold	<ul style="list-style-type: none"> <li>• Ensure proper installation</li> <li>• Ensure proper configuration-specifically Dielectric, Turbulence, Foam</li> <li>• Ensure proper application for radar</li> <li>• Consult Factory</li> </ul>
	Dist Jump	Echo processing module detected actual or impending discontinuity in distance measurement	Transmitter detecting echoes other than valid liquid level and may jump to erroneous level
	Target??	Target distance uncertain due to abnormal shape or location	Consult Factory

### 3.4 Agency Approvals

AGENCY	MODEL	PROTECTION METHOD	AREA CLASSIFICATION
<b>United States</b>  APPROVED	R82-52XA-0XX	Intrinsically Safe	Class I, Div. 1; Groups A, B, C, & D T4 @80°C; NEMA 4X, IP 66 ① Entity
	R82-51XA-0XX	Non-Incendive ②	Class I, Div. 2; Groups A, B, C, & D NEMA 4X, IP 66 ①
<b>Canada</b>  APPROVED	R82-52XA-0XX	Intrinsically Safe	Class I, Div. 1; Groups A, B, C, & D T4 @80°C; Type 4X, IP 66 ① Entity
	R82-51XA-0XX	Non-Incendive ②	Class I, Div. 2; Groups A, B, C, & D T4 @80°C; Type 4X, IP 66 ①
<b>ATEX</b> 	R82-5BXA-0XX	Intrinsically Safe ③④ EN60079-0: 2007 EN60079-11: 2007 EN60079-26: 2007 standards applied	ATEX II 1G Ex ia IIC T4 @70°C Ambient Temp: -40° to +70° C

PENDING

PENDING

NEMA rating applies to aluminum housing with Tefzel antenna only

- ② For Division 2 the measured media inside the vessel must be non-flammable only and the apparatus must be only connected to an inherently limited power source (Class 2 power supply) as defined in the NEC table 11

**Special conditions for safe use (ATEX Ex i)**

- ③ Materials marked as category 1 equipment and mounted in hazardous areas requiring this category shall be installed in such way that, even in the event of rare incidents, the aluminum enclosure cannot be an ignition source due to impact or friction.
- ④ The transmitter shall be installed so that electrostatic discharges on plastic parts are prevented.

 These units have been tested to EN61326 and are in compliance with the EMC Directive 2004/106/EC EN302 372-1 and EN301 489-1 & -3 and are in compliance with the RTTE.

**ATEX Entity Parameters**

Vi	28.4 VDC	28 VDC
Ii	94 mA	120 mA
Pi	0.67 w	0.84 w
Ci	5.5 nF	
Li	370 μH	

**SIL**

	Model R82	
SIL	1 as 1oo1	
Instrument Type	B	
SFF	89.1%	
PFDavg	3.34E-04	
	<b>FITS</b>	<b>Annual</b>
Fail Dangerous Undetected	68	5.96E-04
Fail Dangerous Detected	388	3.40E-03
Safe	169	1.48E-03

**COMMUNICATIONS APPROVALS**

Region	Agency	Frequency
US	FCC	26 GHz
Canada	IC	
Europe	RTTE	

---

### 3.4.1 Agency (FM/CSA) Drawing and Entity Parameters

---

<< drawing pending approval >>

## 3.5 Parts

### 3.5.1 Replacement Parts

Item	Description		Part Number
	Electronic Module – 26 GHz	Aluminum Housing	89-9124-001
		Lexan® Housing	89-9124-002
②	O-ring: Aluminum Housing Lexan Housing	Viton Buna N	012-2201-237 012-2616-237
	Housing Cover, Aluminum	GP/IS	036-4410-010
	Housing Cover, Lexan	GP/IS	003-1226-003

### 3.5.2 Recommended Spare Parts

Description		Part Number
Electronic Module – 26 GHz	Aluminum Housing	89-9124-001
	Lexan Housing	89-9124-002

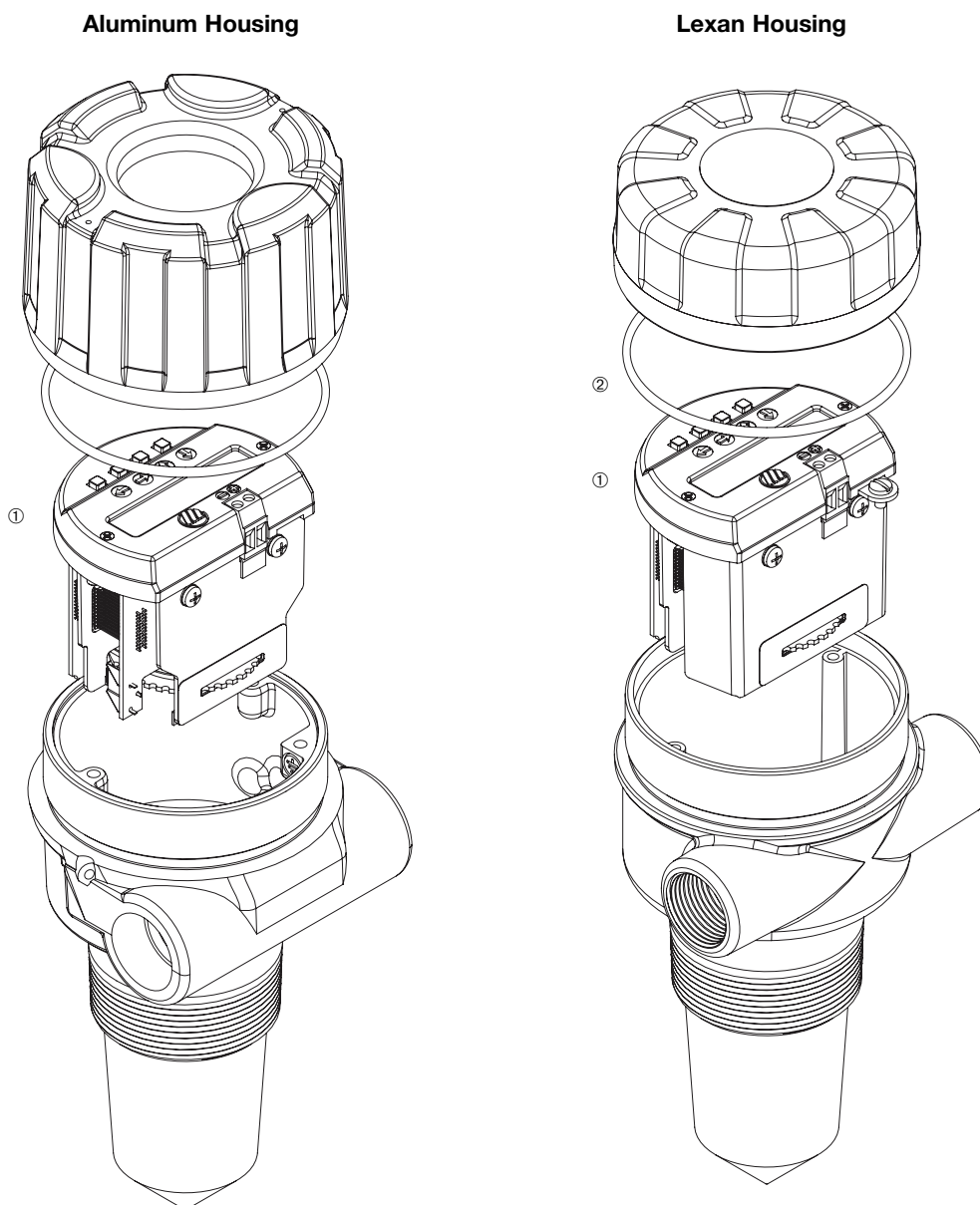

Figure 29

## 3.6 Specifications

### 3.6.1 Functional – Transmitter

#### System Design

Measurement Principle Pulse burst radar @ 26 GHz ①

#### Input

Measured Variable Level, determined by the time-of-flight of a radar pulse from transmitter to product surface and back

Span 15" to 40 feet (380 mm to 12.2 m) measured from threads

#### Output

Type Analog 4 to 20 mA with optional HART digital signal

Range Analog 3.8 to 20.5 mA useable (Namur NE43)

Digital 0 to 999" (0 to 9999 cm)

Resolution Analog 0.01 mA

Digital 0.1"

Loop Resistance GP/IS/XP - 400  $\Omega$  @ 24 VDC/20 mA, 350  $\Omega$  @ 24 VDC/22 mA

Diagnostic Alarm Adjustable 3.6 mA, 22 mA, HOLD

Damping Adjustable 0-45

Output at Antenna < .01 mW (avg), < 2 mW (max)

#### User Interface

Keypad 4-button menu-driven data entry and system security

Indication 2-line x 16-character display

Digital Communication HART Version 5 compatible

#### Power (Measured at instrument terminals)

General Purpose/Intrinsically Safe 16 to 36 VDC

RTTE: European approval, FCC & IC: North American approval

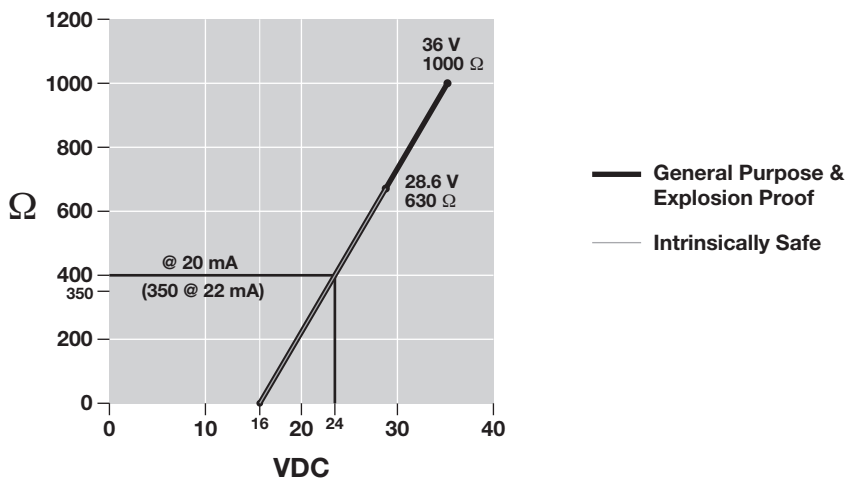

Figure 30

### 3.6.1 Functional – Transmitter (cont.)

#### Housing

Material:	Lexan® base and cover	
Cast aluminum A356T6 (<0.2% copper)		
Cable Entry:	¾" NPT, M20	
Ingress Protection:	Lexan Housing:	NEMA 6P (IP67/68) ②
	Aluminum Housing:	NEMA 4X/6P (IP67/68) ②
Net/Gross Weight:	Short Lexan	23 oz.
	Long Lexan	32 oz.
	Short Aluminum	49 oz.
	Long Aluminum	58 oz.
Overall Dimensions:	Lexan	see drawings on page 41
	Aluminum	see drawings on page 41

#### Antenna

Encapsulated Horn	Polypropylene, Tefzel® (optional)	
	-40 to +200F @atmos (-40 to 93C)	
	Vacuum to 200 psig @ 70F (-1 to 13.8 bar) Tefzel	
Wetted Surfaces	Polypropylene or Tefzel (optional)	

#### Environment

Operating Temperature	-40 to +175° F	(-40 to +80° C)
LCD	-5 to +160° F	(-20 to +70° C)
Storage Temperature	-50 to +175° F	(-46 to +80° C)
Humidity	0-99%, non-condensing	
Electromagnetic	Meets CE Requirements: EN 50081-2, EN 50082-2	
Surge Protection	Meets CE Requirements: EN 61326 (1000 volts)	
Shock Class	ANSI/ISA-S71.03 Class SA1	
Vibration Class	ANSI/ISA-S71.03 Class VC2	

② Installation for NEMA 6P/IP 68: the transmitter can be installed to allow for temporary submergence to 6.5 ft. (2 m) for 24 hours.

### 3.6.2 Performance

Reference Conditions	Reflection from ideal reflector at +70° F (+20° C)
Linearity	±0.2 inch (5 mm) or 0.05% of tank height (whichever is greater)
Measured Error	±0.2 inch (5 mm) or 0.05% of tank height (whichever is greater)
	(Performance will degrade slightly within 60" (1.5 m) of antenna)
Resolution	0.1 inch (2.5 mm)
Repeatability	< 0.1 inch (2.5 mm) or 0.025% of tank height
Response Time	< 1 second
Warm-up Time	30 seconds
Ambient Temp. Effect	0.05% per 10° C
Process Dielectric Effect	< 0.3 inch within selected range
Maximum Rate of Change	180 inches (450 cm)/minute
Minimum Dielectric:	1.7

### 3.6.3 Functional – Encapsulated Horn Antenna

Antenna	Polypropylene	Tefzel®
Process Connection	2" NPT/BSP sanitary flanges	
Maximum Process Temperature	-40° to +200° F @ atmos (-40° to +93° C @ atmos)	
Maximum Process Pressure	Vacuum to 200 psig @ +70° F (-1 to 13.8 bar @ +20° C)	
Minimum Dielectric (application dependent)	1.7	

### 3.6.4 Antenna Pressure / Temperature Ratings

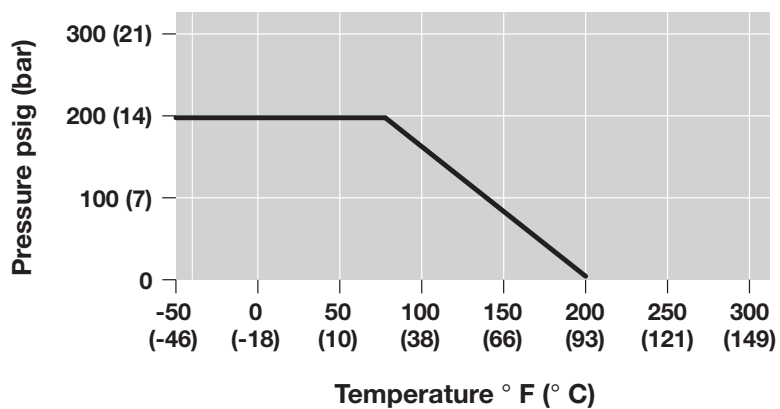

Maximum Pressure ratings for CRN are derated to 130psig (-1 to +9 bar) @70° F (20° C)

3.6.5 Physical – Inches (mm)

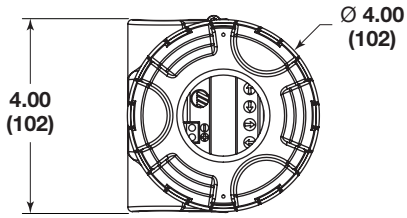

**Aluminum Housing  
Top View**

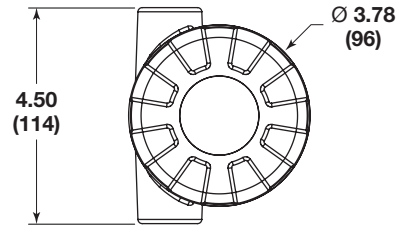

**Lexan® Housing  
Top View**

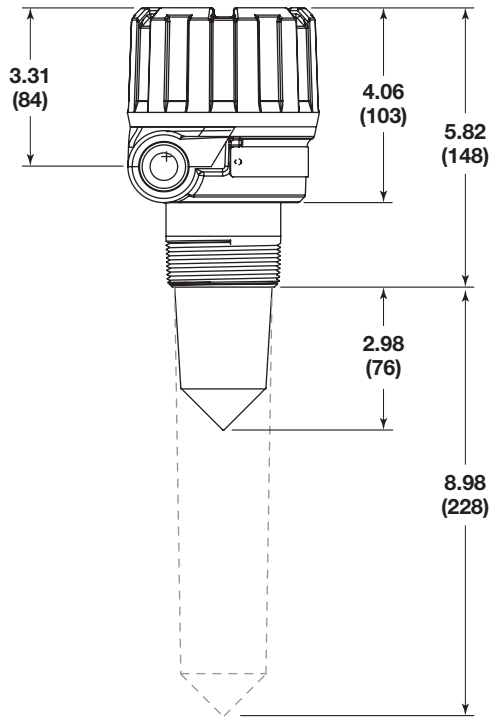

**Aluminum Housing  
Side View**

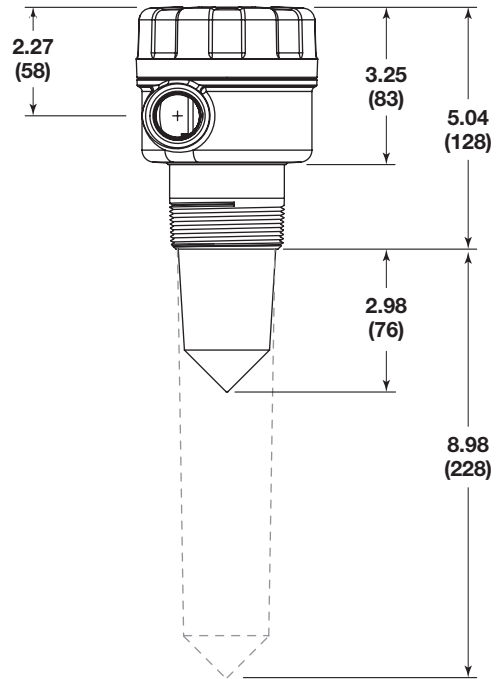

**Lexan® Housing  
Side View**

## 3.7 Model Numbers

### 3.7.1 Model R82 Radar Transmitter

#### BASIC MODEL NUMBER

R	RADAR Level Transmitter
---	-------------------------

#### OPERATING FREQUENCY

8	26 GHz
---	--------

#### TRANSMITTER MODEL

2	Economical
---	------------

#### POWER/SIGNAL

5	24 VDC, Two-wire; 4-20 mA with HART®
---	--------------------------------------

#### AGENCY CLASSIFICATION

1	Integral, General Purpose/Non-incendive (cFMus)
2	Integral, Intrinsically Safe (cFMus)
A	Integral, General Purpose
B	Integral, Intrinsically Safe (ATEX II 1G Ex ia IIC T4 @70°C)

#### HOUSING/CONDUIT CONNECTION

0	Cast Aluminum, Single Compartment; ¾" NPT
1	Cast Aluminum, Single Compartment; M20
6	Lexan® Plastic, Single Compartment, ¾" NPT
7	Lexan Plastic, Single Compartment, M20

#### ACCESSORIES

A	Digital display and keypad
---	----------------------------

#### ANTENNA TYPE

1	Polypropylene, 2" (50 mm) extension
2	Polypropylene, 8" (200 mm) extension
3	Tefzel®, 2" (50 mm) extension
4	Tefzel®, 8" (200 mm) extension

#### PROCESS CONNECTION

1	2" NPT
2	2" BSP
A	2½" Tri-Clover®
B	3" Tri-Clover
D	80 mm Tuchenhagen

Note: Options A, B and C are available with ANTENNA TYPE 3 or 4 (Tefzel) only.

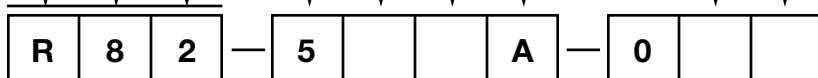

---

## Glossary

**Accuracy** The closeness of agreement between the result of measurement and the true value of the measure (inaccuracy equals the maximum positive and negative % deviation over the total span).

**ANSI** American National Standards Institute.

**Antenna** A mechanical component that serves as an impedance match between the transmission of a signal in a cable (or waveguide) and air.

**AntnaMnt** *Antenna Mount* The type of process mounting (NPT, BSP or Flange) utilized in the installation. This aids in establishing an exact Sensor Reference Point for Radar propagation and measurement.

**AntnaTyp** *Antenna Type* A particular antenna configuration or design. Each antenna design has a set of unique performance characteristics.

**ATEX** *ATmosphere EXplosive* European regulations governing the use in hazardous areas.

**BlockDist** *Blocking Distance* The area near the antenna where reflections cannot be measured effectively due to antenna ringing and noise.

**CE** *Conformité Européene* Standards and performance criteria for the new European Union.

**CENELEC** *Comité Européen de Normalisation Electrotechnique* European organization that sets standards for electrical equipment.

**CSA** *Canadian Standards Association* Canadian, third party agency that qualifies the safety of electrical equipment.

**Damping** Factor applied to smooth output variations due to turbulence.

**Default Screen** The main position of the menu structure that displays the primary measurement values of STATUS, LEVEL, ECHO STRENGTH, % OUTPUT, LOOP CURRENT, LOCAL TAG. The transmitter returns to this position after 5 minutes of inactivity (except Screens 2-6).

**Diagnostics** Three levels of error messages; Fault, Warning and Information.

**Dielectric Constant** ( $\epsilon$ ) The electrical permittivity of a material. The units are farad/meter. Typical values: Hydrocarbons 1.9–3, Glycol 32, Water-based media 80. See Technical Handbook 41-600 for complete listing.

**Dielectric Rod antenna** A non-metallic (TFE and polypropylene type) transition between the microwave waveguide and air.

**Distance** The present reading measured from the transmitter's Sensor Reference Point to the material in a vessel; compliment of Level.

**DVM/DMM** Digital Volt Meter/Digital Multimeter.

**Electromagnetic Energy** The radiation that travels through space as electric and magnetic fields varying with position and time. Examples in increasing frequency: radio waves, microwave, infrared light, visible light, ultraviolet light, x-rays, gamma waves, and cosmic waves.

**EM** See Electromagnetic Energy.

**EMI** *Electromagnetic Interference* Electrical noise caused by electromagnetic fields that may affect electrical circuits, particularly low-power electronic devices.

**EN** *European Normal* Committee guidelines in EC countries that take precedence over local, country guidelines.

**ENV** Preliminary EN guidelines, or pre-standards.

**Ergonomic** A mechanism that considers human capability in its design or function.

**ETS** *Equivalent Time Sampling* Process that captures high speed electromagnetic events in real time (nanoseconds) and reconstructs them into an equivalent time (milliseconds).

**Explosion Proof Enclosure** An enclosure designed to withstand an explosion of gas or vapor within it and prevent the explosion from spreading outside the enclosure.

**Factory Sealed** A third-party-approved Explosion Proof seal installed in the unit during manufacturing. This alleviates the end user from installing an external XP seal adjacent (within 18") to the device.

**Fault** The highest level in the hierarchy of diagnostics annunciating a defect or failure in circuitry or software that preclude reliable measurement. The current (mA) value unit defaults to 3.6, 22, or Hold and a message is displayed on the rotating screen. Further information can be obtained by viewing the Status or Diagnostic (Factory Menu) screens.

**Feedthrough** A small, connecting cavity between the main housing compartments, carrying the cable that supplies the operating energy to the measurement circuitry and returns the output value proportional to level. This cavity is potted to maintain the environmental isolation between the two compartments.

**Fiducial** A reference signal (baseline) to which all measurements are referenced.

**FM** *Factory Mutual* American, third party agency that qualifies the safety of electrical equipment.

**Foam** The entraining of air in a liquid. The effect of foam on radar measurement is based on four factors; 1.) dielectric of the liquid from which the foam has developed, 2.) density of the foam (bubble size), 3.) amount of foam above the liquid and, to a lesser extent, 4.) wall thickness of the bubbles.

---

**Four Wire** An electronic instrument design that uses one set of wires to supply power (120/240 VAC, 24 VDC) and another set to carry the process measurement signal (4–20 mA). Also called Line Powered.

**FSK** *Frequency Shift Keying* See HART.

**Gain** Amplification adjustment to attain optimum performance in various product dielectric ranges. (Factory setting).

**Ground** An electrical connection to the Earth's potential that is used as a reference for the system and electrical safety.

**Grounded** A state where no electrical potential exists between the ground (green) connection on the transmitter and the Earth or system ground.

**Guided Wave Radar** See TDR.

**HART** *Highway Addressable Remote Transducer* Protocol that uses the Bell 202 frequency shift keying (FSK) method to superimpose low level frequencies (1200/2000 Hz) on top of the standard 4–20 mA loop to provide digital communication.

**HART ID** See Poll Address.

**Hazardous Area** An area where flammable gases or vapors are or may be present in the air in quantities sufficient to produce explosive or ignitable mixtures.

**Horn Antenna** A metallic, cone transition between the microwave waveguide and air.

**IEC** *International Electrotechnical Commission* Organization that sets international standards for electrical devices.

**Increased Safety** Designs and procedures that minimize sparks, arcs, and excessive temperatures in hazardous areas. Defined by the IEC as Zone 1 environments (Ex e).

**Information (message)** The lowest level in the hierarchy of diagnostic conditions providing operational factors that are not critical to measurement. Further information can be obtained by viewing the Status or Diagnostic (Factory Menu) screens.

**Intrinsically Safe Ground** A very low resistance connecting to a ground, in accordance with the National Electrical Code (NEC, ANSI/NFPA 70 for FMRC), the Canadian Electrical Code (CEC for CSA), or the local inspector.

**Intrinsic Safety** A design or installation approach that limits the amount of energy that enters a hazardous area to eliminate the potential of creating an ignition source.

**Level** The present reading of the height of material in a vessel; compliment of Distance.

**Level Offset** *Level Offset* The distance above the tank bottom where radar level measurement is impossible due to heating coils, baffles, angled or curved tank bottoms, etc. The mA output will never read lower than the Level Offset value.

**Linearity** The worst case error calculated as a deviation from a perfect straight line drawn between two calibration points.

**Line Powered** See Four Wire.

**LOE** *Loss of Echo* Condition where a level measurement is impossible due to the absence of valid reflections from the liquid surface.

**LOE Delay** *Loss of Echo Delay* The amount of time the transmitter spends looking for a valid Level signal before going into Loss of Echo Fault. The last valid Level reading is held during this search.

**LOE Fault** *Loss of Echo Fault* The mA value to which the output is driven after the Loss of Echo Delay times out; choices are 3.6mA, 22mA and HOLD.

**Loop** The present reading of the 4–20 mA current output.

**Loop Powered** See Two Wire.

**Loop Test** *Loop Test* Built-in system capability to test/calibrate a loop (or separate loop device) by driving the transmitter output to a particular value.

**Low Voltage Directive** A European Community requirement for electrical safety and related issues of devices using 50-1000 VDC or 75–1500 VAC.

**Measured Value** The typical level measurement values used to track the level of a process: Level, % Output, and Loop.

**Media** The liquid material being measured by the level transmitter.

**Multidrop** The ability to install, wire, or communicate with multiple devices over one cable. Each device is given a unique address and ID.

**Non-hazardous Area** An area where no volatile mixtures of vapors/gas and oxygen will be found at any time. Also called General Purpose Area.

**Non-Incendive** A circuit in which any arc or thermal effect produced, under intended operating conditions of the equipment or due to opening, shorting, or grounding of field wiring, is incapable, under specific test conditions, of igniting the flammable gas, vapor, or dust-air mixture.

**Password** A numerical value between 0 and 255 that protects stored configuration data from unauthorized manipulation.

**Percent (%) Output** The present reading as a fraction of the 16 mA scale (4–20 mA).

**Poll Address (HART ID)** A number between 1 and 15 which sets an address or location of a device in a multi-drop loop. Poll address for single device configuration is 0.

**Qual** *Quality* A relative value (0–99) that shows the strength and usefulness for a given reflected signal.

**QuickStart** The essential information needed for the R82 radar transmitter and antenna to be installed, wired, and calibrated.

**Radar (Radio Detection And Ranging)** Uses EM energy and high speed timing circuits to determine distance. Original Radar devices used energy in the radio frequency range (MHz), many current devices use much higher frequencies (GHz).

---

**Range** The distance over which the transmitter scans for valid return signals.

**RateChng** *Rate of Change* The maximum velocity of vertical movement of a liquid's surface.

**Relative Dielectric** ( $\epsilon_r$ ) A unitless number that indicates the relative permittivity of a material.

**Repeatability** The maximum error between two or more output readings of the same process condition.

**RFI** *Radio Frequency Interference* Electrical noise that can have an adverse affect on electrical circuits, particularly low-power devices.

**Safety Zone** A user-defined area just below the Blocking Distance where level measurement still has a high degree of reliability. Radar can develop ambiguous readings when the level reaches the region of the antenna. An alarm can be annunciated in this area for critical applications where reliable measurement is a necessity for safety reasons.

**Safety Zone Height** The height of the region below the Blocking Distance where an alarm will be annunciated upon detection of liquid.

**Safety Zone Fault** An optional condition added, when necessary, to ensure safe, reliable high-level readings in critical applications. Choices are 3.6 mA, 22 mA, Latch 3.6 or Latch 22. If Latch 3.6 or Latch 22 are chosen, the loop current will remain in alarm until it is cleared in SZ Latch menu screen.

**Safety Zone Alarm Reset** Use screen for clearing a Latched Alarm set in **Safety Zone Fault** (above)

**SnsrOfst** *Sensor Offset* The distance (+ or -) between the customer's 100% reference point (tank top) and the Sensor reference point (bottom of NPT thread, top of BSP thread or face of flange).

**Span** The difference between the upper and lower limits of the range.

**Specific Gravity (SG)** The ratio of the density of a material to the density of water at the same conditions.

**Sensitivity** The amount of amplification applied to the Level signal; a higher value aids in measuring low dielectric media; a lower number assists in ignoring nearby objects.

**Status** The current state of the transmitter's diagnostics; screen updates every 10 seconds.

**Targets** Objects in the vessel that create reflections of the radar signal (microwave energy).

**Targ Rej** *Target Rejection* The ability to ignore reflections from objects in the vessel that are not the liquid level, i.e., false targets (e.g. pipes, ladders, baffles).

**Tank Ht** *Tank Height* The tank measurement between the 0% (tank bottom) and 100% (tank top).

**Tank Top** The 100% point in a vessel. Also considered for the type of tank top; e.g. flat, dome, etc., which affects the development of multiple echoes during high level conditions. Multiple echoes can appear as an invalid Level signal.

**TDR (Time Domain Reflectometry)** Uses a waveguide to carry EM energy to and from the surface of the media to measure distance; similar to conventional through-air Radar but much more efficient. Also called Guided Wave Radar.

**Trim 4/Trim 20** Built-in system capability to fine tune the 4 mA and 20 mA points so the transmitter output corresponds exactly to user's meter, DCS input, etc.

**Trim Lvl** *Trim Level* An offset parameter used to account for various deviations in measurement. It is an offset value that can force the transmitter to read the exact level reading.

**Turbulnc** *Turbulence* Agitation, or disturbance, of the liquid level surface; greater the agitation, greater the scattering of the radar signal (microwave energy).

**Two Wire** An electrical instrument design that uses one set of wires to provide both the supply power and process measurement signal. The process measurement is achieved by varying the current of the loop. Also called Loop Powered.

**Units** The engineering units used to measure level in the system. The choices are in (inches) and cm (centimeters).

**Warning (message)** The second level in the hierarchy of Diagnostics annunciating conditions that are not fatal but may affect measurement. A message will occur on the main (rotating) screen when a Warning is detected but will not affect output current. Further information can be obtained by viewing the Status or Diagnostic screens.



# R82 Radar Transmitter

## Configuration Data Sheet

Company \_\_\_\_\_

Date \_\_\_\_\_

Copy blank page and store calibration data for future reference and troubleshooting.

Item	Value	Value	History	Device Status	Run Time	
				Occurred	Duration	
Vessel Name			Event 19			
Vessel #				18		
Media				17		
Media Dielectric				16		
Tag #				15		
Level				14		
Measurement Type				13		
Units				12		
Sensor Offset				11		
Tank Top				10		
Tank Height				9		
Blocking Distance				8		
Level Offset				7		
Dielectric				6		
Turbulence				5		
Foam				4		
Rate of Change				3		
Echo List Mode				2		
Echoes #1				1		
#2						
#3						
#4						
#5						
			<b>Item (factory defaults)</b>	<b>Value</b>	<b>Value</b>	
Echo Rejection			Run Time			
Loop Control			System Code			
4 mA point			Electronics Temp			
20 mA point			Max. Temperature			
Damping			Min. Temperature			
System Fault			VDC Check Midpoint			
LOE Fault			Antenna Mount			
LOE Delay			Target Algorithm			
SZ Fault			TVG Minimum			
SZ Height			TVG Maximum			
SZ Alarm Reset			Peak Detect Reference			
Trim Level			Peak Detect Threshold			
Pipe I.D.			Min Thresold			
Trim 4 mA			# Run Average			
Trim 20 mA			# Adapt Average			
Test 4-20 Loop			Scatter High Limit			
HART Poll Address			Rate High Limit			
New Password			Scatter Rate			
Language			Lvl ROC per Min			
Serial Number			Max ROC per Min			
Model R82 VerX.XXX			Max Distance Jump			
			Boundary State			
			Empty State Delay			
			NSP Value			
			HART Device ID			

---

## Notes

# IMPORTANT

## SERVICE POLICY

Owners of Magnetrol products may request the return of a control; or, any part of a control for complete rebuilding or replacement. They will be rebuilt or replaced promptly. Magnetrol International will repair or replace the control, at no cost to the purchaser, (or owner) **other than transportation cost** if:

- a. Returned within the warranty period; and,
- b. The factory inspection finds the cause of the malfunction to be defective material or workmanship.

If the trouble is the result of conditions beyond our control; or, is **NOT** covered by the warranty, there will be charges for labour and the parts required to rebuild or replace the equipment.

In some cases, it may be expedient to ship replacement parts; or, in extreme cases a complete new control, to replace the original equipment before it is returned. If this is desired, notify the factory of both the model and serial numbers of the control to be replaced. In such cases, credit for the materials returned, will be determined on the basis of the applicability of our warranty.

No claims for misapplication, labour, direct or consequential damage will be allowed.

## RETURNED MATERIAL PROCEDURE

So that we may efficiently process any materials that are returned, it is essential that a "Return Material Authorisation" (RMA) form will be obtained from the factory. It is mandatory that this form will be attached to each material returned. This form is available through Magnetrol's local representative or by contacting the factory. Please supply the following information:

1. Purchaser Name
2. Description of Material
3. Serial Number and Ref Number
4. Desired Action
5. Reason for Return
6. Process details

All shipments returned to the factory must be by prepaid transportation. Magnetrol **will not accept** collect shipments.

All replacements will be shipped FOB factory.

BULLETIN N°: BE 58-610.0  
EFFECTIVE: SEPTEMBER 2009  
SUPERSEDES: New

UNDER RESERVE OF MODIFICATIONS



www.magnetrol.com

BENELUX FRANCE	Heikensstraat 6, 9240 Zele, België - Belgique Tél. +32 (0)52.45.11.11 • Fax. +32 (0)52.45.09.93 • E-Mail: info@magnetrol.be
DEUTSCHLAND	Alte Ziegelei 2-4, D-51491 Overath Tel. +49 (0)2204 / 9536-0 • Fax. +49 (0)2204 / 9536-53 • E-Mail: vertrieb@magnetrol.de
INDIA	C-20 Community Centre, Janakpuri, New Delhi - 110 0058 Tel. +91 (11) 41661840 • Fax +91 (11) 41661843 • E-Mail: info@magnetrolindia.com
ITALIA	Via Arese 12, I-20159 Milano Tel. +39 02 607.22.98 (R.A.) • Fax. +39 02 668.66.52 • E-Mail: mit.gen@magnetrol.it
U.A.E.	DAFZA Office 5EA 722 • PO Box 293671 • Dubai Tel. +971-4-6091735 • Fax +971-4-6091736 • E-Mail: info@magnetrol.ae
UNITED KINGDOM	Unit 1 Regent Business Centre, Jubilee Road Burgess Hill West Sussex RH 15 9TL Tel. +44 (0)1444 871313 • Fax +44 (0)1444 871317 • E-Mail: sales@magnetrol.co.uk