

**PROBE INSTALLATION**

The insertion probe used with Magnetrol’s TA1 or TA2 measures the mass flow at the point the sensor is located. Therefore, the measured flow is affected by the flow profile in the pipe or duct.

The recommended location of the probe is at the center line of the pipe. With a fully developed turbulent flow profile, the velocity profile at this point is relatively flat as shown in Figure 1. For all practical purposes in gas flow applications using the TA1 or the TA2, a turbulent flow profile condition will exist.

Theoretically, the velocity at the wall of the pipe is zero and the velocity at the center line is 20 % higher than the average velocity. However this flow profile will change slightly with changes in flow rate and pipe roughness (Figure 1). Our recommendations for placing the sensor at the center line is because the flow profile at this location is relatively flat and is less effected by changes in flow profile. This location is also used as it establishes a reference for calculation of the probe blockage factor.

A fully developed turbulent flow profile is obtained with sufficient length of straight run. The amount of straight run is dependent upon the upstream conditions. As the gas flows around an elbow, the momentum causes the gas velocity on the outside of the elbow to increase and the velocity on the inside to decrease (Figure 2). A double elbow further complicates the flow profile.

In addition to changing the flow profile, as the gas flows around an elbow, a rotational component or swirl is introduced into the flow (Figure 3). Given sufficient length, the swirl pattern will dissipate and the flow profile will redevelop.

Historically it has been considered that the flow meter should be located 10 diameters downstream and 5 diameters upstream from an elbow to obtain a developed flow profile. Recent investigations by NIST (National Institute for Standards and Technology) have shown that these dimensions are not adequate, especially in cases where there is a double out of plane elbow (Figure 4).

Based upon this and other data, Magnetrol has developed the following recommendations for the optimum location of the probe for several common installation configurations. These are shown in Figure 4.

From a practical side, most process flow measurement requires repeatability in flow measurement. Despite the fact that today’s process plants often do not provide sufficient straight run to obtain optimum flow profile, an insertion probe with less straight run than indicated can still provide desirable, repeatable flow measurement.

Both the TA1 and TA2 Mass Flow Transmitters permit the user to enter correction factors via the software which will adjust the measured flow for the flow profile. This can easily be done and the procedure is included in the instruction manual. We have seen applications where users have inserted the probe directly in a large air duct for combustion

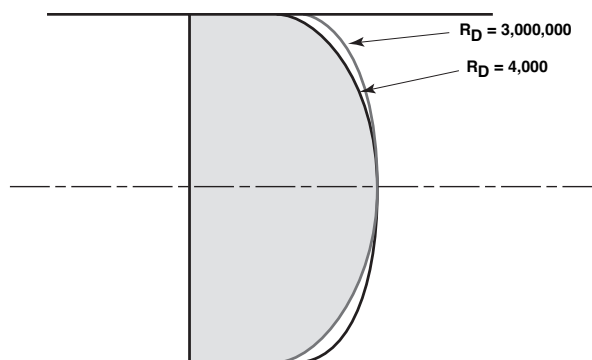

**Figure 1**  
**Turbulent Flow Profile**

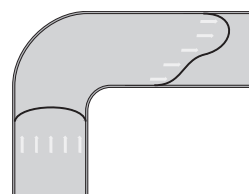

**Figure 2**  
**Flow Profile Following Single Elbow**

air control. The probe is located a short distance from a 90 ° bend. A repeatable flow measurement is obtained to permit the user to optimize the operation of the boiler (Figure 5).

In other cases where the probe is installed in a non ideal location, users have used the probe supplied with the instrument to determine the flow profile and establish the relationship between the average flow and the measured flow at the point the probe is inserted. A correction factor is determined and entered into the software. Often the factor is approximately 0.8 which reflects the fact that the centerline velocity is 20 % higher than the average velocity.

The TA1 and TA2 with insertion probe will provide excellent repeatable flow measurement based upon the flow profile in the pipe. The user has the ability to adjust the flow measurements. The above suggestions serve as a guide for optimum conditions, however, it must be recognized that optimum conditions rarely exist and repeatability in flow measurements is generally accepted.

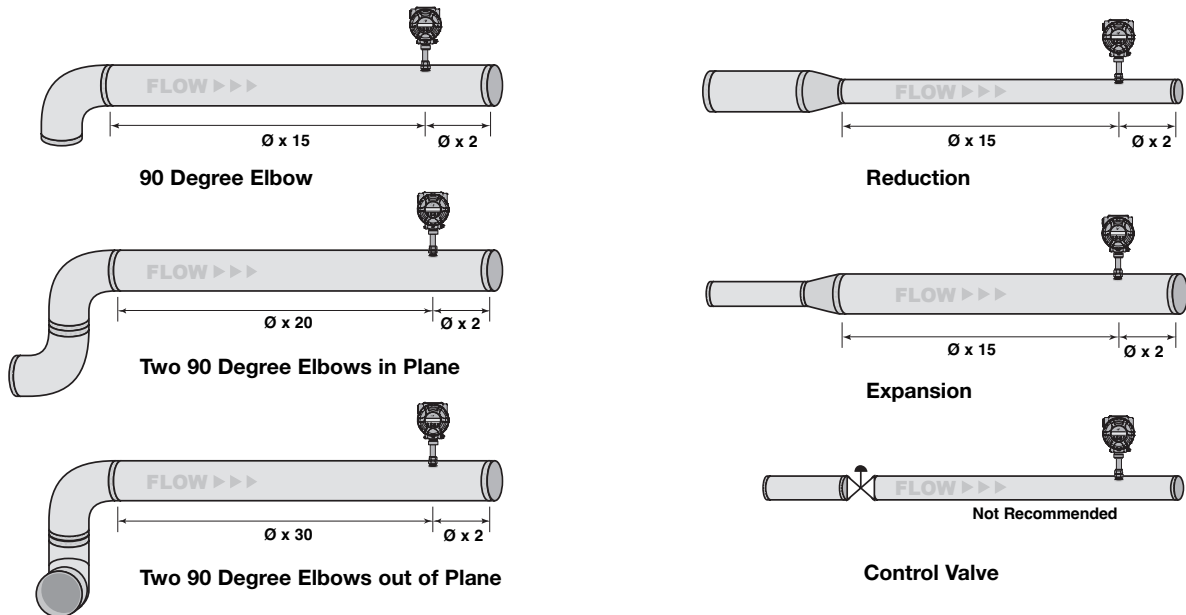

Figure 4 – Probe Installations

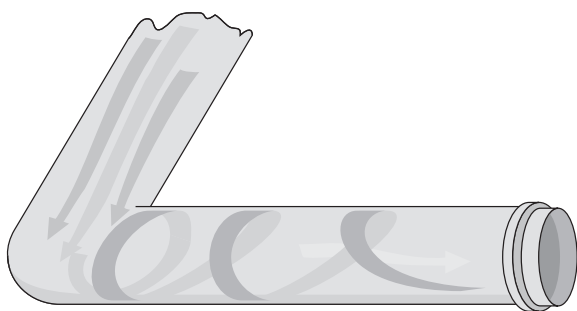

Figure 3  
Swirl Patterns in a Pipe

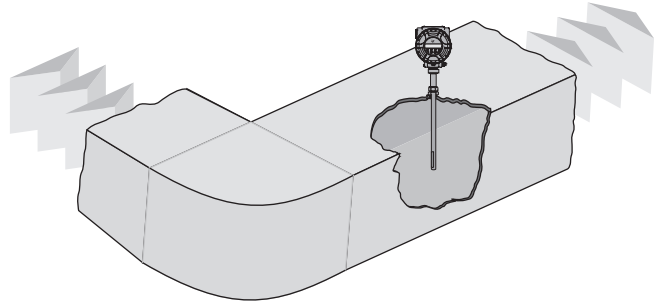

Figure 5  
Probe in a Duct  
Downstream of Elbow

**References:**

Richard W. Miller, Flow Measurement Engineering Handbook, Second Edition, 1989, McGraw-Hill Book Company

"Flowmeter Installation Effects Due to Several Elbow Configurations", G. E. Mattingly and T. T. Yeh, National Institute of Standards and Technology, 1992



**QUALITY ASSURANCE - ISO 9001**

THE QUALITY ASSURANCE SYSTEM IN PLACE AT MAGNETROL GUARANTEES THE HIGHEST LEVEL OF QUALITY DURING THE DESIGN, THE CONSTRUCTION AND THE SERVICE OF CONTROLS. OUR QUALITY ASSURANCE SYSTEM IS APPROVED AND CERTIFIED TO ISO 9001 AND OUR TOTAL COMPANY IS COMMITTED TO PROVIDING FULL CUSTOMER SATISFACTION BOTH IN QUALITY PRODUCTS AND QUALITY SERVICE.

**PRODUCT WARRANTY**

ALL MAGNETROL ELECTRONIC AND ULTRASONIC LEVEL CONTROLS ARE WARRANTED FREE OF DEFECTS IN MATERIALS AND WORKMANSHIP FOR ONE FULL YEAR FROM THE DATE OF ORIGINAL FACTORY SHIPMENT. IF RETURNED WITHIN THE WARRANTY PERIOD; AND, UPON FACTORY INSPECTION OF THE CONTROL, THE CAUSE OF THE CLAIM IS DETERMINED TO BE COVERED UNDER THE WARRANTY; THEN, MAGNETROL INTERNATIONAL WILL REPAIR OR REPLACE THE CONTROL AT NO COST TO THE PURCHASER (OR OWNER) OTHER THAN TRANSPORTATION. MAGNETROL SHALL NOT BE LIABLE FOR MISAPPLICATION, LABOR CLAIMS, DIRECT OR CONSEQUENTIAL DAMAGE OR EXPENSE ARISING FROM THE INSTALLATION OR USE OF THE EQUIPMENT. THERE ARE NO OTHER WARRANTIES EXPRESSED OR IMPLIED, EXCEPT, SPECIAL WRITTEN WARRANTIES COVERING SOME MAGNETROL PRODUCTS.



BULLETIN N°:  
EFFECTIVE:  
SUPERSEDES:

BE 54-131.0  
FEBRUARY 2003  
New

UNDER RESERVE OF MODIFICATIONS

BENELUX	Heikensstraat 6, 9240 Zele, België Tel. +32 (0)52.45.11.11 • Fax. +32 (0)52.45.09.93 • E-Mail: info@magnetrol.be
DEUTSCHLAND	Schloßstraße 76, D-51429 Bergisch Gladbach-Bensberg Tel. 02204 / 9536-0 • Fax. 02204 / 9536-53 • E-Mail: vertrieb@magnetrol.de
FRANCE	Le Vinci 6 - Parc d'activités de Mitry Compans, 1, rue Becquerel, 77290 Mitry Mory Tel. 01.60.93.99.50 • Fax. 01.60.93.99.51 • E-Mail: magnetrolfrance@wanadoo.fr
ITALIA	Via Aresè 12, I-20159 Milano Tel. (02) 607.22.98 (R.A.) • Fax. (02) 668.66.52 • E-Mail: mit.gen@magnetrol.it
UNITED KINGDOM	Unit 1 Regent Business Centre, Jubilee Road Burgess Hill West Sussex RH 15 9TL Tel. (01444) 871313 • Fax (01444) 871317 • E-Mail: sales@magnetrol.co.uk
INDIA	B4/115 Safdurjung Enclave, New Delhi 110 029 Tel. 91 (11) 6186211 • Fax 91 (11) 6186418 • E-Mail: magnetri@del2.vsnl.net.in

www.magnetrol.com

**OUR NEAREST REPRESENTATIVE**