

THERMATEL® MODEL TD1/TD2

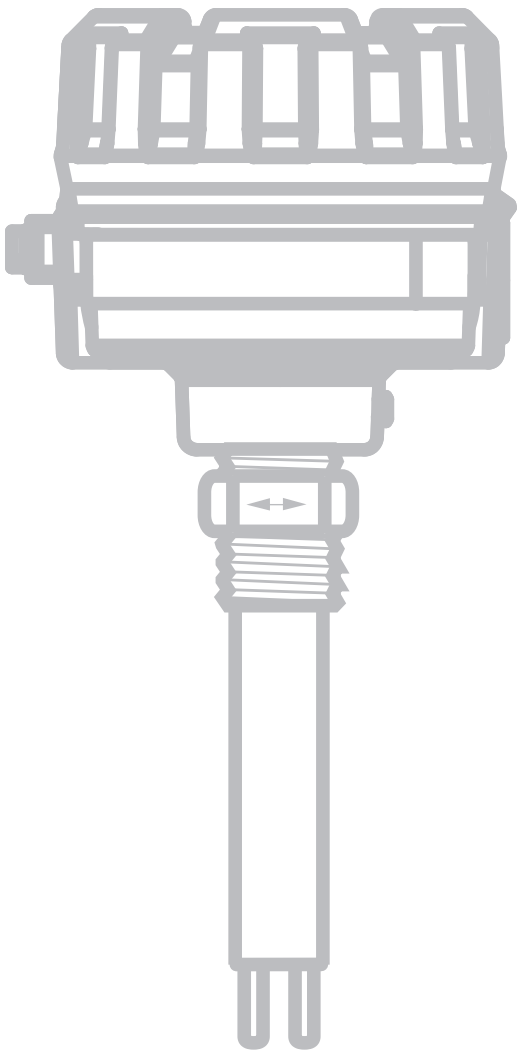

Installation and Operating Manual



Thermal

Dispersion

Level/Flow/Interface

Switch

7xxx

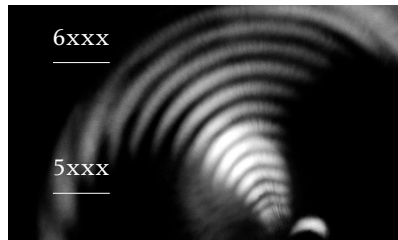

6xxx

5xxx

4xxx

3xxx

2xxx

1xxx

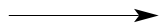

Magnetrol®

UNPACKING

Unpack the instrument carefully. Make sure all components have been removed from the foam protection. Inspect all components for damage. Report any concealed damage to the carrier within 24 hours. Check the contents of the carton/crates against the packing slip and report any discrepancies to Magnetrol. Check the nameplate model number (Model number/approvals as per inserted separate sheet) to be sure it agrees with the packing slip and purchase order. Check and record the serial number for future reference when ordering parts.

Nameplate:
 - partnumber amplifier - sensor
 - serial n°
 - tag n°



Set up Sticker

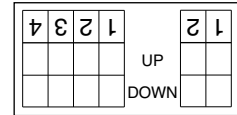

These units are in compliance with:

1. The EMC directive 2004/108/EC. The units have been tested to EN 61326: 1997 + A1 + A2
2. Directive 94/9/EC (ATEX 95A) for equipment or protective system intended for use in potentially explosive atmospheres. EC-type examination certificate number ISSeP00ATEX006 (DIN Rail housing) and ISSeP00ATEX007X (sensor and sensor enclosure).
3. The PED directive 97/23/EC (pressure equipment directive). Safety accessories per category IV module H1.

MOUNTING

FLOW

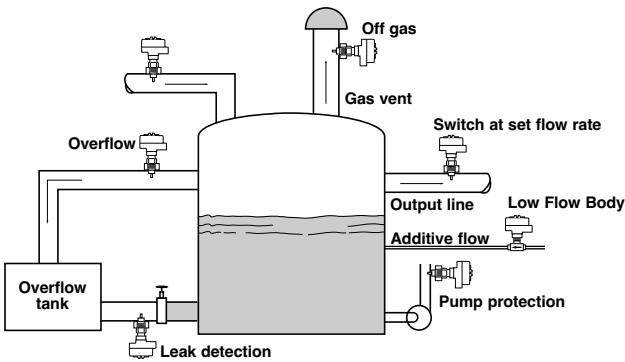

- Liquid or Gas flow detection
- Maintain a minimum flow rate
 - Pump protection
 - Cooling air/water
- Detect presence of flow
 - Relief valves / Flare lines

LEVEL

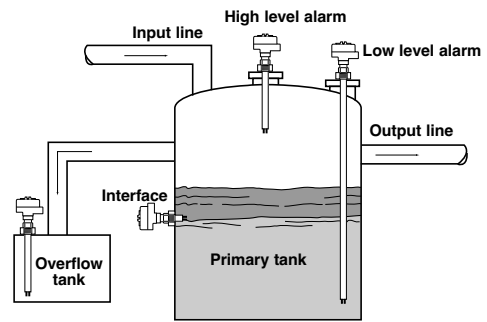

- High level or Low level
- Interface between different medias
 - Oil/water
 - Liquid/solids
- Suitable for any liquid level detection including:
 - High viscosity, High solids content
 - Aeration, Foam

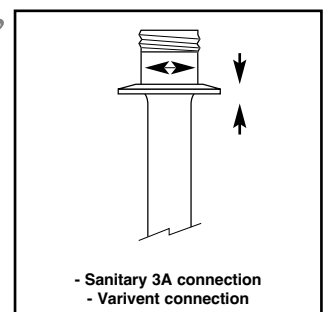
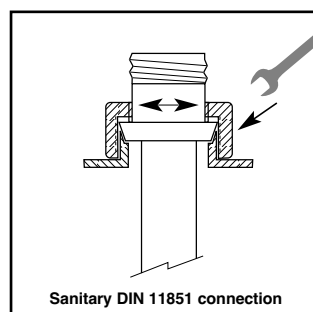
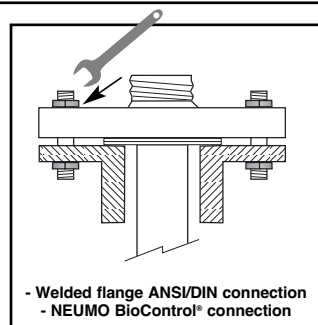
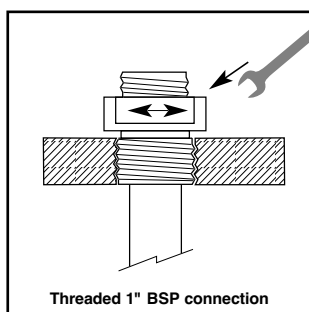
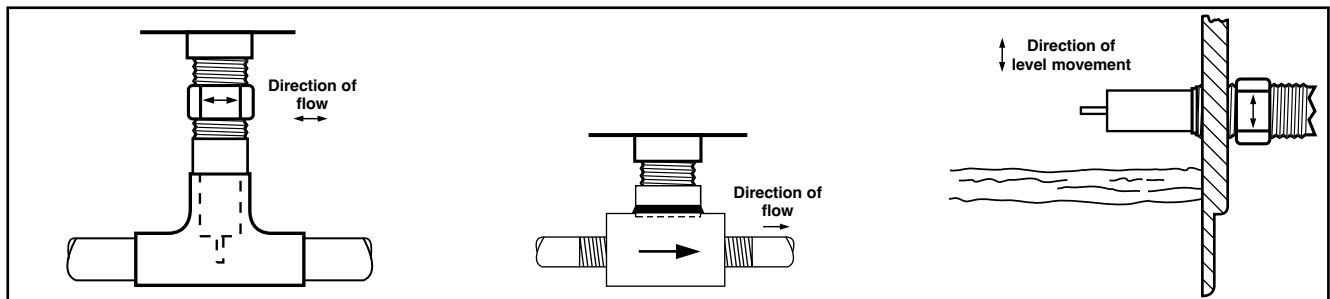

WIRING

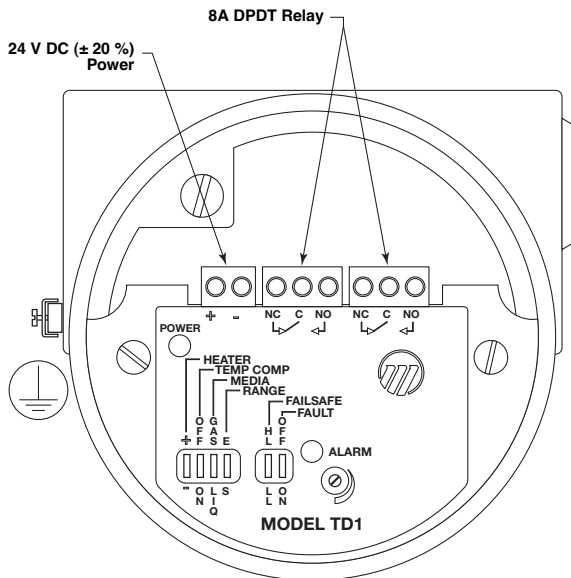

TD1 Wiring

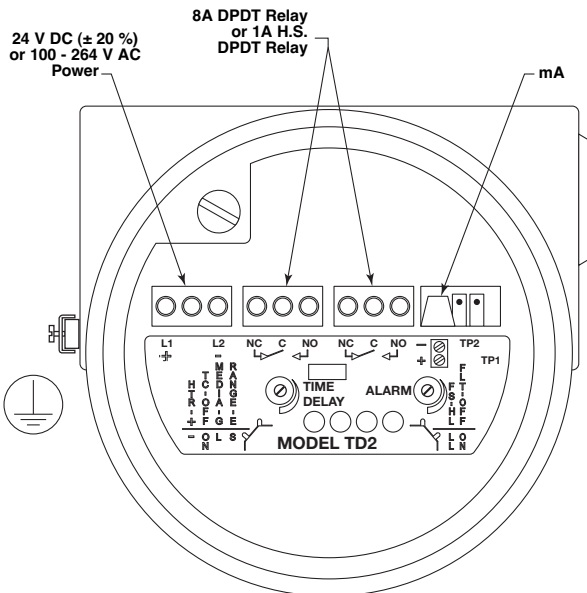

Integral TD2 Wiring

Note: For ATEX II 1G / zone 0: mA signal can only be connected when a Thermatel sensor of 1 mm wall thickness is used.

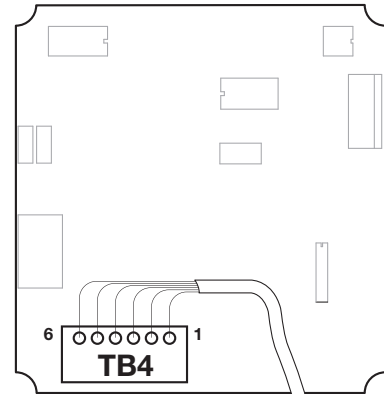

1 - white
2 - black
3 - red
4 - green
5 - orange
6 - blue

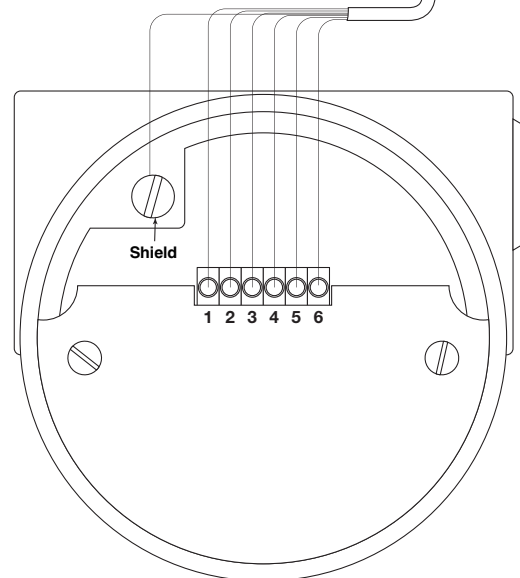

Remote TD2 Wiring

RELAY CONNECTIONS

Power	Level	Fail-safe position	Relay coil	Relay terminals	
				NC to C	NO to C
On	High	HLFS	De-energized	Closed	Open
		LLFS	Energized	Open	Closed
	Low	HLFS	Energized	Open	Closed
		LLFS	De-energized	Closed	Open
Fail	High	HLFS	De-energized	Closed	Open
		LLFS	De-energized	Closed	Open
	Low	HLFS	De-energized	Closed	Open
		LLFS	De-energized	Closed	Open

CHART NOTES AND DEFINITIONS:

- Equipment controlled by Thermatel® relays is assumed to be powered from one source, while the Thermatel® unit itself is assumed to be powered from a different source.
- “Fail” means a loss of power to the Thermatel® unit.
- HLFS (High Level Fail-safe) means a flow rate or level which is equal to or above the set point.
- LLFS (Low Level Fail-safe) means a flow rate or level which is equal to or below the set point.
- When the relay coil is de-energized, a connection is made between the terminals COM (common) and NC (normally closed), and there is no connection between COM and NO (normally open).
- When the relay coil is energized, a connection is made between the terminals COM and NO, and there is no connection between COM and NC.

SETUP AND FUNCTIONS

Indication and functions

MODEL TD1

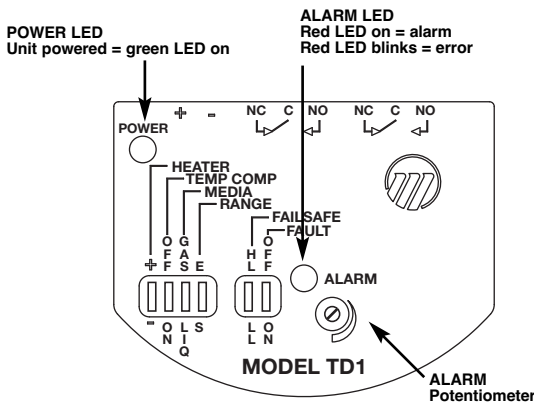

Note: during initial power-on, red LED will blink slowly.

MODEL TD2

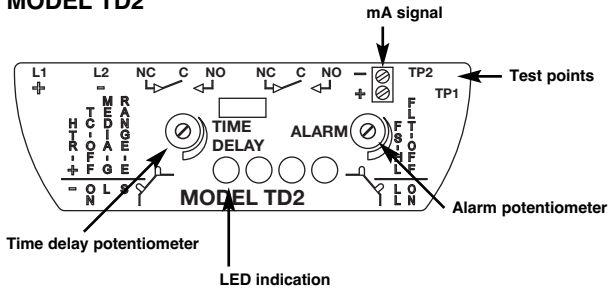

Note: during initial power-on, all LED's will turn on and individually OFF = unit ready.

ALARM (TD1/TD2)



FAIL-SAFE (TD1/TD2):

HLFS (High Level Fail-safe):
Relay is energized when flow < setpoint or sensor dry (or in the low conductive liquid).

Relay is de-energized when flow ≥ setpoint or sensor is immersed (or in the higher conductive liquid).

LLFS (Low Level Fail-safe):

Relay is energized when flow > setpoint or sensor is immersed (or in the higher thermal conductive liquid).

Relay is de-energized when flow ≤ setpoint or sensor dry (or in the lower thermal conductive liquid).

mA SIGNAL (TD2):

The mA is a non linear signal of the actual process conditions;

- for flow: mA output increases as the flow rate increases

- for level: mA output increases when in a wet condition.

The mA value depends upon sensor and application.

Error reporting is determined by setting of the Fail Safe mode;

- failsafe low ≤ 3,6 mA

- failsafe high ≥ 22 mA

TESTPOINTS (TD2):

Measure and record the voltage between TP1 and TP2.

This voltage will change as the set point potentiometer is adjusted.

Voltage readings will be between 0 and 5 VDC. This value may be used for future reference or adjustment of set point. This value can be recorded and checked in the future to ensure that the set point has not changed since last calibration.

TIME DELAY POTENTIOMETER (TD2):

Before calibration, turn fully counterclockwise until click (max. 30 turns) = 0 s.

LED INDICATION (TD1/TD2):

(in accordance with fail-safe mode)

green LED ON = safe (one or more of the 2 green LED's) (TD2)

yellow LED ON = reaching switch point (TD2)

Red LED ON = alarm (TD1/TD2)

LED BLINKS = error (TD1/TD2).

Switch setup

The TD1/TD2 switch settings are pre-set from factory. The factory default settings are marked on the sticker on the electronics. These positions may need to be changed, depending upon the application – consult the following table.

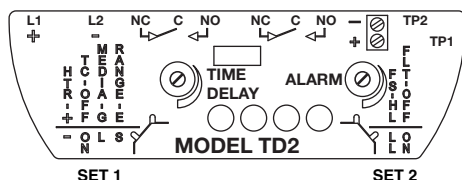
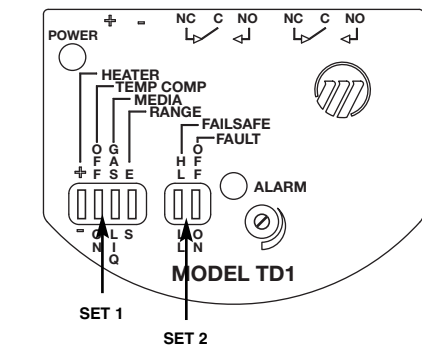
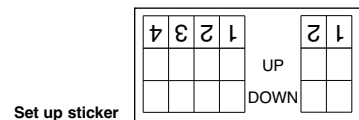

SET 1

TD1/TD2	Purpose	Settings
HEATER / HTR (4)	Control heat to sensor	+ for flow applications - for level applications
TEMP COMP / TC (3)	De-activate temperature compensation	OFF: use only in case recommended by factory ON: default setting
MEDIA (2)	Gas or Liquid	G: Gases L: Liquids, default setting for TMH/TML sensors
RANGE (1)	Increase sensitivity	E: for water flow applications S: default setting

SET 2

TD1/TD2	Purpose	Settings
FAILSAFE / FS (2)	Failsafe setting	HL: High Level Fail-safe LL: Low Level Fail-safe
FAULT / FLT (1)	De-activate fault indication	OFF: use only in case recommended by factory ON: default setting

CALIBRATION

NOTE: Ensure that settings on page 3 have been verified before calibrating this unit. Adjust level, interface or flow to the desired alarm condition of the actual liquid or gas. Units are preferably field calibrated under operating conditions or bench calibrated if the real conditions can be simulated. Consult factory when this cannot be established.

High flow / High level - Interface

High Level Adjustment (High Level Fail-safe)

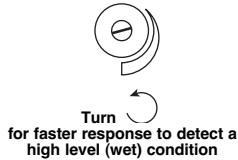

High Flow Adjustment (High Level Fail-safe)

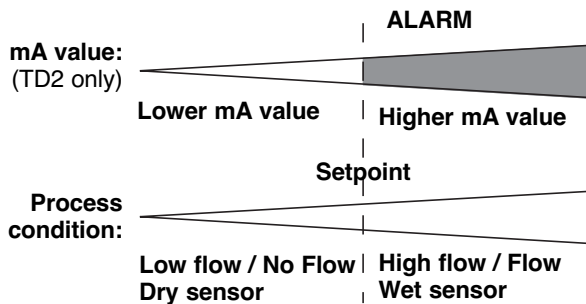
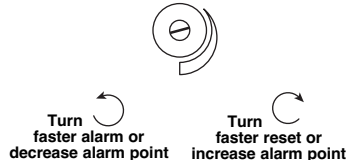

LED indication: ○ ○ ● ●
G G Y R

1. Set Time delay to minimum (turn max 30 turns counter-clockwise or until a clicking sound is heard) - only TD2.
2. Set Failsafe switch in "High" mode.
3. Set Alarm potentiometer until red LED is ON. Allow some time for the switch to stabilize (check mA output - only TD2).

Relay will be de-energized, if flow or level is higher than the actual set point or the unit sees the most thermal conductive media.

4. Reset Alarm potentiometer until Red LED is OFF and both green LED's (only TD2) light UP (turn clockwise) – tweak the potentiometer slowly back and forth until the desired set point is reached = Red LED ON.

Typical response time for level is within 3 - 5 s.

Typical response time for flow is within 2 - 15 s, depending on the application.

Low flow / No flow / Low level - Interface

Low Level Adjustment (Low Level Fail-safe)

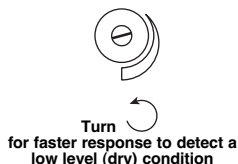

Low Flow Adjustment (Low Level Fail-safe)

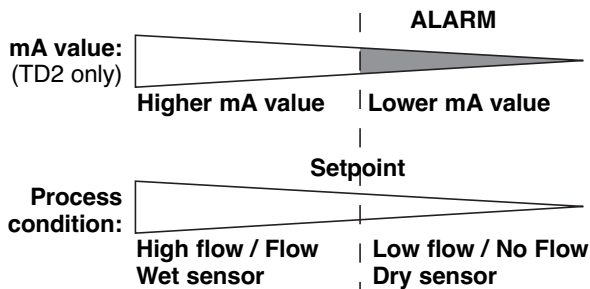
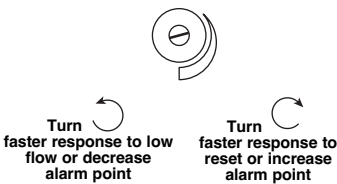

LED indication: ○ ○ ● ●
G G Y R

1. Set Time delay to minimum (turn max 30 turns counter-clockwise or until a clicking sound is heard) - only TD2.
2. Set Failsafe switch in "Low" mode
3. Set Alarm potentiometer until: (turn counterclockwise) red LED is ON. Allow some time for the switch to stabilize (check mA output - only TD2).

Relay will be de-energized, if flow or level is lower than the actual set point or the unit sees the least thermal conductive media.

4. Reset Alarm potentiometer until Red LED is OFF and both green LED's (only TD2) light UP (turn clockwise) – tweak the potentiometer slowly back and forth until the desired set point is reached = Red LED ON.

Typical response time for level is within 5 - 10 s.

Typical response time for flow is within 2 - 15 s, depending on the application.

MAINTENANCE

Troubleshooting

TD1/TD2 have continuous diagnostics to ensure that the signal from the sensor is within a select range. If the electronics detect an “out of range” signal, the switch has registered an instrument error.

TD1: Alarm LED blinks and the relay de-energizes

TD2: 3,6 mA signal when unit is set for low level fail-safe
22 mA signal when unit is set for high level fail-safe.
Alarm LED blinks and the relay de-energizes

Symptom	Problem	Solution / Action
Red LED does not go ON	Switch point cannot be established for air flow detection	Check whether probe is extended into the flow. Change Heater to “-” ①
Green LED OFF (TD1) All LED's OFF (TD2)	No power	1. Check power supply 2. Check wiring at wiring terminals
Red LED blinks and $\leq 3,6$ mA or ≥ 22 mA (TD2)	An instrument error has been registered	By changing the switch settings, the unit may return to normal operation mode. If not, consult factory.

Fault indication

TD1/TD2 have continuous diagnostics to ensure that the signal from the sensor is within a select range. If the electronics detect an “out of range” signal, the switch has registered an instrument error.

TD1: Alarm LED blinks and the relay de-energizes

TD2: 3,6 mA signal when unit is set for low level fail-safe
22 mA signal when unit is set for high level fail-safe.
Alarm LED blinks and the relay de-energizes

Sensor condition	Switch ①	Indication	Solution
Level application – Verify whether Heater is at “-”			
Sensor is wet	Heater to “-”	LED stops BLINKING	Contact factory to discuss application
Sensor is dry	Fault “OFF”	LED stops BLINKING	Operate in Fault “OFF” and Heater “-”
Flow application – Verify whether Heater is at “+”			
No flow – dry sensor	Fault “OFF”	LED stops BLINKING	Operate in: Fault “OFF” and Heater “+” or Fault “ON” and Heater “-”
No flow – wet sensor	Heater to “-”	LED stops BLINKING	Operate in: Fault “OFF” and Heater “+” or Fault “ON” and Heater “-”
Flow – liquids	Temperature compensation “OFF”	LED stops BLINKING	Operate in: Temperature compensation “OFF”
Flow – air/gases	Heater to “-”	LED stops BLINKING	Tweek calibration potentiometer clockwise (less sensitive). If problem persists, operate in: Temperature compensation “OFF” (requires re-calibration) or Fault “OFF” and Heater “+”
For all above conditions and settings		LED stays BLINKING	Probe and/or electronics may need to be replaced. Check resistance values as per below table. Consult factory if these are out of range.

① See switch settings at page 4

Resistance values

Apply a voltage meter to check the resistance values.

Connect pins TD1	Expected resistance	Connect pins TD2	
		Integral	Remote
1 to 3	90 to 180 Ω (275 Ω for TMH sensor)	1 to 4	1 to 3
2 to 4	90 to 180 Ω (275 Ω for TMH sensor)	2 to 5	2 to 4
	0 to 12 Ω (integral TD2) Open (remote TD2)	1 to 2 3 to 4 5 to 6	1 to 4 2 to 3

SPECIFICATIONS

Electronic specifications

Description		TD1	TD2
Power at terminals		19.2 to 28.8 V DC	19.2 to 28.8 V DC 100 to 264 V AC, 50-60 Hz
Power consumption		3,5 W @ 24 V DC	4 W @ 24 V DC or 5 W @ 264 V DC
Flow range		Standard sensors: 0,003 to 1,5 m/s (0.01 to 5.0 FPS) – water 0,03 to 150 m/s (0.1 to 500 FPS) – air HTHP, Hastelloy C / Monel: (1 mm wall sensors) 0,003 to 0,3 m/s (0.01 to 1.0 FPS) – water 0,03 to 150 m/s (0.1 to 500 FPS) – air 1/4" Low flow body: 0,02 to 5,7 l/h – water and min 0,006 Nm ³ /h – air/gases 1/2" Low flow body: 0,04 to 11,5 l/h – water and min 0,015 Nm ³ /h – air/gases	
Signal output	Alarm	8 A DPDT relay @ 30 V DC	8 A DPDT relay @ 30 V DC / 250 V AC 1 A HS DPDT relay @ 28 V DC
	Continuous	Not applicable	non linear mA for trending
	Error	Via alarm relay	3.6 mA (Low FS) – 22 mA (High FS) and alarm relay
Damping		Not available	0 to 100 s (in addition to sensor response)
User interface		Local switches for gain setting, function setting and Hi/Lo failsafe Calibration and damping via potentiometer	
Display		LED's for Power/Alarm status	2 green LED's (safe condition), 1 yellow LED (alarm setpoint being approached) 1 red LED (alarm condition)
Approvals		II 2 G EEx d IIC T5, explosion proof - TD2 for zone 1 II 1/2 G EEx d{ib} IIC T5, explosion proof - TD1 & TD2 - TD1 for all sensors and outputs for zone 1 & 0 - TD2 with 1mm wall thickness sensor/ 8A DPDT relay for zone 0 II 1/2 G EEx d IIC T5, explosion proof - TD2 with 1mm wall thickness sensor/ Hermetically sealed relay for zone 0	
SIL (Safety Integrity Level)		Functional safety to SIL1/SIL2 in accordance to IEC 61508 – SFF of 69,3 % (TD1) and 73 % (TD2) – full FMEDA reports and declaration sheets available	
Housing materials		IP66, Cast aluminium epoxy coated or cast stainless steel	
Net and gross weight		2 kg (4.6 lbs) with 50 mm (2") sensor	

Performance

Description	Specification
Response time	1-10 s typical (dependant on sensor type, application and set point)
Repeatability	< 1 % @ constant °C
Ambient temperature	-40 to +70 °C (-40 to +158 °F) – operational -50 to +76 °C (-58 to +170 °F) – storage
Humidity	0-99 % non condensing
Electromagnetic compatibility	Meets CE requirements (EN 61326: A1 + A2) and Namur NE 21

Sensor specifications

Description	Twin tip - spherical sensors TMM - TMA/TMB - TMC/TMD	HTHP sensor TMH	Low flow body TML
Materials	316/316L (1.4401/1.4404) Hastelloy C (2.4819) - TMC/TMD Monel (2.4360) - TMC/TMD	316/316L (1.4401/1.4404) Hastelloy C (2.4819)	316/316L (1.4401/1.4404)
Sanitary finish	0.82 µm (RA 32) – consult factory for electropolishing – only for TMA/TMB		
Sensor / pipe diameter	22,5 mm (0.875") – except TMM 16 mm (0.63") – TMM	22,5 mm (0.875")	1/4" or 1/2"
Process connection	Threaded: 1/2" NPT (TMM), 3/4" NPT, 1" NPT, G1 (1" BSP) Flanged: ANSI, EN/DIN or sanitary		F- 1/4" or 1/2" NPT or BSP
Probe length	5 - 330 cm (2" - 130") 2,5 - 150 cm (1" - 60") – TMM	5 to 90 cm (2-36")	Not applicable
Max process temperature ^①	TMA/TMC/TMM: -70 to +120 °C (-100 to 250 °F) TMB/TMD: -70 to +200 °C (-100 to 390 °F)	-70 °C to +450 °C (-100 °F to +850 °F)	-70 °C to +120 °C (-100 °F to +250 °F)
Max process pressure	TMA/TMB: 41 bar (600 psi) TMC/TMD: 207 bar (3000 psi) ^② TMM: 207 bar (3000 psi) ^②	413 bar (6000 psi)	400 bar (5800 psi)
Recommended for	TMA: best sensitivity for liquid flows / suitable for gas flow – resists heavy coating TMB: same as TMA but can be used with integral electronics up to +200 °C (+400 °F) TMC: best sensitivity for air/gas flows – resists light coating TMD: same as TMC but can be used with integral electronics up to 200 °C (+400 °F) TMM: for direct mounting in "T" pieces on small pipe sizes – light coating TMH: high temperature and pressure conditions – light coating TML: for the detection, control of extreme low flows, resists light coating		

^① Use remote electronics (TD2) for temperatures > +120 °C (+250 °F) up to max +200 °C (+400 °F) or sensors with heat extension (TMB/TMD) when using integral electronics.

^② Max. 127 bar (1850 psig) for sensors > min. length.

IDENTIFICATION - ELECTRONICS

T D 1	Thermatel TD1 Electronics
T D 2	Thermatel TD2 Electronics with continuous LED indication and mA output

POWER

2	24 V DC – TD1
7	240 V AC (100-264 V AC) – TD2
8	24 V DC (± 20 %) – TD2

OUTPUT

D 0	8 A DPDT relay
H 0	1 A Hermetically sealed DPDT relay ^① – TD2

^① requires for ATEX 1G / zone 0 applications a TMC/TMD/TMH sensor with 1 mm wall thickness

ACCESSORIES

0	Blind housing cover
1	Housing cover with glass window (for aluminium housings only) – TD2

MOUNTING CONFIGURATION

0	Integral electronics
1	Remote electronics – TD2

APPROVALS

3	General purpose / FM-CSA explosion proof
C	ATEX explosion proof – zone 0 for TD2 / zone 0 and 1 for TD1
G	ATEX explosion proof – zone 1 for TD2

HOUSING - INDUSTRIAL

0	IP66, Cast Aluminium housing, 3/4" NPT cable entry (2 entries - one plugged)
1	IP66, Cast Aluminium housing, M20 x 1,5 cable entry (2 entries - one plugged)
2	IP66, Cast 316 SST housing, 3/4" NPT cable entry (2 entries - one plugged)
3	IP66, Cast 316 SST housing, M20 x 1,5 cable entry (2 entries - one plugged)

HOUSING - HYGIENIC

4	IP67, 304 SST housing, 1/2" NPT cable entry (2 entries - one plugged)
5	IP67, 304 SST housing, M20 x 1,5 cable entry (2 entries - one plugged)

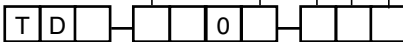

complete code for Thermatel® TD1/TD2 electronics

REPLACEMENT PARTS

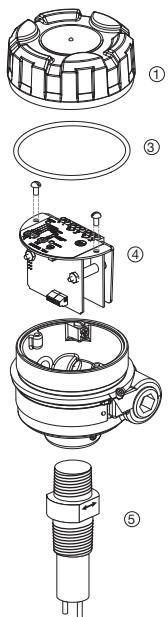

Item	Description	TD1	TD2 integral	TD2 remote	
1	Cover with window - cast aluminium	Not available	036-4410-010		
	Cover without window - cast aluminium	004-9193-003	004-9192-004		
	Cover with window - cast SST	Not available	Not available		
	Cover without window - cast SST	Not available	004-9192-023		
	Cover with window - Hygienic hsg	Not available	036-5702-002	Not available	
	Cover without window - Hygienic hsg	Not available	036-5702-003	Not available	
2	Remote sensor cover - cast aluminium	Not available	Not available	004-9193-003	
	Remote sensor cover - cast SST	Not available	Not available	004-9193-007	
3	Housing "O" ring Industrial	012-2201-237			
	Hygienic housing	Not available	012-2201-155	Not available	
4	Electronic module - Industrial hsg V DC / 8 A DPDT relay for zone 1 and G.P. for zone 0	089-7250-001 089-7250-001	089-7250-003 089-7250-011	089-7250-005 089-7250-013	
	V AC / 8 A DPDT relay for zone 1 and G.P. for zone 0	Not available Not available	089-7250-002 089-7250-010	089-7250-004 089-7250-012	
	V DC / 1 A HS DPDT relay	Not available	089-7250-007	089-7250-009	
	V AC / 1 A HS DPDT relay	Not available	089-7250-006	089-7250-008	
	Electronic module - Hygienic hsg V DC / 8 A DPDT relay	Not available	089-7253-002	Not available	
	V AC / 8 A DPDT relay	Not available	089-7253-001	Not available	
	V DC / 1 A HS DPDT relay	Not available	089-7253-004	Not available	
	V AC / 1 A HS DPDT relay	Not available	089-7253-003	Not available	
5	Probe	See probe Model number – sales bulletin 54-110			

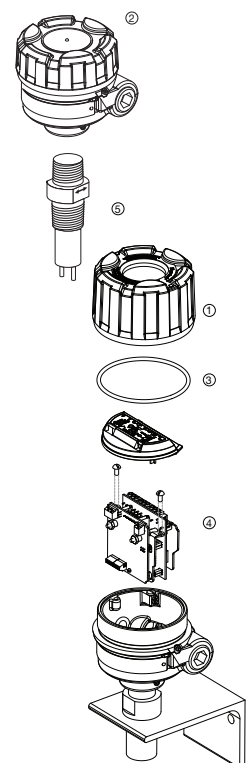

IDENTIFICATION - SENSOR (for ordering information, consult bulletin 54-110)

T M A	Standard spherical tip	max 120 °C (250 °F) / max 41 bar (600 psi)
T M B	Standard spherical tip - with heat extension	max 200 °C (400 °F) / max 41 bar (600 psi)
T M C	Standard twin tip	max 120 °C (250 °F) / max 207 bar (3000 psi) - 127 bar (1850 psi)
T M D	Standard twin tip - with heat extension	max 200 °C (400 °F) / max 207 bar (3000 psi) - 127 bar (1850 psi)
T M H	High temperature / high pressure twin tip	max 450 °C (850 °F) / max 413 bar (6000 psi)
T M M	Mini twin tip (16 mm diam.)	max 120 °C (250 °F) / max 207 bar (3000 psi) - 127 bar (1850 psi)
T M L	Low flow body	max 120 °C (250 °F) / max 400 bar (5800 psi)

MATERIAL OF CONSTRUCTION FOR SENSOR AND PROCESS CONNECTION

A	316/316 L (1.4401/1.4404) stainless steel
B	Hastelloy C (2.4819) – 1 mm wall thickness
C	Monel (2.4360) – 1 mm wall thickness
D	316/316 L (1.4401/1.4404) stainless steel – 1 mm wall thickness

PROCESS CONNECTION SIZE

Threaded

0 1	Threaded 1/2" NPT – TMM sensor only
1 1	Threaded 3/4" NPT
2 1	Threaded 1" NPT
2 2	Threaded G1 (1" BSP)
T 1	Threaded 1/4" NPT – TML sensor only
V 1	Threaded 1/2" NPT – TML sensor only
T 0	Threaded G 1/4 (1/4" BSP) – TML sensor only
V 0	Threaded G 1/2 (1/2" BSP) – TML sensor only

ANSI RF Flanged

2 3	1"	150 lbs ANSI RF flange
2 4	1"	300 lbs ANSI RF flange
2 5	1"	600 lbs ANSI RF flange
2 7	1"	900/1500 lbs ANSI RF flange
3 3	1 1/2"	150 lbs ANSI RF flange
3 4	1 1/2"	300 lbs ANSI RF flange
3 5	1 1/2"	600 lbs ANSI RF flange
3 7	1 1/2"	900/1500 lbs ANSI RF flange
3 8	1 1/2"	2500 lbs ANSI RF flange
4 3	2"	150 lbs ANSI RF flange
4 4	2"	300 lbs ANSI RF flange
4 5	2"	600 lbs ANSI RF flange
4 7	2"	900/1500 lbs ANSI RF flange
4 8	2"	2500 lbs ANSI RF flange

EN/DIN Flanged

B A	DN 25 PN 16	EN 1092, Type A
B B	DN 25 PN 25/40	EN 1092, Type A
B C	DN 25 PN 63/100	EN 1092, Type B2
B G	DN 25 PN 250	EN 1092, Type B2
C A	DN 40 PN 16	EN 1092, Type A
C B	DN 40 PN 25/40	EN 1092, Type A
C C	DN 40 PN 63/100	EN 1092, Type B2
C G	DN 40 PN 250	EN 1092, Type B2
C J	DN 40 PN 400	EN 1092, Type B2
D A	DN 50 PN 16	EN 1092, Type A
D B	DN 50 PN 25/40	EN 1092, Type A
D D	DN 50 PN 63	EN 1092, Type B2
D E	DN 50 PN 100	EN 1092, Type B2
D G	DN 50 PN 250	EN 1092, Type B2
D J	DN 50 PN 400	EN 1092, Type B2

Sanitary Flanged

3 T	1" and 1 1/2"	3A compatible
4 T	2"	3A compatible
B S	DIN 11.851	DN 25
C S	DIN 11.851	DN 40
D S	DIN 11.851	DN 50

V V	Varivent	DN 65
B N	NEUMO Bio Control®	D 25
D N	NEUMO Bio Control®	D 50
V N	NEUMO Bio Control®	D 65

INSERTION LENGTH IN INCREMENTS OF 10 mm (0.39")

0 0 3	Min. 25,4 mm (1")
3 3 0	Max. 3300 mm (130")
0 0 0	No mounting bracket – low flow body sensor
1 0 0	Mounting bracket – low flow body sensor in carbon steel



SENSORS - DIMENSIONS IN MM (INCHES) / TEMP.-PRESSURE RATING

NOTE: Flanged models are downrated to the design pressure of the selected flange.

Spherical sensor (TMA/TMB)

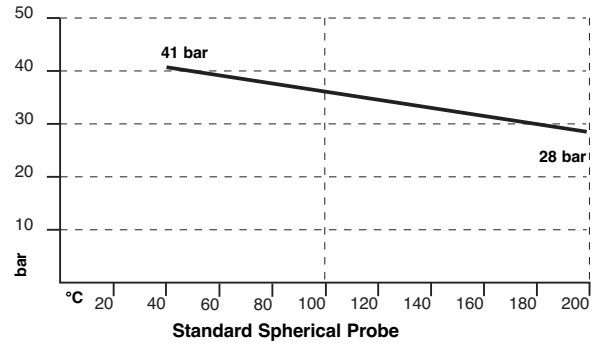
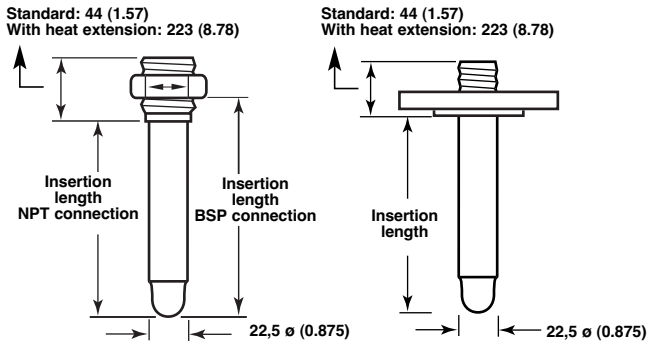

Twin tip sensor (TMC/TMD)

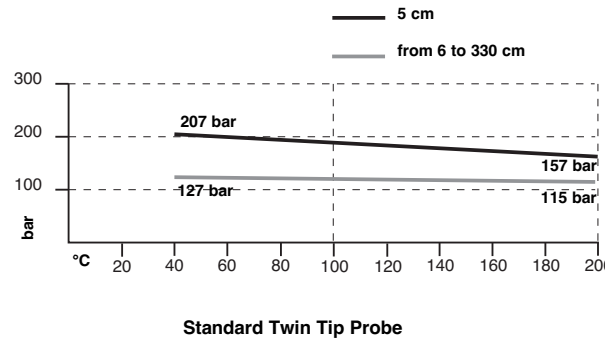
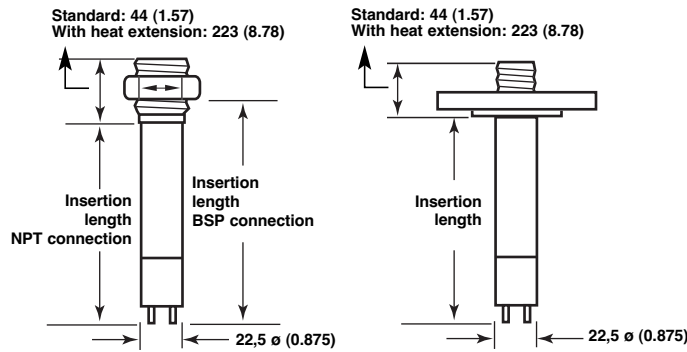

Mini sensor (TMM)

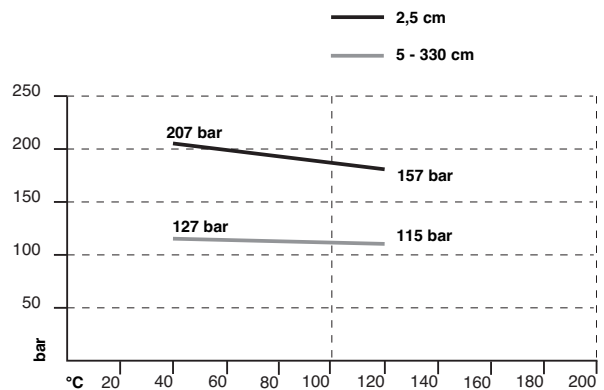
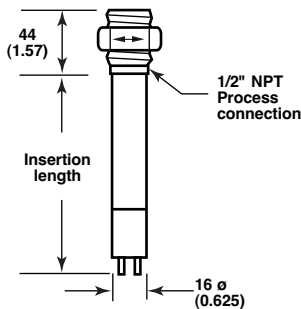

Low flow body sensors (TML)

Max 285 bar (4100 psi) @ max +120 °C (+250 °F) – integral electronics
 Max 285 bar (4100 psi) @ max +200 °C (+250 °F) – remote electronics
 Max 400 bar (5800 psi) @ max +40 °C (+100 °F)

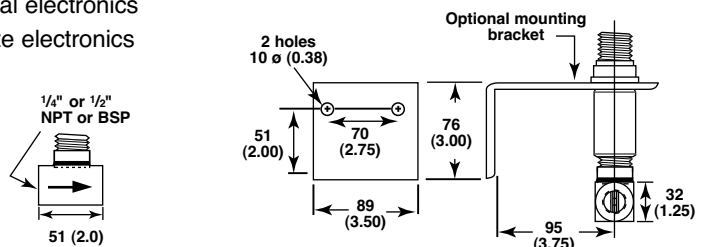

SENSORS - DIMENSIONS IN MM (INCHES) / TEMP.-PRESSURE RATING

High temp/pressure sensor (TMH)

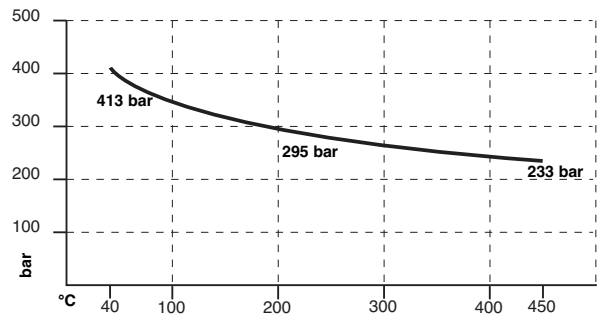
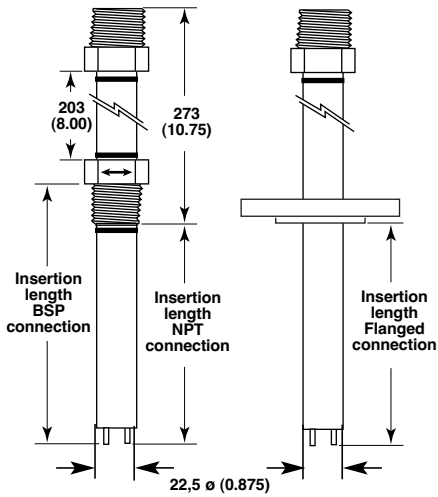

ELECTRONICS - DIMENSIONS IN MM (INCHES)

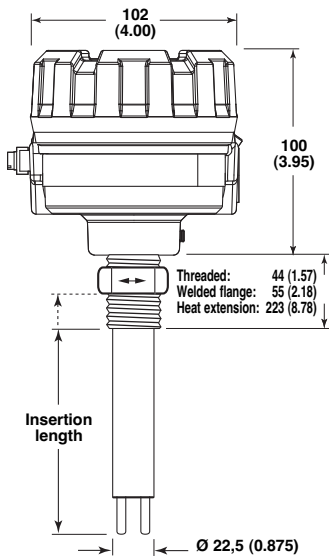

Model TD1 with Twin Tip Sensor

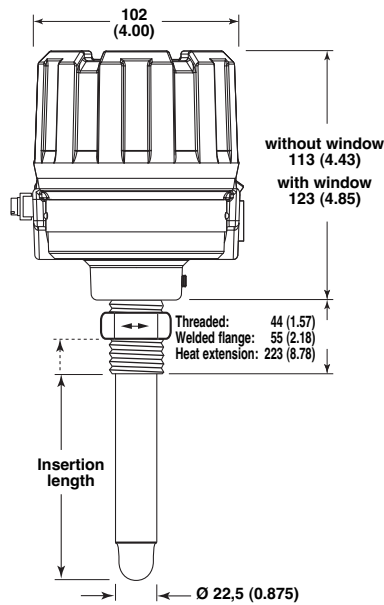

Model TD2
Integral electronics with Spherical Tip
Sensor

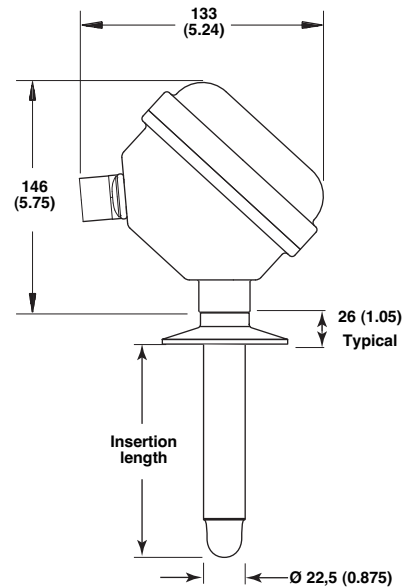

Model TD2
Integral electronics
with TMC Spherical Tip Sensor

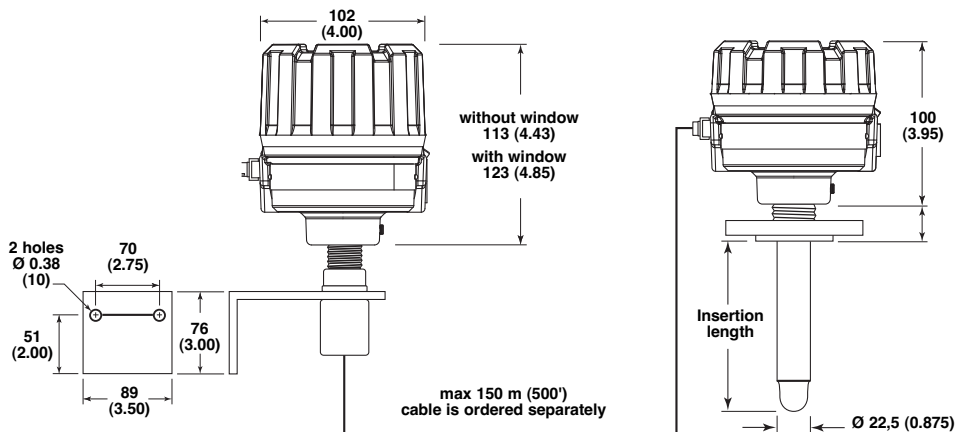

Model TD2 with Remote electronics

Remote Spherical Tip Probe
with Flange Connection

IMPORTANT

SERVICE POLICY

Owners of Magnetrol products may request the return of a control; or, any part of a control for complete rebuilding or replacement. They will be rebuilt or replaced promptly. Magnetrol International will repair or replace the control, at no cost to the purchaser, (or owner) **other than transportation cost** if:

- a. Returned within the warranty period; and,
- b. The factory inspection finds the cause of the malfunction to be defective material or workmanship.

If the trouble is the result of conditions beyond our control; or, is **NOT** covered by the warranty, there will be charges for labour and the parts required to rebuild or replace the equipment.

In some cases, it may be expedient to ship replacement parts; or, in extreme cases a complete new control, to replace the original equipment before it is returned. If this is desired, notify the factory of both the model and serial numbers of the control to be replaced. In such cases, credit for the materials returned, will be determined on the basis of the applicability of our warranty.

No claims for misapplication, labour, direct or consequential damage will be allowed.

RETURNED MATERIAL PROCEDURE

So that we may efficiently process any materials that are returned, it is essential that a "Return Material Authorisation" (RMA) form will be obtained from the factory. It is mandatory that this form will be attached to each material returned. This form is available through Magnetrol's local representative or by contacting the factory. Please supply the following information:

1. Purchaser Name
2. Description of Material
3. Serial Number and Ref Number
4. Desired Action
5. Reason for Return
6. Process details

All shipments returned to the factory must be by prepaid transportation. Magnetrol **will not accept** collect shipments. All replacements will be shipped FOB factory.

BULLETIN N°: BE 54-610.2
EFFECTIVE: MARCH 2008
SUPERSEDES: April 2007

UNDER RESERVE OF MODIFICATIONS



www.magnetrol.com

BENELUX FRANCE	Heikensstraat 6, 9240 Zele, België - Belgique Tél. +32 (0)52.45.11.11 • Fax. +32 (0)52.45.09.93 • E-Mail: info@magnetrol.eu
DEUTSCHLAND	Alte Ziegelei 2-4, D-51491 Overath Tel. +49 (0)2204 / 9536-0 • Fax. +49 (0)2204 / 9536-53 • E-Mail: vertrieb@magnetrol.de
INDIA	C-20 Community Centre, Janakpuri, New Delhi - 110 0058 Tel. +91 (11) 41661840 • Fax +91 (11) 41661843 • E-Mail: info@magnetrolindia.com
ITALIA	Via Arese 12, I-20159 Milano Tel. +39 02 607.22.98 (R.A.) • Fax. +39 02 668.66.52 • E-Mail: mit.gen@magnetrol.it
U.A.E.	DAFZA Office 5EA 722 • PO Box 293671 • Dubai Tel. +971-4-6091735 • Fax +971-4-6091736 • E-Mail: info@magnetrol.ae
UNITED KINGDOM	Unit 1 Regent Business Centre, Jubilee Road Burgess Hill West Sussex RH 15 9TL Tel. +44 (0)1444 871313 • Fax +44 (0)1444 871317 • E-Mail: sales@magnetrol.co.uk